

AM/FM IF SYSTEM IC

The KIA6040P is AM/FM IF system IC designed for portable use. As compared with conventional IC, this IC is greatly improved in external parts counts and electrical characteristics, especially tweet and overload distortion.

FEATURES

- Low Supply Current, AM:7mA, FM : 10mA(Typ.).
- Few External Parts.
- Excellent Tweet.
- Low Overload Distortion.
- Tuning Indicator LED Driving Capability : $I_{LAMP}=10mA$ (Typ.)
- Built-in AM/FM Mode Switch.
- Common Output for AM/FM.
- Operating Supply Voltage Range : $V_{CC(opr)}=3 \sim 8V$ ($T_a=25^\circ C$).

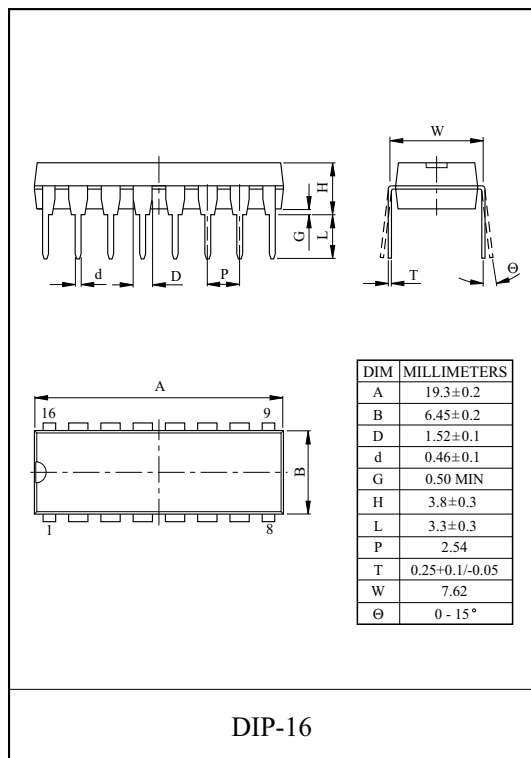

MAXIMUM RATINGS ($T_a=25^\circ C$)

CHARACTERISTIC	SYMBOL	RATING	UNIT
Supply Voltage	V_{CC}	8	V
Lamp Current	I_{LAMP}	10	mA
Power Dissipation (Note)	P_D	750	mW
Operating Temperature	T_{opr}	-25 ~ 75	°C
Storage Temperature	T_{stg}	-55 ~ 150	°C

Note : Derated above $T_a=25^\circ C$ in the Proportion of 6mW/°C for KIA6040P.

KIA6040P

BLOCK DIAGRAM

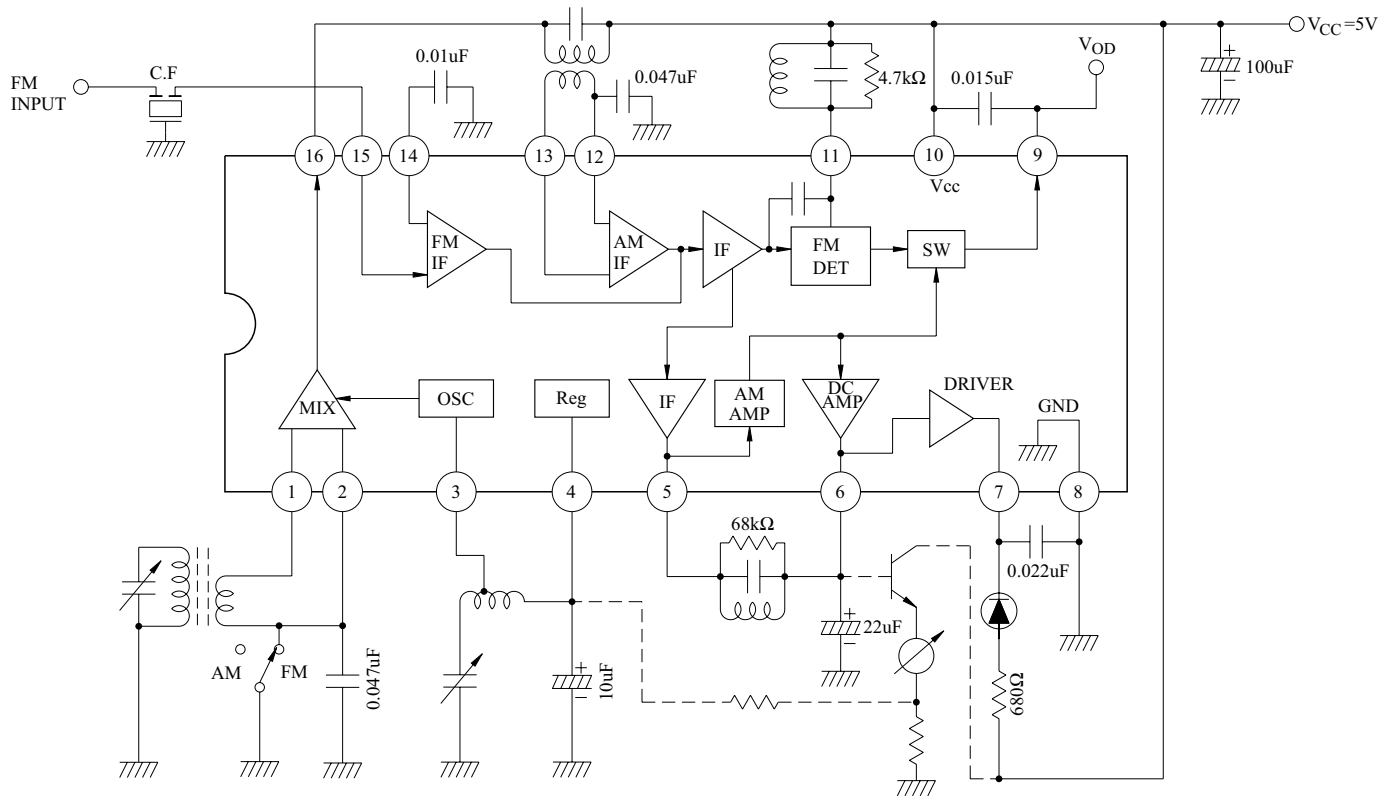

Note : The dot line denotes a tuning meter application.

ELECTRICAL CHARACTERISTICS

1. DC CHARACTERISTICS ($V_{CC}=5V$, Terminal voltage at no signal)

PIN NO.	ITEM	SYMBOL	Typ.		UNIT
			AM	FM	
1	(AM MIX IN)	V_1	1.5	0	V
2	(AM MIX BYPASS)	V_2	1.5	0	V
3	(AM OSC)	V_3	2.3	2.3	V
4	(Reg)	V_4	2.3	2.3	V
5	(AM IF OUT)	V_5	1.0	0.9	V
6	(Meter OUT)	V_6	1.0	0.9	V
7	(LED)	V_7	-	-	V
8	(GND)	V_8	0	0	V
9	(DET OUT)	V_{19}	1.4	1.5	V
10	(V_{CC})	V_{10}	5.0	5.0	V
11	(FM DET)	V_{11}	5.0	5.0	V
12	(AM IF BYPASS)	V_{12}	1.5	1.5	V
13	(AM IF IN)	V_{13}	1.5	1.5	V
14	(FM IF BYPASS)	V_{14}	1.5	1.5	V
15	(FM IF IN)	V_{15}	1.5	1.5	V
16	(AM MIX OUT)	V_{16}	5.0	5.0	V

KIA6040P

2. AC CHARACTERISTICS

(Ta=25 °C, Vcc=5V, FM : f=10.7kHz, $\Delta f = \pm 22.5\text{kHz dev.}$, fm=400Hz

AM : f=1MHz, Mod=30%, fm=400Hz)

CHARACTERISTIC		SYMBOL	TEST CIRCUIT	TEST CONDITION	MIN.	TYP.	MAX.	UNIT
Supply Current		I _{CC(1)}	1	FM V _{IN} =0	-	10	15	mA
		I _{CC(2)}		AM V _{IN} =0	-	7	10	
FM	Input Limiting Voltage	V _{IN(lim)}	1	-3dB Limiting	-	40	46	dB μ
	Recovered Output Voltage	V _{OD}	1	V _{IN} =66dB μ	57	85	114	mV _{rms}
	Signal to Noise Ratio	S/N	1	V _{IN} =80dB μ	-	65	-	dB μ
	Total Harmonic Distortion	THD	1	V _{IN} =80dB μ	-	0.05	-	%
	AM Rejection Ratio	AMR	1	V _{IN} =80dB μ	-	38	-	dB μ
	Meter Drive Voltage	V _M	1	V _{IN} =100dB μ	1.6	1.75	1.9	V
	Lamp ON Sensitivity	V _L	1	I _L =1mA	-	46	52	dB
AM	Gain	G _V	1	V _{IN} =26dB μ	20	30	60	mV _{rms}
	Recovered Output Voltage	V _{OD}	1	V _{IN} =60dB μ	65	95	125	mV _{rms}
	Signal to Noise Ratio	S/N	1	V _{IN} =60dB μ	-	47	-	dB
	Total Harmonic Distortion	THD	1	V _{IN} =60dB μ	-	1.0	-	%
	Meter Drive Voltage	V _M	1	V _{IN} =100dB μ	1.6	1.75	1.9	V
	Lamp ON Sensitivity	V _L	1	I _L =1mA	-	32	-	dB μ
	Local OSC Stop Voltage	V _{stop}	1	R _{DUMP} = ∞	-	1.5	-	V
Pin ⑨ Output Resistance		R ₀₉	-	f=1kHz	-	3.0	-	k Ω

KIA6040P

TEST CIRCUIT

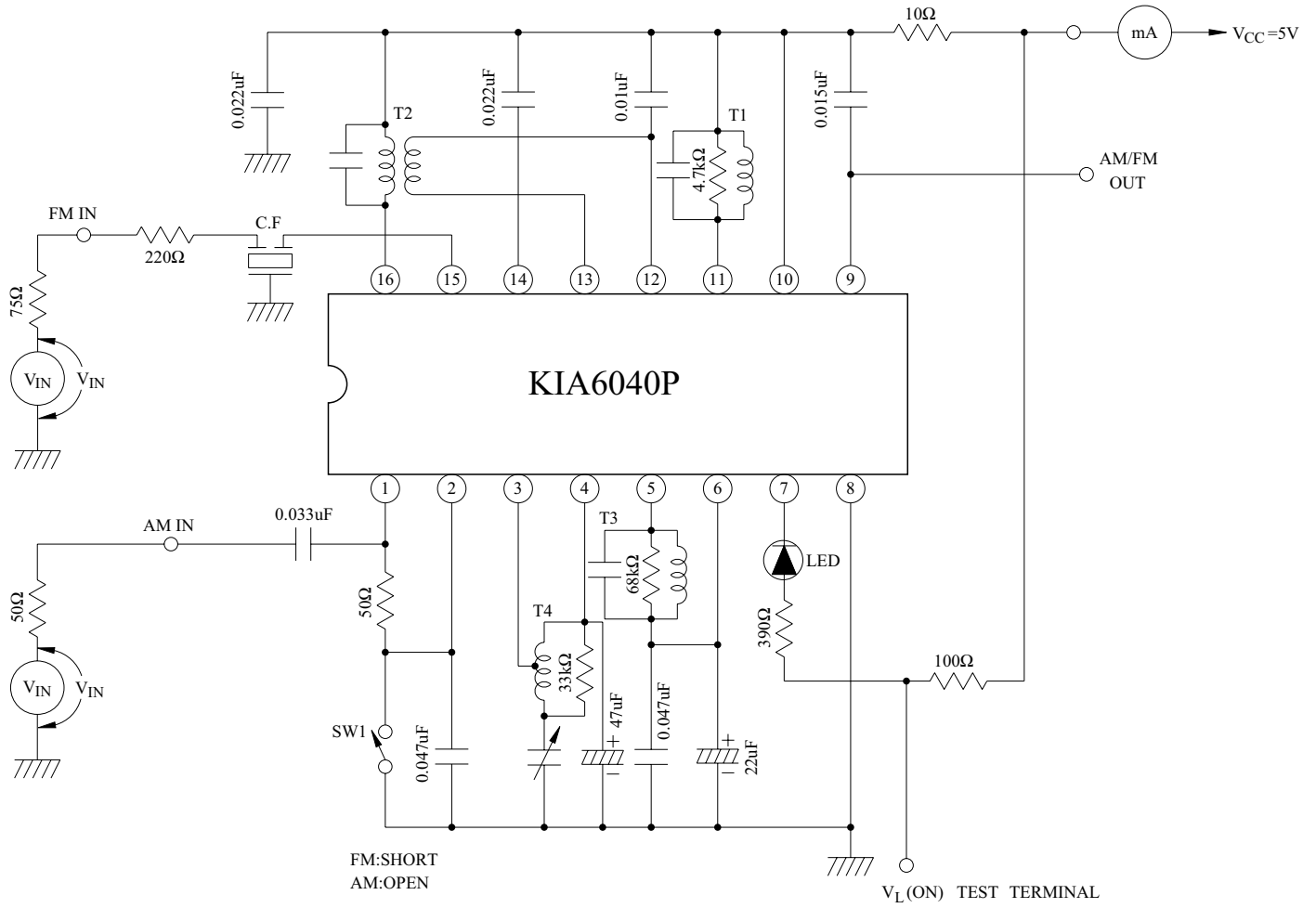

KIA6040P

COIL DATA (TEST CIRCUIT)

T₁ FM DETECTOR COIL

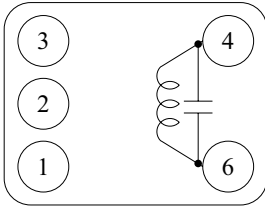

(BOTTOM VIEW)

C ₀ (pF)	f (MHz)	Q ₀	TURNS
4-6		4-6	4-6
47	10.7	150	14

Ⓚ : KSC0902
 Ⓢ : 44M-933A or
 SIMILAR
 WIRE : 0.12mmφUEW

T₂ AM IFT (MIX OUT)

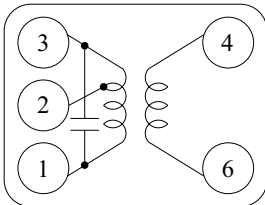

(BOTTOM VIEW)

C ₀ (pF)	f (MHz)	Q ₀	TURNS		
1-3		4-6	1-2	2-3	4-6
180	455	150	90	62	8

Ⓚ : KS M308
 Ⓢ : 48T-423 or
 SIMILAR
 WIRE : 0.07mmφUEW

T₃ AM IFT (DET)

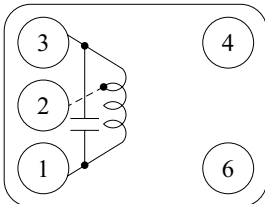

(BOTTOM VIEW)

C ₀ (pF)	f (MHz)	Q ₀	TURNS
1-3		1-3	1-
180	455	110	152

Ⓚ : KSAD106
 Ⓢ : 44M-935C or
 SIMILAR
 WIRE : 0.07mmφUEW

T₄ MW OSC

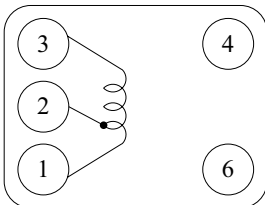

(BOTTOM VIEW)

f (kHz)	L(μH)	Q ₀	TURNS	
	1-3	1-3	1-2	2-3
796	288	120	13	75

Ⓚ : KSA0408
 Ⓢ : 0137-262 or
 SIMILAR
 WIRE : 0.08mmφUEW

NOTE : Ⓚ : KWANG SUNG ELECTRIC CO., LTD.

(Tel : 02)716-0034

Ⓢ : SUMIDA ELECTRIC CO., LTD.

KIA6040P

APPLICATION CIRCUIT

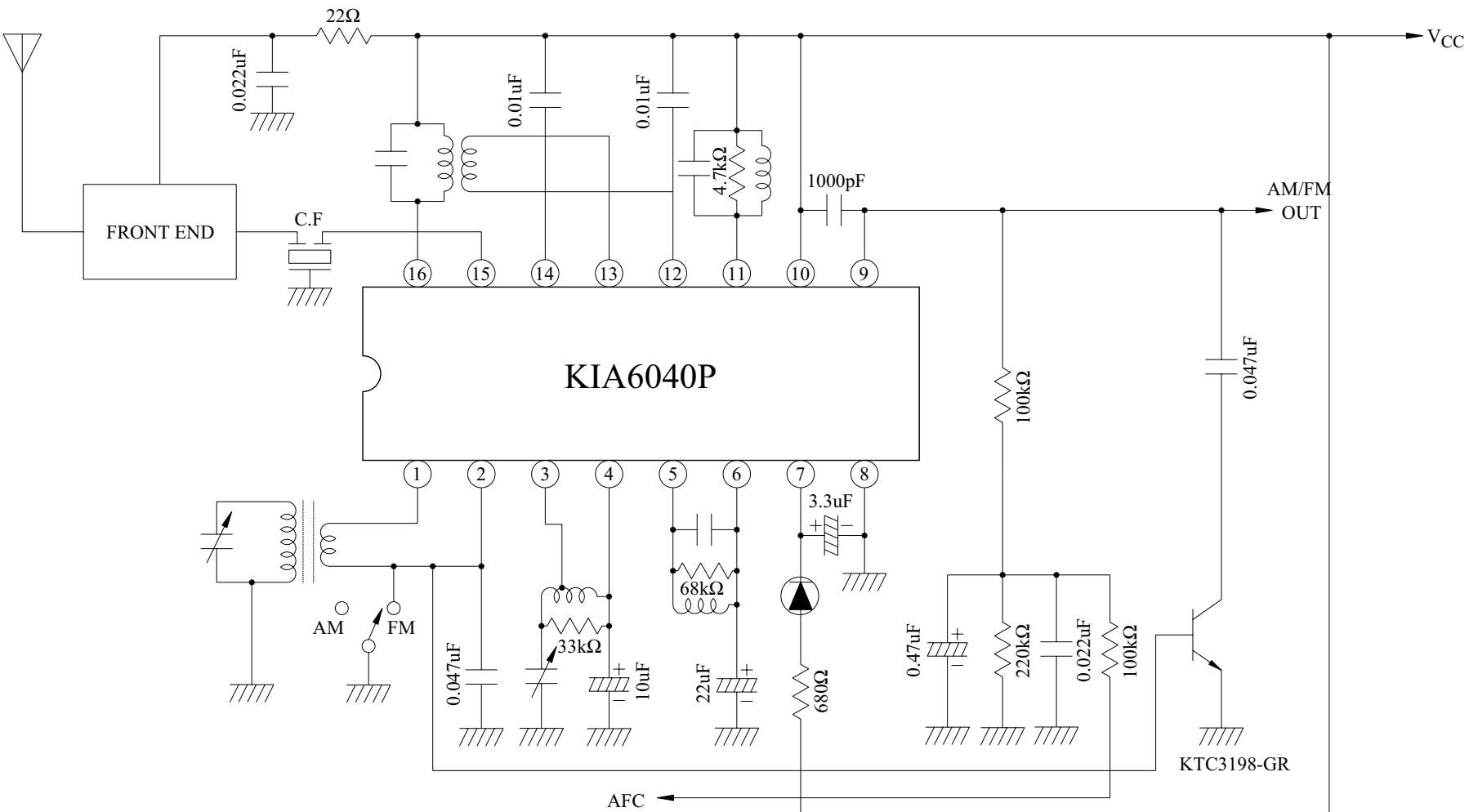

KIA6040P

FM V_{OD} , AMR, S/N, THD, $V_M - V_{IN}$

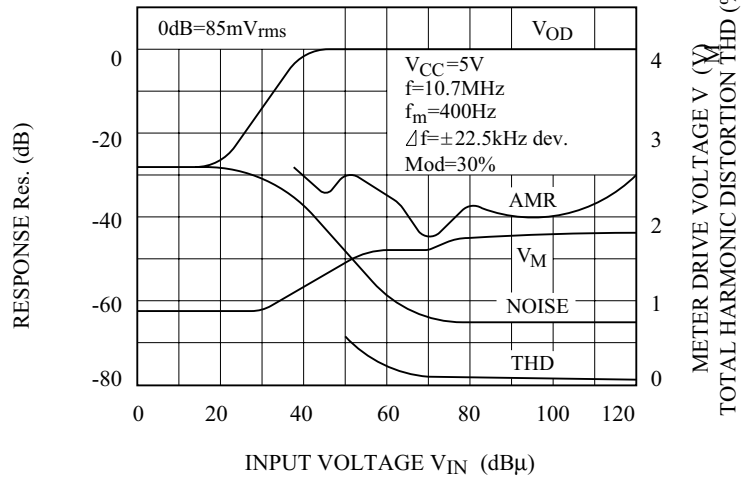

FM V_{OD} , V_{IN} (lim), V_L , $V_M - T_a$

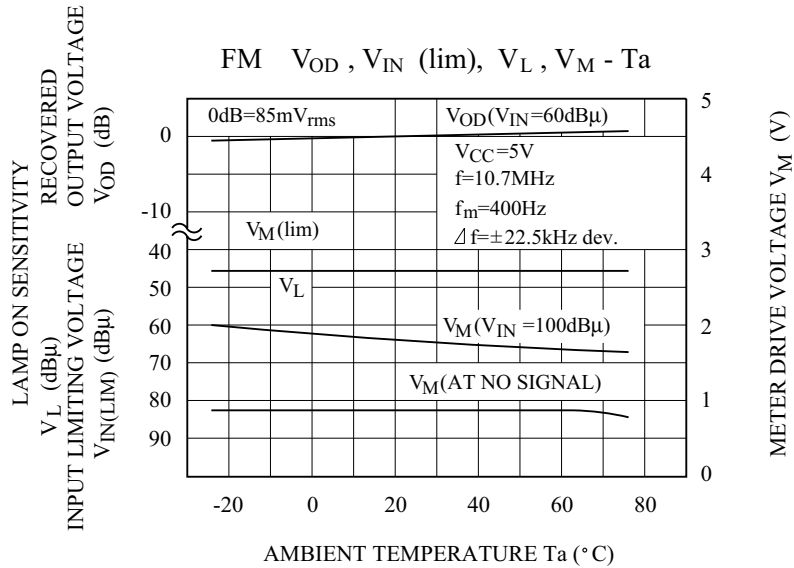

AM V_{OD} , S/N, THD, $V_M - V_{IN}$

