

## VERTICAL DEFLECTION CIRCUIT

- RAMP GENERATOR
- INDEPENDENT AMPLITUDE ADJUSTEMENT
- BUFFER STAGE
- POWER AMPLIFIER
- FLYBACK GENERATOR
- INTERNAL REFERENCE VOLTAGE
- THERMAL PROTECTION

### DESCRIPTION

The TDA1771 is a monolithic integrated circuit in SIP10 package.

It is a full performance and very efficient vertical deflection circuit intended for direct drive of a TV picture tube in Color and B & W television as well as in Monitor and Data displays.

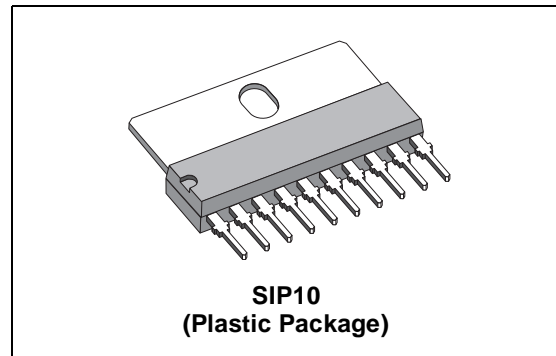

**Figure 1. PIN CONNECTIONS (Top View)**

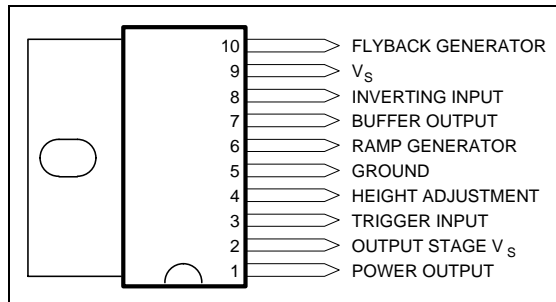

**Figure 2. BLOCK DIAGRAM**

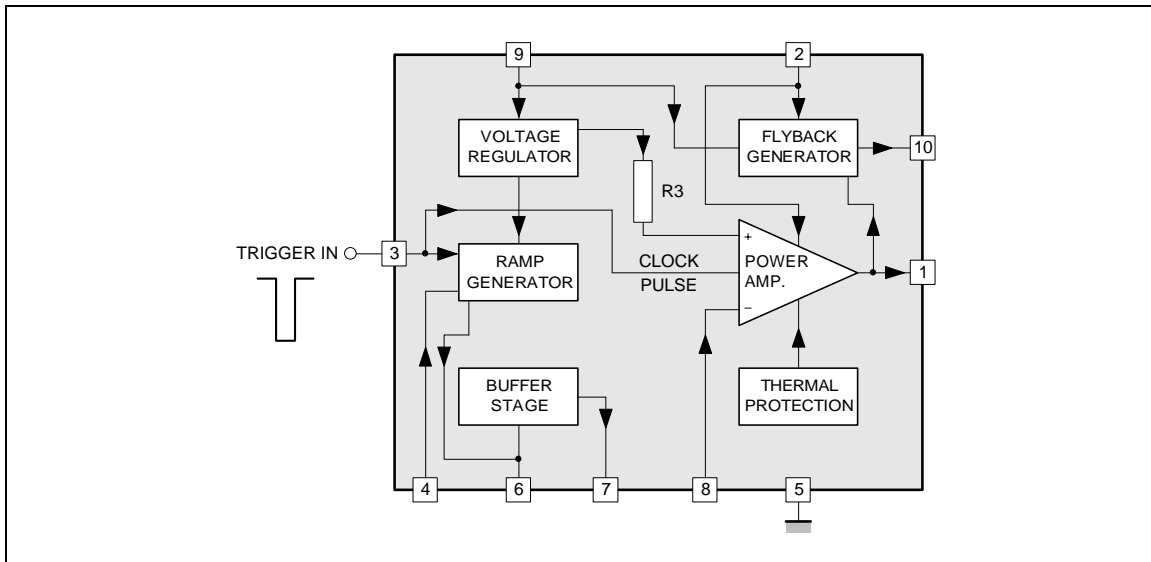

# TDA1771

## ABSOLUTE MAXIMUM RATINGS

Symbol	Parameter	Value	Unit
$V_S$	Supply Voltage	30	V
$V_1, V_2$	Flyback Peak Voltage	65	V
$V_3$	Trigger Input Voltage	20	V
$V_8$	Amplifier Input Voltage	GNDto $V_S$	V
$I_0$	Output Peak to Peak Current (non repetitive t = 2ms)	6	A
$I_0$	Output Peak to Peak Current t > 10 $\mu$ s	4	A
$I_{10}$	Pin 10 DC Current at $V_1 < V_9$	100	mA
$I_{10}$	Pin 10 Peak to Peak Current @ $t_{fly} < 1.5$ ms	3	A
$P_{tot}$	Total Power Dissipation @ $T_{tab} = 60^\circ\text{C}$	9	W
$T_S, T_J$	Storage and Junction Temperature	- 40, + 150	$^\circ\text{C}$

## THERMAL DATA

Symbol	Parameter+	Value	Unit
$R_{th(j-tab)}$	Thermal Resistance Junction-tab Max.	10	$^\circ\text{C/W}$
$R_{th(j-a)}$	Thermal Resistance Junction-ambient Max.	70	$^\circ\text{C/W}$

## ELECTRICAL CHARACTERISTICS ( $T_{amb} = 25^\circ\text{C}$ unless otherwise specified)

Symbol	Parameter	TestConditions	Min.	Typ.	Max.	Unit
DC( $V_S=30\text{V}$ )						
$I_2$	Pin 2 Quiescent Current	$I_1 = 0, I_{10} = 0$		16	36	mA
$I_9$	Pin 9 Quiescent Current	$I_1 = 0, I_{10} = 0$		15	30	mA
$-I_6$	Ramp Generator Bias Current	$V_6 = 0$			0.5	$\mu\text{A}$
$-I_6$	Ramp Generator Current	$V_6 = 0, -I_4 = 20\mu\text{A}$	18.5	20	21.5	$\mu\text{A}$
$dI_6/I_6$	Ramp Gener. Linearity	$V_6 = 0$ to 15V, $-I_4 = 20\mu\text{A}$		0.2	1	%
$V_1$	Quiescent Output Voltage	$R_a = 30\text{k}\Omega, R_b = 10\text{k}\Omega, V_S = 30\text{V}$	17.0	17.8	18.6	V
		$R_a = 6.8\text{k}\Omega, R_b = 10\text{k}\Omega, V_S = 15\text{V}$	7.2	7.5	7.8	V
$V_{1L}$	Out Saturation Voltage to GND	$I_1 = 0.5\text{A}$		0.5	1	V
		$I_1 = 1.2\text{A}$		1	1.4	V
$V_{1H}$	Out Saturation Voltage to $V_S$	$-I_1 = 0.5\text{A}$		1.1	1.6	V
		$-I_1 = 1.2\text{A}$		1.6	2.2	V
$V_4$	Reference Voltage	$-I_4 = 20\mu\text{A}$	6.3	6.6	6.9	V
$dV_4/V_S$	Reference Voltage Drift Versus $V_S$	$V_S = 10\text{V}$ to 30V		1	2	mV/V
$dV_4/dI_4$	Reference Voltage Drift Versus $I_4$	$I_4 = 10\mu\text{A}$ to 30 $\mu\text{A}$		1.5	2	mV/ $\mu\text{A}$
$V_r$	Internal Ref. Voltage		4.26	4.40	4.54	V
$G_v$	Output Stage Open Loop Gain	f = 100Hz		60		dB
$V_{fs}$	$V_9 - 10$ Saturation Voltage	$-I_{10} = 1.2\text{A}$		1.5	2.5	V
$V_{10}$	Pin 10 Scanning Voltage	$I_{10} = 20\text{mA}$		1.7	3	V
$V_3$	Trigger Input Threshold	(see note 1)	2.6	3.0	3.4	V
$I_3$	Trigger Input Bias Current	$V_{IN} = V_3 - 0.2\text{V}$			30	$\mu\text{A}$
$t_3$	Trigger Input Width	(see note 2)	20	60	th	$\mu\text{S}$

### Notes:

- The trigger input circuit can accept, with a metal option, positive and negative going pulses.
- $t_3 = \frac{1.2 \cdot t_S}{V_{PP}}$  where  $t_{Sis}$  is the vertical period and  $V_{PP}$  is ramp amplitude at Pin 6.

**ELECTRICAL CHARACTERISTICS ( $T_{amb} = 25^{\circ}\text{C}$  unless otherwise specified)**

Symbol	Parameter	Test Conditions	Min.	Typ.	Max.	Unit
DC ( $V_S = 24\text{V}$ )						
$V_S$	Operating Supply Voltage Range		10		30	V
$I_1$	Peak-to-peak Operating Current Range		0.4		2.5	A
$I_S$	Supply Current	$I_Y = 2.4\text{A}_{pp}$		315		mA
$V_1$	Flyback Voltage	$I_Y = 2.4\text{A}_{pp}$		51		V
$V_7$	Sawtooth Pedestall Voltage			1.85		V
$T_{JS}$	Junction Temp. for Thermal Shutdown			145		$^{\circ}\text{C}$

**APPLICATION CIRCUIT**

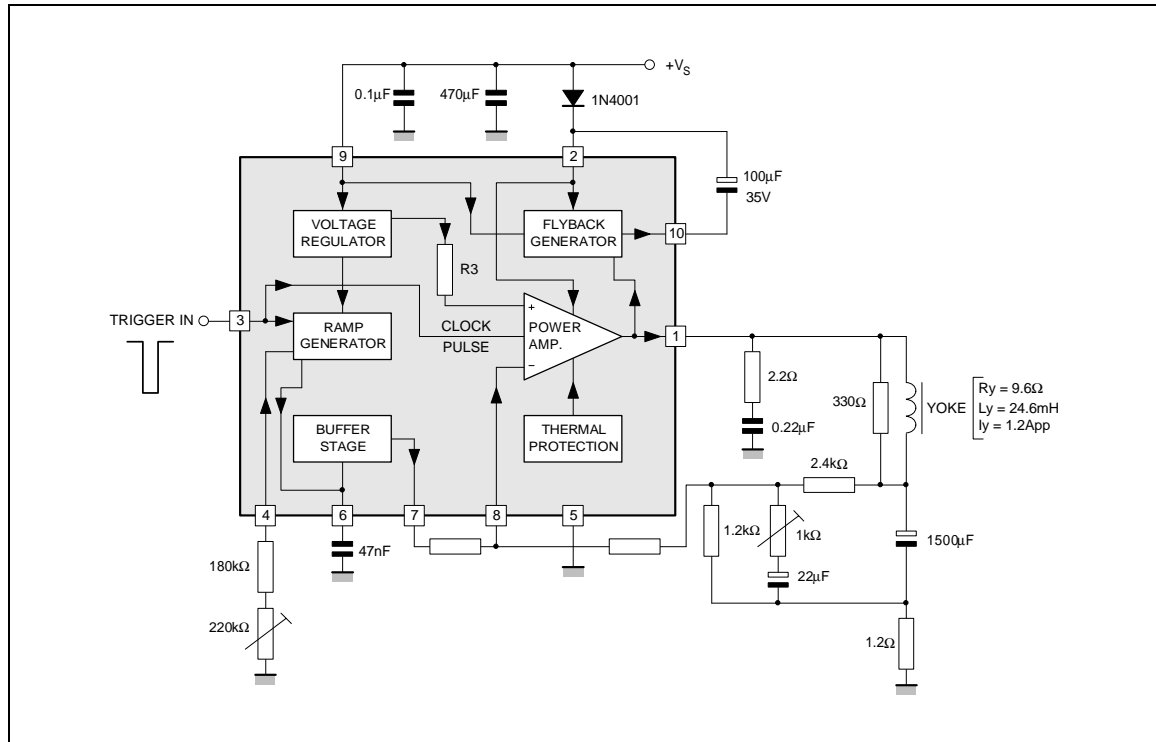

# TDA1771

## PACKAGE MECHANICAL DATA

10 PINS - PLASTIC SIP

Figure 3. 10-Pin Plastic Single in Line Package

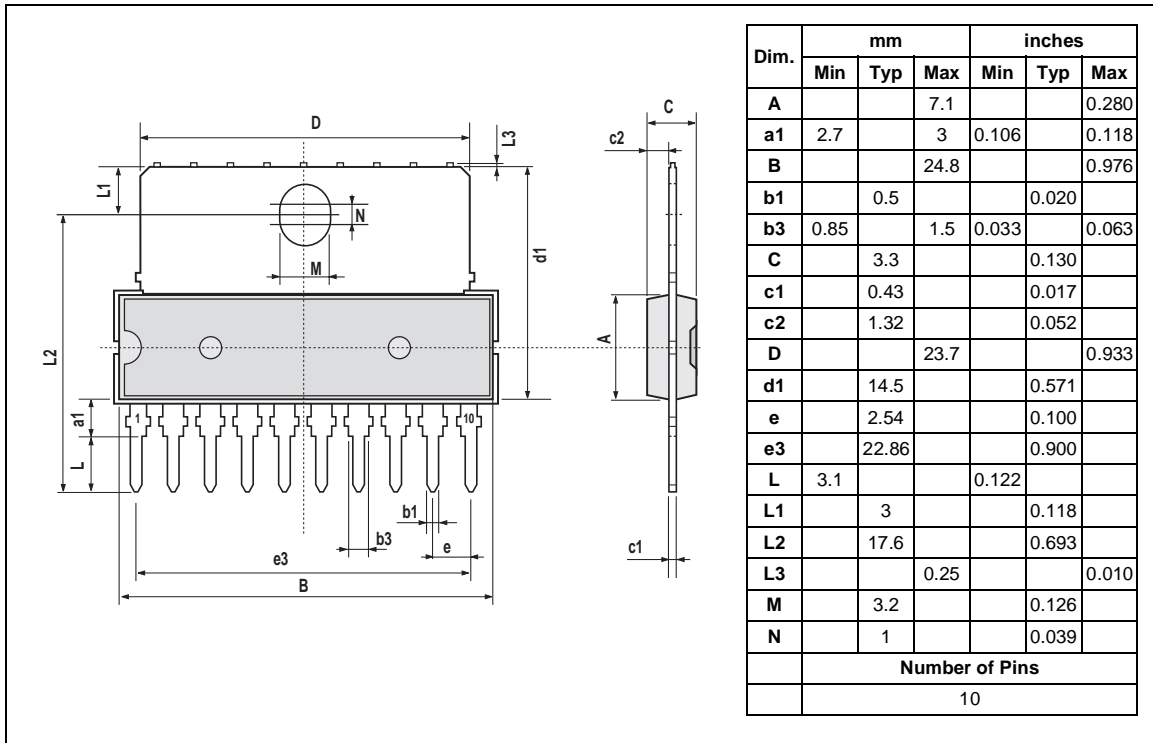

Information furnished is believed to be accurate and reliable. However, STMicroelectronics assumes no responsibility for the consequences of use of such information nor for any infringement of patents or other rights of third parties which may result from its use. No license is granted by implication or otherwise under any patent or patent rights of STMicroelectronics. Specifications mentioned in this publication are subject to change without notice. This publication supersedes and replaces all information previously supplied. STMicroelectronics products are not authorized for use as critical components in life support devices or systems without the express written approval of STMicroelectronics.

The ST logo is a registered trademark of STMicroelectronics

©2003 STMicroelectronics - All Rights Reserved.

Purchase of I<sup>2</sup>C Components by STMicroelectronics conveys a license under the Philips I<sup>2</sup>C Patent. Rights to use these components in an I<sup>2</sup>C system is granted provided that the system conforms to the I<sup>2</sup>C Standard Specification as defined by Philips.

STMicroelectronics Group of Companies

Australia - Brazil - China - Finland - France - Germany - Hong Kong - India - Italy - Japan - Malaysia - Malta - Morocco - Singapore - Spain  
Sweden - Switzerland - United Kingdom - U.S.A.

<http://www.st.com>