

Silicon NPN Power Transistors

2SC3549

DESCRIPTION

- With TO-220C package
- High voltage ,high speed switching
- High reliability

APPLICATIONS

- Switching regulators
- DC-DC convertor
- Solids state relay
- General purpose power amplifiers

PINNING

PIN	DESCRIPTION
1	Base
2	Collector;connected to mounting base
3	Emitter

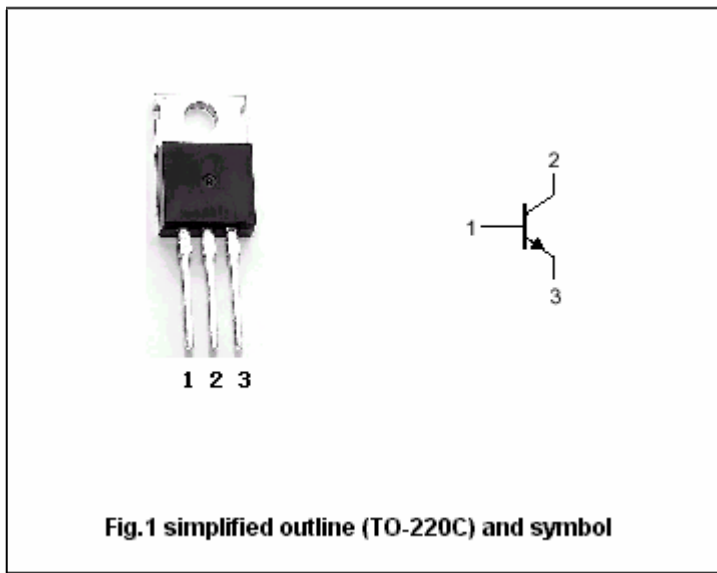

Absolute maximum ratings(Ta=25°C)

SYMBOL	PARAMETER	CONDITIONS	VALUE	UNIT
V _{CBO}	Collector-base voltage	Open emitter	900	V
V _{CEO}	Collector-emitter voltage	Open base	800	V
V _{EBO}	Emitter-base voltage	Open collector	10	V
I _C	Collector current		3	A
I _B	Base current		1	A
P _C	Collector power dissipation	T _C =25°C	40	W
T _j	Junction temperature		150	°C
T _{stg}	Storage temperature		-55~150	°C

THERMAL CHARACTERISTICS

SYMBOL	PARAMETER	MAX	UNIT
R _{th j-c}	Thermal resistance junction case	3.0	°C/W

Silicon NPN Power Transistors

2SC3549

CHARACTERISTICS

T_j=25 °C unless otherwise specified

SYMBOL	PARAMETER	CONDITIONS	MIN	TYP.	MAX	UNIT
V _{(BR)CEO}	Collector-emitter breakdown voltage	I _C =10mA ; I _B =0	800			V
V _{(BR)CBO}	Collector-base breakdown voltage	I _C =1mA ; I _E =0	900			V
V _{(BR)EBO}	Emitter-base breakdown voltage	I _E =1mA ; I _C =0	10			V
V _{CEsat}	Collector-emitter saturation voltage	I _C =1A; I _B =0.2A			1.0	V
V _{BEsat}	Base-emitter saturation voltage	I _C =1A; I _B =0.2A			1.5	V
I _{CBO}	Collector cut-off current	V _{CB} =900V ; I _E =0			1.0	mA
I _{EBO}	Emitter cut-off current	V _{EB} =10V; I _C =0			1.0	mA
h _{FE}	DC current gain	I _C =1 A ; V _{CE} =5V	10			

Switching times

t _{on}	Turn-on time	I _C =2A; I _{B1} =0.4A I _{B2} =-0.8A; R _L =150Ω			1.0	μs
t _s	Storage time				4.0	μs
t _f	Fall time				0.8	μs

Silicon NPN Power Transistors

2SC3549

PACKAGE OUTLINE

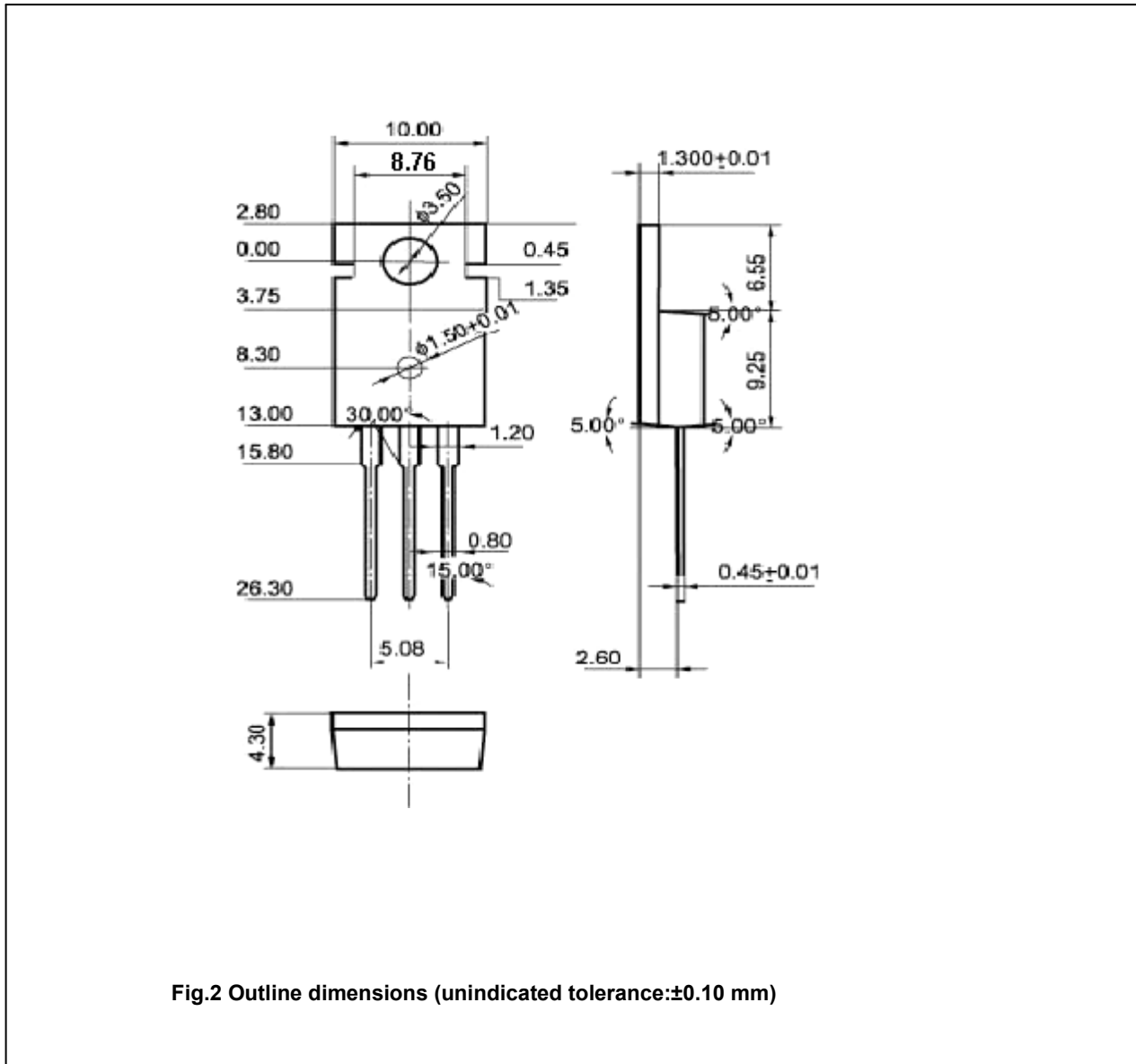

Silicon NPN Power Transistors

2SC3549

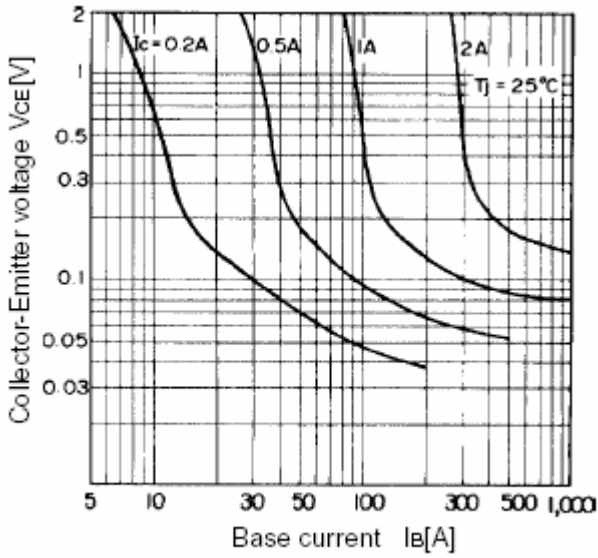

Fig.3 Static Characteristic

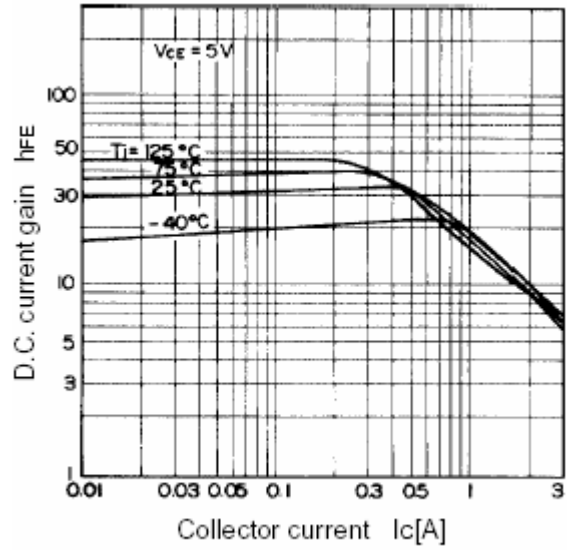

Fig.4 DC current Gain

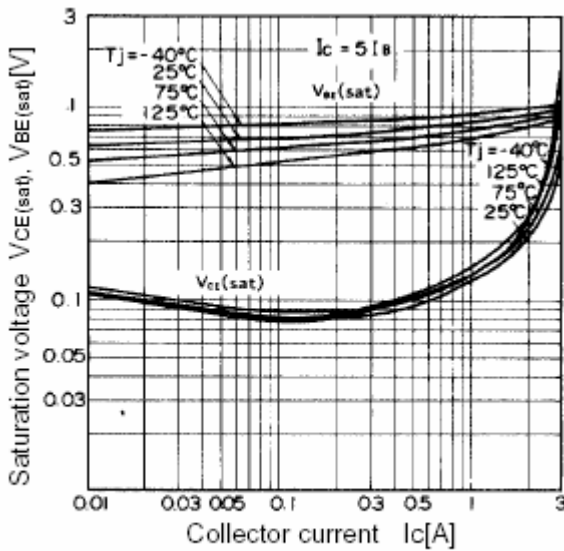

Fig.5 Base-Emitter Saturation Voltage
Collector-Emitter Saturation Voltage

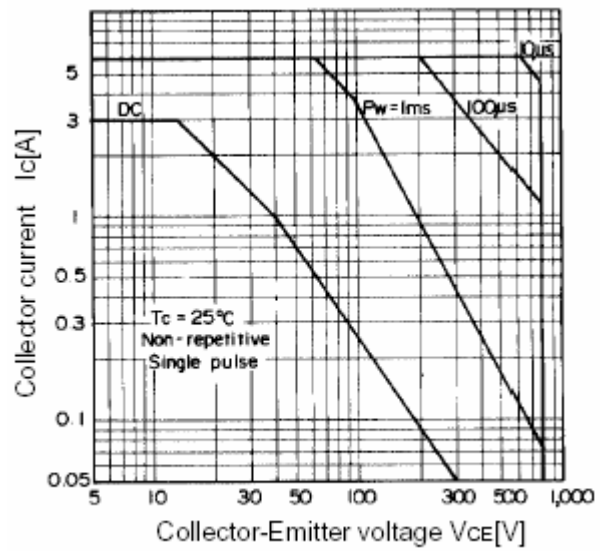

Fig.6 Safe Operating Area