

# AN7561Z

## BTL output power IC for car audio

### ■ Overview

The AN7561Z is an audio power IC developed as a car audio output (35 W × 4-ch). CR to stop oscillation is built in between the output pin and GND so that a space saving of set is possible. Also, it is incorporating a perfect muting circuit which does not make a shock noise so that a shock noise design in the set transitional state can be made easily when used together with its standby function. In addition, it is incorporating various protective circuits to protect the IC from destruction by GND-open earth short-circuiting and power supply surge which are the important subject of power IC, and the IC will largely contribute to a high reliability design of equipment.

### ■ Features

- Pin arrangement which does not allow the input/output patterns to intersect each other so that it is possible to make a pattern design on a one-sided printed circuit board.
- Incorporating various protection circuits (thermal protection, short-circuit to  $V_{CC}$ , short-circuit to  $V_{CC}$  in  $V_{CC}$ -opened, short-circuit to GND, short-circuit to GND in GND-opened, over voltage, power supply surge, and ASO protection, etc.)
- Incorporating standby function (shock noise-free at STB-on/off)
- Incorporating standby function (shock noise-free at Mute-on/off)
- External components reduction
- Provided with beep sound input pin
- Equipped with auxiliary sound input pin
- Inverted pin layout of AN7560Z on right and left pins

### ■ Applications

- Car stereo, miniature audio component, karaoke and other audio equipment.

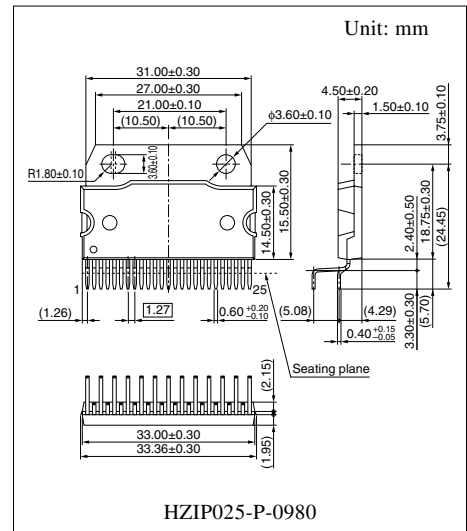

Note) The package of this product will be changed to lead-free type (HZIP025-P-0980B). See the new package dimensions section later of this datasheet.

## ■ Block Diagram

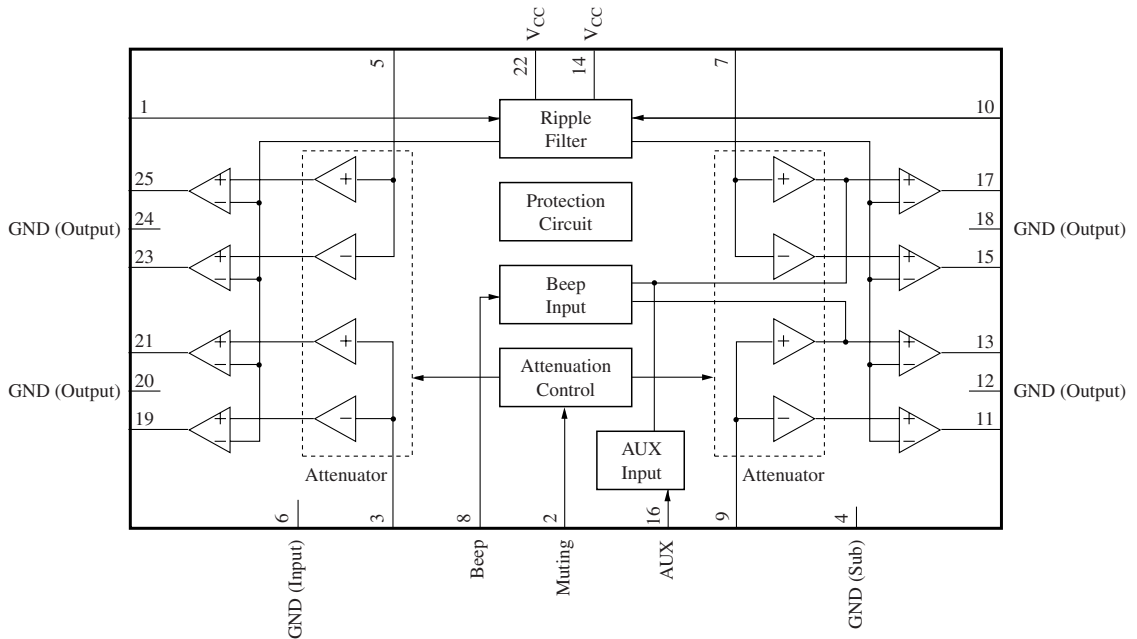

## ■ Pin Descriptions

| Pin No. | Description       | Pin No. | Description             |
|---------|-------------------|---------|-------------------------|
| 1       | Ripple filter     | 14      | Supply voltage $V_{CC}$ |
| 2       | Mute              | 15      | ch.2 – output           |
| 3       | ch.3 input        | 16      | AUX input               |
| 4       | GND (Sub)         | 17      | ch.2 + output           |
| 5       | ch.4 input        | 18      | GND (ch.2 output)       |
| 6       | GND (Input)       | 19      | ch.3 – output           |
| 7       | ch.2 input        | 20      | GND (ch.3 output)       |
| 8       | Beep input        | 21      | ch.3 + output           |
| 9       | ch.1 input        | 22      | Supply voltage $V_{CC}$ |
| 10      | Standby           | 23.     | ch.4 – output           |
| 11      | ch.1 – output     | 24      | GND (ch.4 output)       |
| 12      | GND (ch.1 output) | 25      | ch.4 + output           |
| 13      | ch.1 + output     |         |                         |

Note) The output pin requires no capacitor and resistor for oscillation prevention.

If those are required for countermeasure against noise, be sure to use after confirmation.

### ■ Absolute Maximum Ratings

| Parameter                        | Symbol      | Rating      | Unit |
|----------------------------------|-------------|-------------|------|
| Supply voltage *2                | $V_{CC}$    | 25          | V    |
| Peak power-supply-voltage *3     | $V_{Surge}$ | 65          | V    |
| Supply current                   | $I_{CC}$    | 12          | A    |
| Power dissipation *4             | $P_D$       | 59          | W    |
| Operating ambient temperature *1 | $T_{opr}$   | -30 to +85  | °C   |
| Storage temperature *1           | $T_{stg}$   | -55 to +150 | °C   |

Note) \*1 :  $T_a = 25\text{ °C}$  except power dissipation, operating ambient temperature and storage temperature.

\*2 : Without signal

\*3 : Time = 0.2 s

\*4 :  $T_a = 85\text{ °C}$

### ■ Recommended Operating Range

| Parameter      | Symbol   | Range       | Unit |
|----------------|----------|-------------|------|
| Supply voltage | $V_{CC}$ | 8.0 to 18.0 | V    |

### ■ Electrical Characteristics at $V_{CC} = 13.2\text{ V}$ , freq = 1 kHz, $T_a = 25\text{ °C}$

| Parameter                   | Symbol    | Conditions  | Min  | Typ  | Max | Unit          |
|-----------------------------|-----------|---|------|------|-----|---------------|
| Quiescent circuit current   | $I_{CQ}$  | $R_G = 10\text{ k}\Omega$ , $R_L = 4\text{ }\Omega$   | —    | 300  | 450 | mA            |
| Standby current             | $I_{STB}$ | $R_G = 10\text{ k}\Omega$ , $R_L = 4\text{ }\Omega$   | —    | 1    | 10  | $\mu\text{A}$ |
| Output noise voltage *1     | $V_{NO}$  | $R_G = 10\text{ k}\Omega$ , $R_L = 4\text{ }\Omega$   | —    | 0.15 | 0.5 | mV[rms]       |
| Voltage gain                | $G_V$     | $V_{IN} = 40\text{ mV}$ , $R_L = 4\text{ }\Omega$   | 32   | 34   | 36  | dB            |
| Total harmonic distortion 1 | THD1      | $V_{IN} = 40\text{ mV}$ , $R_L = 4\text{ }\Omega$   | —    | 0.05 | 0.2 | %             |
| Maximum output power        | $P_O$     | THD = 10%, $R_L = 4\text{ }\Omega$  | 16.0 | 19.5 | —   | W             |
| Ripple rejection ratio *1   | RR        | $R_L = 4\text{ }\Omega$ , $R_G = 10\text{ k}\Omega$ ,<br>$V_R = 1\text{ V[rms]}$ , fr = 1 kHz                               | 60   | 68   | —   | dB            |
| Channel balance             | CB        | $V_{IN} = 40\text{ mV}$ , $R_L = 4\text{ }\Omega$   | —    | 0    | 1   | dB            |
| Crosstalk                   | CT        | $V_{IN} = 40\text{ mV}$ , $R_L = 4\text{ }\Omega$ ,<br>$R_G = 10\text{ k}\Omega$  | 60   | 70   | —   | dB            |
| Output offset voltage       | $V_{OFF}$ | $R_G = 10\text{ k}\Omega$ , $R_L = 4\text{ }\Omega$   | -250 | 0    | 250 | mV            |
| Muting effect *1            | MT        | $V_{IN} = 40\text{ mV}$ , $R_L = 4\text{ }\Omega$   | 70   | 86   | —   | dB            |
| Input impedance             | $Z_I$     | $V_{IN} = \pm 0.3\text{ V}_{DC}$  | 24   | 30   | 36  | k $\Omega$    |
| Shock noise *2              | $V_S$     | $R_L = 4\text{ }\Omega$ , $R_G = 10\text{ k}\Omega$ ,<br>$V_{MUTE} = 5\text{ V}$ , $V_{STB} = \text{On/Off}$ ,<br>50 Hz HPF | -100 | 0    | 100 | mV[p-0]       |

Note) \*1 : Use 15 Hz to 30 kHz (12 dB/OCT) band-pass filter at measurement.

\*2 : Change over the standby pin at 0V and 5V with the following time.

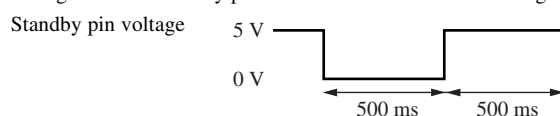

■ Electrical Characteristics at  $V_{CC} = 9\text{ V}$ ,  $T_a = 25\text{ °C}$  (continued)

| Parameter                   | Symbol            | Conditions  | Min | Typ | Max | Unit |
|-----------------------------|-------------------|---|-----|-----|-----|------|
| Total harmonic distortion 2 | THD2              | $V_{IN} = 20\text{ mV}$ , $f_{IN} = 20\text{ kHz}$ ,<br>$R_G = 10\ \Omega$ , $R_L = \infty$ | —   | 0.1 | 0.5 | %    |
| Mute-on threshold voltage   | MT <sub>ON</sub>  | $V_{IN} = 40\text{ mV}$ , $R_L = 4\ \Omega$   | 4   | —   | —   | V    |
| Mute-off threshold voltage  | MT <sub>OFF</sub> | $V_{IN} = 40\text{ mV}$ , $R_L = 4\ \Omega$   | —   | —   | 0.8 | V    |
| Cutoff frequency            | $f_C$             | $V_{IN} = 40\text{ mV}$ , $R_L = 4\ \Omega$<br>$G_V = -1\text{ dB}$ (0 dB: 1 kHz)           | 20  | 40  | —   | kHz  |

- Design reference data at  $V_{CC} = 13.2\text{ V}$ ,  $f = 1\text{ kHz}$ , measuring bandwidth 15 Hz to 30 kHz (12 dB/OCT) filter is used

Note) The characteristic values below are theoretical values for designing and not guaranteed.

| Parameter             | Symbol             | Conditions   | Min | Typ | Max | Unit |
|-----------------------|--------------------|--|-----|-----|-----|------|
| Maximum output power  | P <sub>Omax</sub>  | max. power, $R_L = 4\ \Omega$  | —   | 28  | —   | W    |
| Maximum output power  | P <sub>O2</sub>    | $V_{CC} = 14.4\text{ V}$ , THD = 10%,<br>$R_L = 4\ \Omega$   | —   | 21  | —   | W    |
| Maximum output power  | P <sub>Omax2</sub> | $V_{CC} = 14.4\text{ V}$ , max. power,<br>$R_L = 4\ \Omega$  | —   | 34  | —   | W    |
| Power band            | $f_{PL}$           | $V_{CC} = 14.4\text{ V}$ , THD = 1%,<br>$R_L = 4\ \Omega$ ,<br>$P_{OL} = -3\text{ dB}$ (1 kHz: 0 dB) | —   | 10  | —   | Hz   |
| Power band            | $f_{PH}$           | $V_{CC} = 14.4\text{ V}$ , THD = 1%,<br>$R_L = 4\ \Omega$ ,<br>$P_{OH} = -3\text{ dB}$ (1 kHz: 0 dB) | —   | 18  | —   | kHz  |
| STB threshold voltage | V <sub>STB1</sub>  | $R_G = 10\text{ k}\Omega$ , $R_L = 4\ \Omega$ ,<br>STB→ACT   | —   | 2.2 | —   | V    |
| STB threshold voltage | V <sub>STB2</sub>  | $R_G = 10\text{ k}\Omega$ , $R_L = 4\ \Omega$ ,<br>ACT→STB   | —   | 1.5 | —   | V    |

■ Terminal Equivalent Circuits

| Pin No. | Equivalent circuit | Description   | DC Voltage    |
|---------|--------------------|---|---------------|
| 1       |                    | Ripple filter pin:<br>Output current from 3 mA to 10mA                        | 13 V          |
| 2       |                    | Mute pin:<br>Mute switchover pin<br>Threshold voltage about 2.1 V             | 0 V           |
| 3       |                    | ch.3 input pin:<br>ch.3 input signal application pin<br>Input impedance 30 kΩ | 0 mV to 10 mV |
| 4       | —                  | GND (circuit board): Circuit board  | 0 V           |
| 5       |                    | ch.4 input pin:<br>ch.4 input signal application pin<br>Input impedance 30 kΩ | 0 mV to 10 mV |

■ Terminal Equivalent Circuits (continued)

| Pin No. | Equivalent circuit | Description  | Voltage       |
|---------|--------------------|--|---------------|
| 6       | —                  | GND (input): Grounding pin for input   | 0 V           |
| 7       |                    | ch.2 input pin:<br>ch.2 input signal application pin<br>Input impedance 30 kΩ    | 0 mV to 10 mV |
| 8       |                    | Beep sound input pin:<br>Beep sound signal input pin<br>Input impedance 15 kΩ    | 0 V           |
| 9       |                    | ch.1 input pin:<br>ch.1 input signal application pin<br>Input impedance 30 kΩ    | 0 mV to 10 mV |
| 10      |                    | Standby control pin:<br>Standby switch over pin<br>Threshold voltage about 2.1 V | 5 V           |

■ Terminal Equivalent Circuits (continued)

| Pin No. | Equivalent circuit | Description  | Voltage |
|---------|--------------------|--|---------|
| 11      |                    | ch.1 output pin (-):<br>ch.1 negative phase output pin   | 6.3 V   |
| 12      | —                  | GND (output):<br>Grounding pin for ch.1 output           | 0 V     |
| 13      |                    | ch.1 output pin (+):<br>ch.1 positive phase output pin   | 6.3 V   |
| 14      | —                  | Power supply voltage pin:<br>Power supply connection pin | 13.2 V  |
| 15      |                    | ch.2 output pin (-):<br>ch.2 negative phase output pin   | 6.3 V   |
| 16      |                    | AUX input pin:<br>Input impedance 10.6 kΩ                | 6.3 V   |

### ■ Terminal Equivalent Circuits (continued)

| Pin No. | Equivalent circuit | Description  | Voltage |
|---------|--------------------|--|---------|
| 17      |                    | ch.2 output pin (+):<br>ch.2 positive phase output pin   | 6.3 V   |
| 18      | —                  | GND (output):<br>Grounding pin for ch.2 output           | 0 V     |
| 19      |                    | ch.3 output pin (-):<br>ch.3 negative phase output pin   | 6.3 V   |
| 20      | —                  | GND (output):<br>Grounding pin for ch.3 output           | 0 V     |
| 21      |                    | ch.3 output pin (+):<br>ch.3 positive phase output pin   | 6.3 V   |
| 22      | —                  | Power supply voltage pin:<br>Power supply connection pin | 13.2 V  |



■ Terminal Equivalent Circuits (continued)

| Pin No. | Equivalent circuit | Description  | Voltage |
|---------|--------------------|--|---------|
| 23      |                    | ch.4 output pin (-):<br>ch.4 negative phase output pin | 6.3 V   |
| 24      | —                  | GND (output):<br>Grounding pin for ch.4 output         | 0 V     |
| 25      |                    | ch.4 output pin (+):<br>ch.4 positive phase output pin | 6.3 V   |

## ■ Application Circuit Example

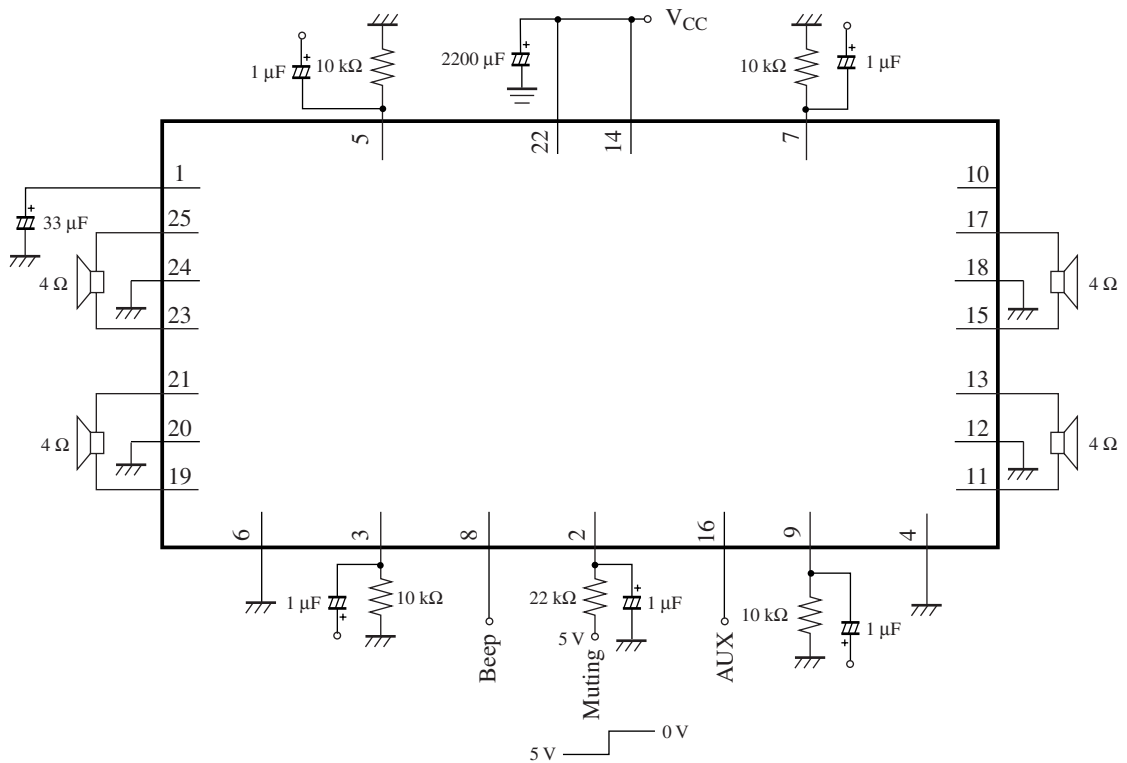

## ■ Usage notes

1. Be sure to use the circuit with an external heat-sink and fix the external heat-sink on chassis when using it.
2. Connect the heat radiating fin to GND potential.
3. This IC has built-in protection circuit against short-circuit to  $V_{CC}$ , short-circuit to GND and ASO. However avoid short-circuit to  $V_{CC}$ , short-circuit to GND and short-circuit of load.
4. The thermal protection circuit operates at  $T_j =$  about  $150\text{ }^{\circ}\text{C}$  but it automatically returns to the normal operation when the temperature decreases.
5. The over voltage protection circuit operates at  $V_{CC} =$  about  $20\text{ V}$ .
6. Be especially careful to heat radiation design when used at an increased  $V_{CC}$ .
7. Connect the beep sound input pin to GND when the beep sound function is not used.
8. Do not lower the beep sound input pin below  $-0.3\text{ V}$ .
9. Keep AUX input pin in open state when AUX function is not used.
10. Connect only GND pin (signal source) to the signal GND of the amplifier in previous stage.

### • There is a possibility of device destruction under the following conditions;

1. If the power supply pin and GND pin are connected in reverse to the power supply.
2. If the power supply pin and GND pin are in open state and the power supply is connected across the output pins.
3. If the output pin is grounded when GND pin is open.
4. If more than three output pins are grounded to the earth at a time with more than  $1.3\text{ }\Omega$  short-circuiting resistor with which the protection circuit does not operate.
5. If plus and minus output pins are short circuited to the supply line at a time with more than  $1\text{ }\Omega$  short-circuiting resistor with which the protection circuit does not operate.
6. If the RF pin and the output pin are short circuited and short-circuited to the earth.

■ Technical Information

- HZP025-P-0980 package power dissipation

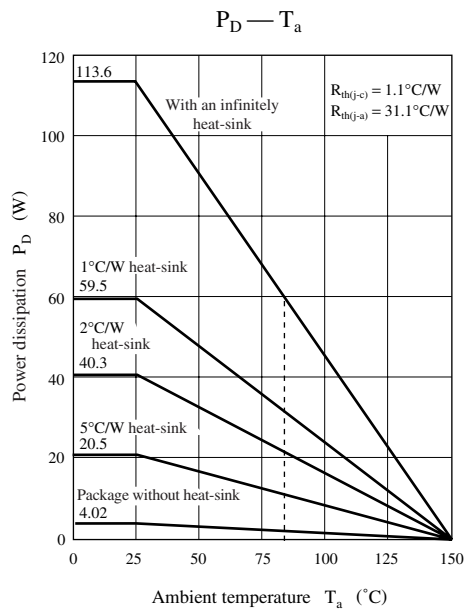

■ New Package Dimensions (Unit: mm)

- HZIP025-P-0980B (Lead-free package)

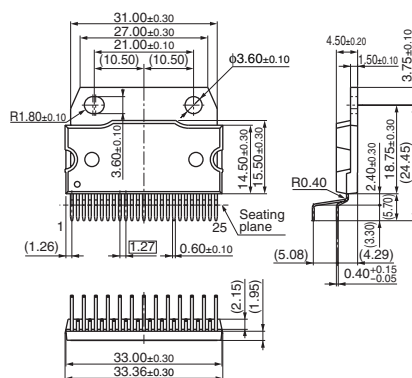

## Request for your special attention and precautions in using the technical information and semiconductors described in this material

- (1) An export permit needs to be obtained from the competent authorities of the Japanese Government if any of the products or technologies described in this material and controlled under the "Foreign Exchange and Foreign Trade Law" is to be exported or taken out of Japan.
- (2) The technical information described in this material is limited to showing representative characteristics and applied circuit examples of the products. It does not constitute the warranting of industrial property, the granting of relative rights, or the granting of any license.
- (3) The products described in this material are intended to be used for standard applications or general electronic equipment (such as office equipment, communications equipment, measuring instruments and household appliances).  
Consult our sales staff in advance for information on the following applications:
  - Special applications (such as for airplanes, aerospace, automobiles, traffic control equipment, combustion equipment, life support systems and safety devices) in which exceptional quality and reliability are required, or if the failure or malfunction of the products may directly jeopardize life or harm the human body.
  - Any applications other than the standard applications intended.
- (4) The products and product specifications described in this material are subject to change without notice for reasons of modification and/or improvement. At the final stage of your design, purchasing, or use of the products, therefore, ask for the most up-to-date Product Standards in advance to make sure that the latest specifications satisfy your requirements.
- (5) When designing your equipment, comply with the guaranteed values, in particular those of maximum rating, the range of operating power supply voltage and heat radiation characteristics. Otherwise, we will not be liable for any defect which may arise later in your equipment.  
Even when the products are used within the guaranteed values, redundant design is recommended, so that such equipment may not violate relevant laws or regulations because of the function of our products.
- (6) When using products for which dry packing is required, observe the conditions (including shelf life and after-unpacking standby time) agreed upon when specification sheets are individually exchanged.
- (7) No part of this material may be reprinted or reproduced by any means without written permission from our company.

## Please read the following notes before using the datasheets

- A. These materials are intended as a reference to assist customers with the selection of Panasonic semiconductor products best suited to their applications.  
Due to modification or other reasons, any information contained in this material, such as available product types, technical data, and so on, is subject to change without notice.  
Customers are advised to contact our semiconductor sales office and obtain the latest information before starting precise technical research and/or purchasing activities.
- B. Panasonic is endeavoring to continually improve the quality and reliability of these materials but there is always the possibility that further rectifications will be required in the future. Therefore, Panasonic will not assume any liability for any damages arising from any errors etc. that may appear in this material.
- C. These materials are solely intended for a customer's individual use.  
Therefore, without the prior written approval of Panasonic, any other use such as reproducing, selling, or distributing this material to a third party, via the Internet or in any other way, is prohibited.