

# SANGENS

Installation and Operation MANUAL

## Electric heater for steam-sauna and classic sauna

Sangens 12B, 20B

Sangens 12G, 20G

Sangens 12S, 20S

Sangens 30B, 40B

Sangens 30G, 40G

Sangens 30S, 40S

**You have chosen just  
the right product of  
supreme quality!**

Make sure you comply with this Manual to fully enjoy the perfect quality and maximum service life of Sangens heaters.

Read the Manual thoroughly before starting the installation and operation of the heater. Keep the Manual for further reference.





Sangens 12B, 20B



Sangens 30B, 40B



Sangens 12G, 20G



Sangens 30G, 40G



Sangens 12S, 20S



Sangens 30S, 40S

## CONTENTS

<b>Technical features</b>	<b>4</b>
<b>1. GENERAL</b>	<b>5</b>
<b>2. OPERATION MANUAL</b>	<b>5</b>
2.1. Safety precautions	5
2.2. Design and operating principles of the electric heater	5
2.3. Operation of the electric heater	6
2.4. Stones to be used with the heater	7
2.5. Water to be used in the sauna	8
2.6. Steam-sauna ventilation	8
2.7. Safe distance	9
2.3. Maintenance	9
2.9. Potential failures and troubleshooting methods	10
<b>3. TRANSPORTATION, STORAGE, DISPOSAL</b>	<b>11</b>
3.1. Transportation	11
3.2. Storage	11
3.3. Disposal	11
<b>4. WARRANTY STATEMENT</b>	<b>12</b>
<b>5. INSTALLATION MANUAL</b>	<b>12</b>
5.1. Pre-installation activities	12
5.2. Installation of the heater	12
<b>APPENDIX 1. Electric heater design components</b>	<b>14</b>
<b>APPENDIX 2. Connecting the electric heater</b>	<b>15</b>
<b>APPENDIX 3. Installing the component parts of the heater</b>	<b>19</b>
<b>APPENDIX 4. Professional power control unit</b>	<b>35</b>
<b>APPENDIX 5. Power control unit with Bluetooth</b>	<b>41</b>
<b>APPENDIX 6. SANGENS Control Mobile Application</b>	<b>55</b>
<b>APPENDIX 7. Scope of supply</b>	<b>57</b>

Table 1. Technical features

Characteristics	pcs.	Sangens W12			Sangens W20			Sangens W30			Sangens W40		
		Brick	Glass	Stone	Brick	Glass	Stone	Brick	Glass	Stone	Brick	Glass	Stone
Room space: classic sauna	m3	9			18			26			36		
Room space: steam-sauna	m3	12			20			30			40		
Weight of stones in closed heater	max kg	25 / 45			25 / 45			50 / 90			50 / 90		
Weight of stones in outer heater	max kg	15	5	5	15	5	5	35	30	35	35	30	35
Stone size, closed heater	mm	50-80			50-80			50-80			50-80		
Stone size, open heater	mm	30-40			30-40			30-40			30-40		
Rated power consumption	kW	6			9			15			18		
Connection type	-	1P\2P+N+PE			3P+N+PE			3P+N+PE			3P+N+PE		
Rated voltage	V	220 ± 7.5 %			220 ± 7.5 %			220 ± 7.5 %			220 ± 7.5 %		
Rated current, protected circuit breaker	A	1P-32A\2P-25A			3P-25A			3P-32A			3P-32A		
Wire cross-section, power and earthing cables	mm <sup>2</sup>	4 \2.5			2.5			4			4		
Frequency	Hz	50			50			50			50		
Type of current	-	alternate / AC			alternate / AC			alternate / AC			alternate / AC		
Electric shock hazard protection rating	-	I			I			I			I		
Enclosure protection rating	-	IPX4			IPX4			IPX4			IPX4		
Weight	kg	160	78	221	161	79	222	286	89	314	287	90	316
Width	mm	540	415	495	540	415	495	955	800	990	955	800	990
Height	mm	940	910	955	940	910	955	945	910	955	945	910	955
Depth	mm	540	415	495	540	415	495	550	415	495	550	415	495

Note: sizes of the electric heater are specified in Appendix 1

**\* Total weight if filled with stones / with mix of stones and stainless steel infill parts**

## **1. GENERAL**

*WARNING! Be sure to choose just the right heater that fits your room best. A heater of smaller capacity would need to be turned on more often and for a longer time, which would decrease its expected service life.*

Note the following aspects:

When selecting an electric heater, pay attention to the materials that the walls and the ceiling in your room are made of. In case the ceiling and the walls are not covered with a heat insulation layer (e.g. bare concrete, brick, glass, etc.), an electric heater of greater capacity is required; when calculating, add 1.2 m<sup>3</sup> for each square meter of surface of walls and ceiling made of such materials. Should the room walls be made of massive timber, the estimated volume is calculated applying a ratio of 1.5.

### *Example 1:*

The sauna room space is 10 m<sup>3</sup>. A sauna has a brick wall with a 3 m length and 2 m height. Calculation:  $10+2 \times 3 \times 1.2 = 17.2$ . This means that this room is equivalent to a sauna room of about 17 m<sup>3</sup>.

### *Example 2:*

The sauna room space is 10 m<sup>3</sup>. A sauna has a glass door with a 0.8 m width and 2 m height. Calculation:  $10+2 \times 0.8 \times 1.2 = 11.9$ . This means that this room is equivalent to a sauna room of about 12 m<sup>3</sup>.

### *Example 3:*

The sauna room space is 10 m<sup>3</sup>. The walls in this sauna are made of heavy timbers. Calculation:  $10 \times 1.5 = 15$ . This means that this room is equivalent to a sauna room of about 15 m<sup>3</sup>.

## **2. OPERATION MANUAL**

Read this Manual thoroughly before starting the installation and operation of the heater. Keep the Manual for further reference.

### **2.1. Safety precautions**

*WARNING! Consult a doctor to find out if you have any health-related restrictions. Bear in mind: staying in a hot sauna for a long period may harm your health. Do not stay in a heated-up sauna or steam-sauna room if under alcohol, drugs, medicine, etc. Do not sleep in a heated-up sauna. Beware of wet and slippery sauna floor while walking.*

*WARNING! Consult a pediatrician to find out if your child is allowed to stay in the sauna or steam-sauna. Keep the children away from the heater. Do not leave the children or people with physical limitations or medical conditions unattended in the sauna.*

*WARNING! Beware of the hot parts of the heater and the stones. To avoid scalds, never add steam if you or another person are close to the heater.*

*WARNING! To avoid fire, never dry your clothes or other belongings in the steam room or on the heater.*

*WARNING! As this electric heater is an electrical unit, it must be installed, operated and maintained in compliance with the latest technical enactments, technical regulations and rules (for Russia, e. g. PUE (Electrical Installation Code), PTEEB (Regulations for Operation of Consumer Electrical Installations), PTBEP (Safety Rules for Operation of Consumer Electrical Installations), etc.).*

*Note: steel surfaces of the heater may be subject to corrosion if kept in wet or oceanic climate, or if kept without being dried properly.*

### **2.2. Design and operating principles of the electric heater**

*Note: general layout and main elements arrangement of the electric heater is specified in Appendix 1.*

The electric heater maintains the steam room heated and provides certain combinations of various temperature and humidity through separate functioning of the convection heater and heating parts of the closed heater.

The stone heater can be outfitted with a professional control unit or a Bluetooth-operated control unit. Unique in its design, the Bluetooth control unit is simple to use and operate. The professional control unit design incorporates industrial components, it offers high reliability and improved service life. Choose your control unit based on your own preferences and the operating environment of the heater.

The viewscreen of the control unit displays data related to the temperature transmitters inside the closed heater and inside the steam room; the heater adjusts the operation, if necessary. The control program of the electric heater has integrated features limiting the device operating time, as well as monitoring the consistency between the temperature modes and the heating parts operation modes. Additionally, an emergency alarm system and a system controlling the heater functions from mobile devices via SANGENS app (available for Bluetooth control units), are in place.

***WARNING! Any unauthorized modifications of the electric heater or the control unit are strictly prohibited. The Manufacturer reserves the right to introduce any change into the design of the electric heater that does not impair its usability.***

Special steam, finely dispersed and light, is obtained by adding water to the closed heater, with the stones at 350 °C or higher. If the stone heater cover is closed tightly, without any gap, then, as the pressure builds up, the steam goes through the nozzle in the cover, producing sounds of a blizzard.

*Note: the blizzard sound volume is adjusted by changing the clamping force of the heater cover.*

W30 and W40 heater designs combine W12 and W20 heaters:

The W30 is a combination of W12 and W20 heaters, 6 kW and 9 kW, respectively;

The W40 is a combination two W20 heaters, 9 kW each.

Therefore, should the heating capacity of a single W12 or W20 heater be found insufficient to achieve the required temperature in the steam room, you can modify it by installing one or more additional electric heaters.

You can install and connect the said additional heaters to the power grid and control unit as a standalone device or add them to the existing one. If the first option is selected, the initial (individual) cladding style may remain, while with the second option, extended cladding coverage may be provided to encompass the entire group of heaters.

***WARNING! In case a single heater is modified into a new arrangement, the control unit needs to be replaced with a new one, accordingly.***

The heating capacity of the W12 electric heater can be alternatively increased by replacing the convection heater with a more powerful one.

Whichever modification is made, the existing connection scheme will need to be rearranged to avoid short-circuiting or burnout of the heaters.

***WARNING! Make sure the cross-section and the quantity of conductors is in line with the connection arrangement, with due regard to the modifications made (Appendix 4, 5).***

### **2.3. Operation of the electric heater**

***WARNING! Before switching it on, make sure the electric heater and the wires are intact and the power grid is online.***

*Remove all packaging items, including any stickers or magnets, before starting the heater for the first time.*

- 1.** Turn on the device.

2. Choose the required operation mode of the heater using the mobile app (available for Bluetooth control units, Appendix 5) or the keys on the control unit panel. The operating mode parameters are specified in Table 2.
3. As soon as the preset temperature in the steam room is reached, the control unit switches off the convection heater in the device. Both the control unit viewscreen and the mobile app show the data related to readiness (status) of the sauna.
4. The control unit switches off the heating parts in the device upon reaching the preset temperature in the closed heater.
5. Ventilate the steam room upon completion of steam bathing activities. To do that, select the Dry mode on the control unit or in the mobile app, and the heater will automatically switch off after 40 minutes of operation.
6. Activate the Heating mode to maintain the temperature in the heated steam room.

**WARNING!**

- *Partial burnout of heat-resistant enamel is possible at the most heat-loaded components of the electric heater; this is not a product defect.*
- *As the electric heater operation progresses, the steel parts can become slightly deformed, which cannot be deemed product defect as long as the weld seams remain intact.*

**WARNING!** *It is prohibited to use the electric heater without a protection screen on the convection heater.*

**Table 2.** Operation mode of the electric heater

		Classic sauna Classic sauna	Steam-sauna	Dry	Heating	ECO mode*
Air temperature	°C	90-100	65-80	90	10-28	*
Temperature in closed heater	°C	400	500-530	turned off	turned off	*
Humidity	%	**	**	**	**	**

\* ECO mode implies restriction of the maximum power capacity (available for devices outfitted with Bluetooth control units). With this mode selected, the closed heater and the convection heater operate alternately, until the set temperature is reached.

\*\* Air humidity depends on the amount of water supplied.

**WARNING!** *In order to set up the required temperature in the steam room, temperature modes can be combined in different ways within the preset ranges; e. g. the indoor air temperature will be 0-90 °C (or 110 °C for a short time period), and the temperature inside the closed heater 300-530 °C (or 550 °C for a short time period).*

*Note: at low temperatures, the closed heater generates less steam that becomes more moist, and there may be no sounds of blizzard generated, which is not deemed a defect or failure of the electric heater.*

## 2.4. Stones to be used with the heater

Permissible stone size can be found in Table 1.

The process of stone laying into the heater can be found in section "Laying stones into a closed heater or an outer heater" (Appendix 3).

*WARNING! Fill the outer heater bowl only with tumbled stone types, to prevent damage to the cladding; the total weight and dimensions of the stones must not exceed the values specified in Table 1. Fill the closed heater with stone types suitable for sauna use and resistant to high temperatures.*

*WARNING! Lay the stones into the closed heater only after its complete cooldown.*

*WARNING! Never pour water into the closed heater to accelerate the cooldown of stones and heating elements.*

- Prior to laying stones into the closed heater, clean them of any dirt or dust and rinse them in water.
- Put larger stones on the very bottom of the heater and smaller stones on the top.

*WARNING! For steam rooms with higher loads, as well as to generate more steam of better quality, it is recommended to use a combination of premium stones and infill parts made of stainless steel, with the stone weight not more than 20 kg and the steel infill weight not more than 25 kg.*

*WARNING! It is prohibited to fill the heaters with rock salt.*

## **2.5. Water to be used in the sauna**

The water to be supplied to the stones needs to be pure main water. Make sure you have water of proper quality. If the water has high content of ferrum, salts, humus or lime, this can cause corrosion developing rapidly on the parts of the heater. For example, sea water quickly entails corrosion inside the heater. The quality of the mains water must comply with the following requirements:

- humus <12 mg/l;
- Fe <0.2 mg/l;
- Ca <100 mg/l;
- Mn <0.05 mg/l.

*WARNING! Pour water solely onto the stones. Never pour water on heated steel or glass surface as it may get warped due to severe temperature drop.*

*WARNING! Never use salt solution to generate steam: do not pour it into the closed heater or onto outer surfaces of the electric heater.*

*WARNING! In order to avoid flooding the closed heater and to ensure longer service life of the electric heater, add water in two or three iterations, each time not more than 600 ml, with a time gap of 10-15 minutes.*

## **2.6. Steam-sauna ventilation**

### **1) Natural ventilation (Fig. 1):**

**Inlet vent hole (A)** must be located close to the floor near the electric heater.

The inlet vent hole is needed to ensure fresh air supply to the sauna.

**Outlet vent hole (B)** must be located under the ceiling, as far as possible from the electric heater. The outlet vent hole is needed primarily to ensure moisture discharge from the sauna after the steaming is over.

### **2) Mechanical induced draft ventilation (Fig. 2):**

**Inlet vent hole (A)** must be located at a height of about 500 mm above the electric heater.



Outlet vent hole (B) must be located as close as possible to the floor, e. g. under the sweating shelf.

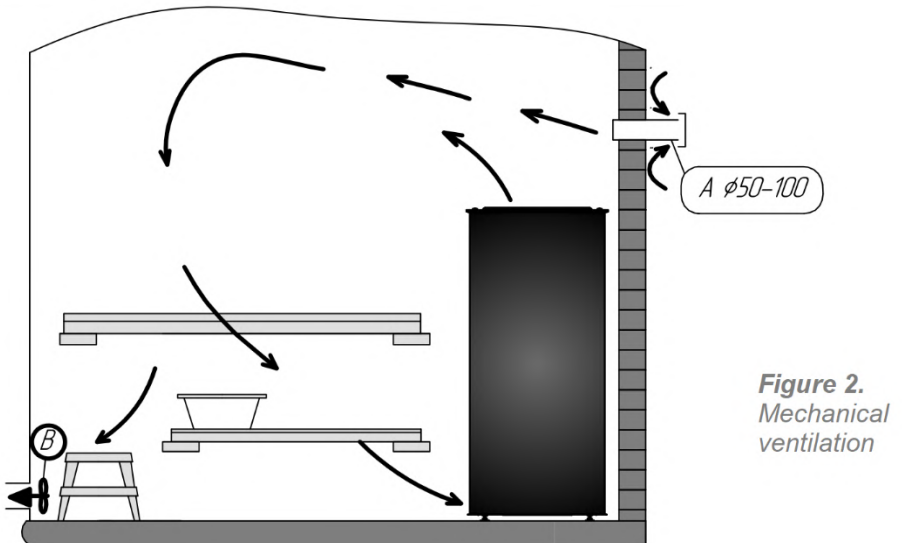
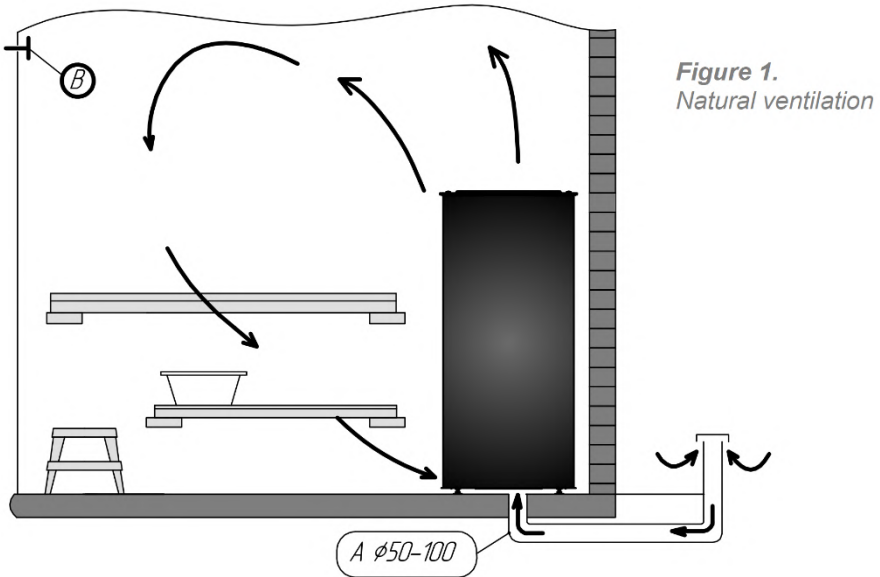

## 2.7. Safety distance

**WARNING!** In order to ensure proper air circulation around the electric heater, maintain the required distance between the room walls and the heater.

### Minimum safety distance:

- **1200 mm** from the top of the heater to the ceiling made of non-flammable materials;  
**1400 mm** if made of flammable materials.
- **100 mm** from the side, rear and front walls of the electric heater to surfaces made of non-flammable materials; **200 mm** if made of flammable materials.

If the electric heater is installed in a recess in the room, the minimum safety distance from the side, rear and front walls of the heater to the surfaces made of non-flammable materials must be **150 mm**, or **300 mm** for flammable materials.

*Note: if the electric heater is placed in violation of the safety distance, then certain additional protection with heat insulation needs to be arranged.*

**WARNING!** In case the electric heater is installed at the sweating shelf with a decorative frame (Appendix 4, Decorative grill), the minimum safety distances, as specified above, need to be respected, too.

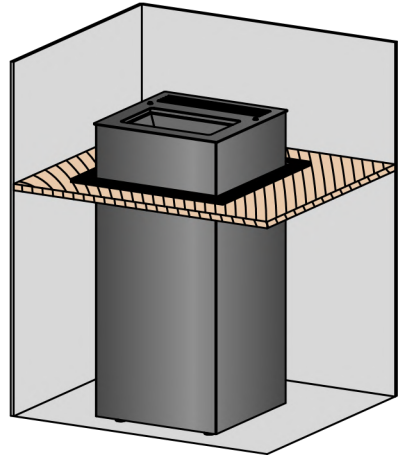

## 2.8. Maintenance

**Maintaining the electric heater and its component parts in a regular manner will ensure their highly efficient and reliable operation, and guarantee your safety.**

**WARNING!** All maintenance activities must be performed by specialists that have at least grade III electric safety qualification.

All maintenance activities must be performed only if disconnected from the power grid, in compliance with the latest technical enactments, technical regulations and rules (for Russia, e. g. PUE (Electrical Installation Code), PTEEB (Regulations for Operation of Consumer Electrical Installations), PTBEP (Safety Rules for Operation of Consumer Electrical Installations), etc.).

Maintenance of the electric heater must include the following works:

- Checking the condition of the earthing system and the reliability of the power contact torquing at the electric heater and the power unit, twice per year;
- Checking the protection earthing, once per month.
- Inspection of the insulation, the connection wire contacts, the convection heater terminal leads, the electric heater terminals: once per three months. • Cleaning the contact surfaces from scale and oxides: once per three months.

**WARNING!** Maintenance of the electric heater may start only after its cooldown is complete and power supply source has been disconnected.

**Stones** get gradually destroyed as the heater operates and therefore need to be removed, inspected and re-laid into the heater once again at least once per year, if your heater is in frequent operation. Remove damaged stones and stone fragments from the stove, put new stones inside. Before putting the stones inside, clean the heater surface with a wet wipe.

**WARNING!** On discovering signs of leak on the heating element leads and/or the upper surface of the convection heater, check the closed stone stove for water leakage, and contact SANGENS service, if required.

## 2.9. Potential failures and troubleshooting methods

### 1) Malfunction: Smell occurring during operation.

#### Potential reasons:

- Factory oils remaining on the heater surface, and/or smell is produced by the heat-resistant enamel.
- The stone stove can enhance the smells already present indoors, even if the source is not the sauna or the stove itself. Particularly, smells can be generated by surfaces coated with paint, oil, glue, or other substances.
- Foreign objects are stuck inside the convection channel (tree leaves, branches, debris).

#### Troubleshooting:

- Turn the electric stone heater on for one hour, Classic Sauna mode, to remove the oil residuals on the steel surface or volatile components of the heat-resistant enamel. • Choose only suitable materials for treating the sauna surfaces, and use them according to the relevant manual.
- Remove the foreign objects from the convection channel, having preliminarily dismantled the upper part of the electric heater cladding.

### 2) Malfunction: Sauna room is not getting heated.

#### Potential reasons:

- The room is too large for the electric heater's heating capacity to handle it.
- Heat insulation in the building does not correspond to the requirements.
- Power voltage is lower than nominal.
- Failure of the convection heater.
- Heating elements chain is not intact.

#### Troubleshooting:

- Check the compliance if the electric heater power capacity to the sauna dimensions.
- Check the heat insulation of the room.
- Normalize the incoming power voltage.
- Call SANGENS service or a qualified professional.

### 3) Malfunction: The temperature in the steam room or the closed heater fails to adjust.

#### Potential reasons:

- Air sensor installed incorrectly.
- Sensor(s) breakdown.
- Control unit malfunction.

#### Troubleshooting:

- Check whether the sensor(s) is (are) installed correctly.
- Call SANGENS service or a qualified professional.

### 4) Malfunction: Smoke.

#### Potential reasons:

- Loss of electric wire integrity.
- Foreign objects are stuck inside the convection channel (tree leaves, branches, debris).

#### Troubleshooting:

- Check the wire integrity.
- Call SANGENS service or a qualified professional. • Remove the foreign objects from the convection channel, having preliminarily dismantled the upper part of the electric heater cladding.

### 5) Malfunction: error message "-----" appears on the control unit screen.

#### Potential reasons:

- Error in connecting sensor(s), loss of sensor(s) control.

- Nonobservance of connection polarity.
- Loose contact at the connection between the wire and the sensor(s).
- The sensor of the closed heater short-circuiting against the electric heater housing.

Troubleshooting:

- Check the correctness of the sensor(s) connection (Appendices 4, 5, Connection diagrams).
- Check the correctness of connection (Appendices 2, Closed heater sensor).
- Check the connection between the wire and the sensor(s).
- Check the resistance between the sensor and the electric heater housing (Appendix 2, Sensor in the closed heater).

### 3. TRANSPORTATION, STORAGE, DISPOSAL

#### 3.1. Transportation

Before transporting the products, ensure they are properly fastened to secure their stable position and prevented from displacing or hitting each other. During the transportation and handling operations, the handling signs on the transportation packaging need to be respected. The products may be carried, if properly packed, with any means of transportation.

#### 3.2. Storage

The storage conditions specified below apply to both Supplier storage facilities and Consumer storage facilities.

Storage conditions: per GOST 15150-69 standard, gr. 3 (naturally ventilated, closed building without artificially regulated climatic conditions, ensuring protection from precipitation and direct sunlight), in the factory packaging (intact), vertically oriented, at a temperature of 60 °C to + 40 °C

*Note: The product storage environment must not contain any aggressive impurities (acid vapors or alkali).*

The maximum storage time in factory packaging until re-preservation is 12 months.

*WARNING! If the product is stored in a place with high humidity, the non-painted surfaces may show signs of surface corrosion that have no impact on operational features of the products, which is not a defect of the product.*

#### 3.3. Disposal

Upon completion of its service life, hand over the product to the relevant receiving point, so that the electric and electronic components are further recycled.

### 4. WARRANTY STATEMENT

**In household use**, the Warranty period for the Product, if complying with the operation manual, will be **60 months or 5,000 hours of operation**, whichever comes first, from the date the Product is purchased by the Buyer, subject to having put all the relevant marks on the last page of the Warranty Card, however **not more than 72 months** from the date of the Product shipment from the Manufacturer's warehouse to the Seller. **In commercial use**, the Warranty period for the Product, if complying with the operation manual, will be **12 months or 5,000 hours of operation**, whichever comes first, from the date the Product is purchased by the Buyer, subject to having put all the relevant marks on the last page of the Warranty Card, however **not more than 24 months** from the date of the Product shipment from the Manufacturer's warehouse to the Seller.

The Warranty period for the **Control unit** is **12 months** from the date the Product is purchased by the Buyer, subject to having put all the relevant marks on the last page of the Warranty Card, however **not more than 24 months** from the date of the Product shipment from the Manufacturer's warehouse to the Seller.

*WARNING! To avoid misunderstanding, make sure your warranty card is properly filled.*

Note: household use implies non-commercial use of the Product on periodic basis, with 6 hours operating time per week and about 300 hours operating time per year.

In case the Buyer finds the Product's non-compliance to the stated features, the Buyer may file a Claim to the Seller from which the product was bought. The Seller may turn to the Manufacturer to solve the Claim-related matter. The Manufacturer shall correct or improve the Product in full or in part, at no extra charge, or replace the entire Product or its part, component (as may be agreed upon with the Buyer), in case the defect occurred within the warranty period or due to the Manufacturer's fault. Should the Buyer make any change to the Product, its part/parts or component, the Product will lose the warranty coverage. The warranty does not cover the cladding parts and elements that need periodic replacement during the operation: e. g. sealing cords etc. Warranty service does not cover the damage inflicted due to Buyer's failure to follow the requirements provided for herein, misuse of the Product, violation of fire safety rules, damage of the paint coat, defects caused by mechanic impact, improper storage, installation, operation, not resulting from the Manufacturer's fault. The Buyer's noncompliance, as mentioned above, relieve the Manufacturer from liability.

## 5. INSTALLATION MANUAL

### 5.1. Pre-installation activities

**WARNING!** Make sure the safety distance is maintained from all sides around the heater. No electric device, wire, low-melting or flammable materials must be located within the safety distance.

The electric heater must be installed in compliance with the latest technical enactments, technical regulations and rules (for Russia, e. g. PUE, PTEEB, PTBEP, etc.).

- Additional information on fire safety requirements can be obtained from the local fire fighting service.
- Check the availability of all component parts of the electric heater. Check the torquing of bolt connections all around the electric heater.

### 5.2. Installation of the heater

**WARNING!** All installation and maintenance activities must be performed by specialists that have at least grade III electric safety qualification.

1. Place the electric heater in the installation point inside the steam room and fine-tune the level by adjusting the height of the legs.

**WARNING!** A gap needs to be arranged between the heater base and the floor to ensure air circulation inside the heater:

22-25 mm for Brick cladding; 35-40 mm for Stone cladding;  
25-30 mm for Glass cladding.

Note: the electric heater must be installed in such way that the convection channel is placed against the wall: this will prevent the users from being exposed to the water and hot steam.

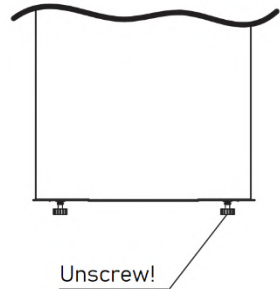

2. Attach the closed heater sensor to the terminal module of the electric heater (Appendix 2).
3. Install the control unit in a room adjacent to the steam room at eye level, connect it to the power grid and to the heater according to the connection diagram (Appendix 4, 5).

**4.**        **Install the air temperature sensor** directly in the room where the electric heater is located (Appendix 2).

**5.**        **Check the connections after all the hook-ups are made** and supply power to the control unit. Make sure the electric heater and the sensors are operable, switch off the power, place the stones in the closed heater and proceed with assembling and installing the cladding (Appendix 3).

## APPENDIX 1.

### Heater design elements:

1. Electric heater casing
2. Closed heater
3. Convection heater
4. Convection channel
5. Outer heater bowl
6. Tube with nozzle for supplying water to the heater
7. Decorative grill
8. Protection screen
9. Terminal module
10. Thermal switch
11. Glass cladding
12. Brick cladding
13. Stone cladding
14. Professional power control unit
15. Power control unit with Bluetooth
16. Wire, air temperature sensor

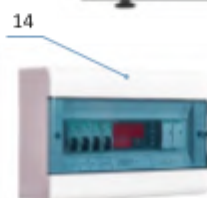
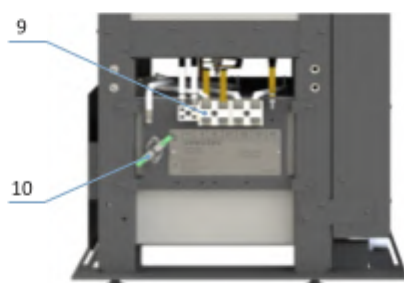
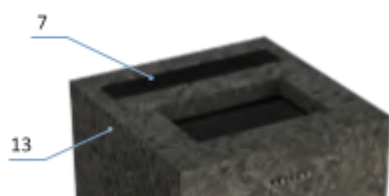
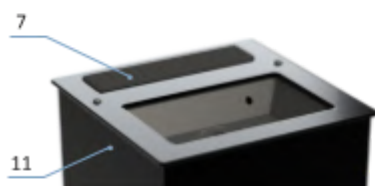
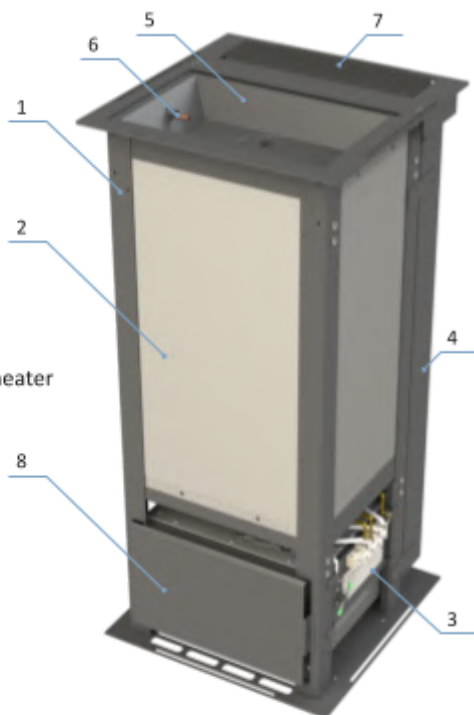

## APPENDIX 2.

### Connecting the electric heater

Connect the electric heater to the control unit in line with the connection diagram (Appendix 4, 5). Use crimp lugs when connecting power cables to ensure reliable contact.

The wires must be connected to the heater via dedicated inlet opening in the cladding on the convection channel side. The wires are routed under the convection heater and then reach the terminal module.

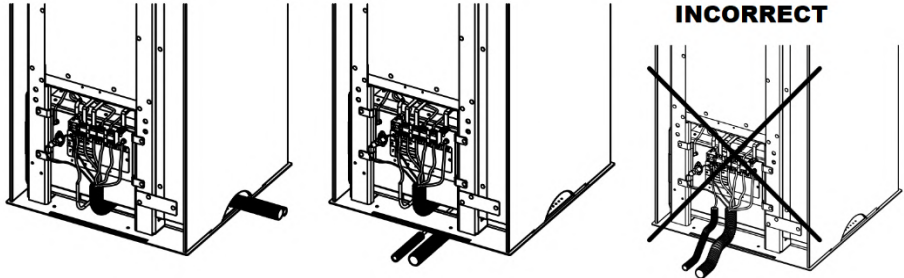

When using a shielded compensating cable of the closed heater sensor, lay it in a corrugated PVC tube, 16 mm in diameter, and route it from the control unit to the cladding, then insulate the wires with a heat shrink tubing and place it inside the casing, routing it through to the terminal module. Place the remaining wires in a metal hose with a diameter of 25 mm.

**WARNING!** In case a compensating cable shield accidentally touches any grounded element, including non-painted parts of the heater, or the foil cladding of the steam room, if the wire is in a corrugated shield and the shield touches a grounded element, an error message "-----" may appear on the screen of the Bluetooth control unit. Important: the error may occur when restarting after shutdown. Therefore, wire insulation inside the heater casing is required.

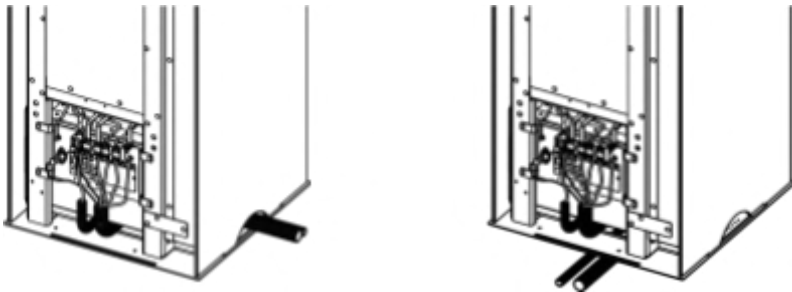

When using a non-shielded compensating cable of the closed heater sensor, lay it in a 16 mm metal hose and the remaining wires in a 25 mm metal hose, and route it from the control unit to the electric heater.

### Closed heater sensor

Connect the closed heater sensor to the terminal module using a thermoelectric (compensating) cable (part of the supply scope of the control unit). Strip the cable cores, install them into the terminal and tighten the lower screw of the terminal module to an average torque value.



The thermoelectric cable implies connection in full accordance with correct polarity. In order to define the polarity, a magnet is to be taken: the core drawn by the magnet needs to be connected to the negative terminal; the core not drawn needs to be connected to the positive terminal.

Note: in order to check if the connection is done correctly, turn on the control unit and check if the current temperature readings are seen on the lower viewscreen. In case of incorrect connection, the viewscreen will show "-----", or the heater readings will decrease instead of increasing, as the heating progresses.

In case of connecting W30 or W40 heaters, both wires of the closed heater cable need to be put into the steel corrugated shield either jointly or separately, however on a mandatory basis separated from all other wires.

**IMPORTANT!!! The thermoelectric cable must in no case be extended by or connected with a different type of cable. If the length of the cable supplied with the device is not sufficient, you will need to purchase the required cable length of the same type.**

The closed heater sensor is placed in a tubular shell in the bottom part of the heater, and moves loosely inside it.

Note: during transportation, the sensor may hit the blanked end of the shell, causing the sensor short-circuiting against the casing, while the control unit screen will read "-----". In order to define the short-circuiting, check the resistance between the sensor contacts and the electric heater casing at the earthing contact. In case of short-circuiting, lower the closed heater sensor by 8-10 mm. Make a new measurement to ensure that the short-circuiting has been eliminated.

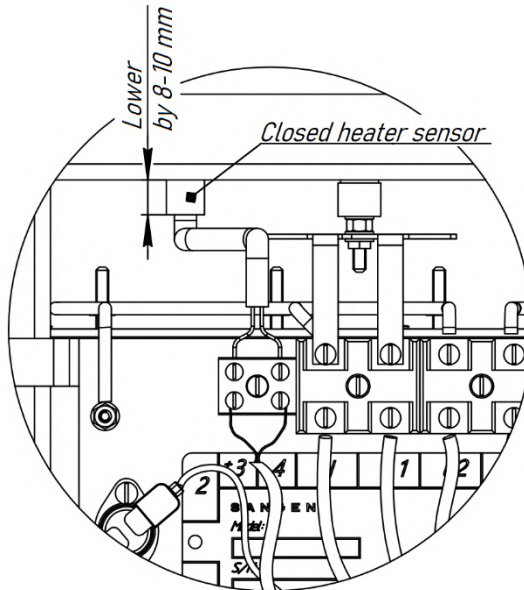

## Air temperature sensor

**WARNING!** The air temperature sensor is part of the control unit supply set. The transmitters that are part of the professional control unit or the Bluetooth control unit, are NOT interchangeable.

The air temperature sensor is to be placed at a height of 1.7-1.8 m above the floor, as far as possible from the ventilation holes and at least 1 m away from the electric heater.

If necessary, the sensor cable can be extended with a copper-core cable with a 0.35-1.5 mm<sup>2</sup> cross-section, by soldering.

Note: for connection to the professional power control unit, use a 2-core cable; short-circuit the sensor end marked with red and solder it to one core, and the end marked with white to another core.

## Cable connection to the terminal module

**Contacts 1, 2** – thermal switch connection

**Contacts 3, 4** – connection of the closed heater sensor

**Contact N** – neutral conductor

**Contacts U1, U2, U3** – connection of the heating parts power supply (U1 - closed heater, U2, U3 – convection heater)

**Contact PE** – protection earthing

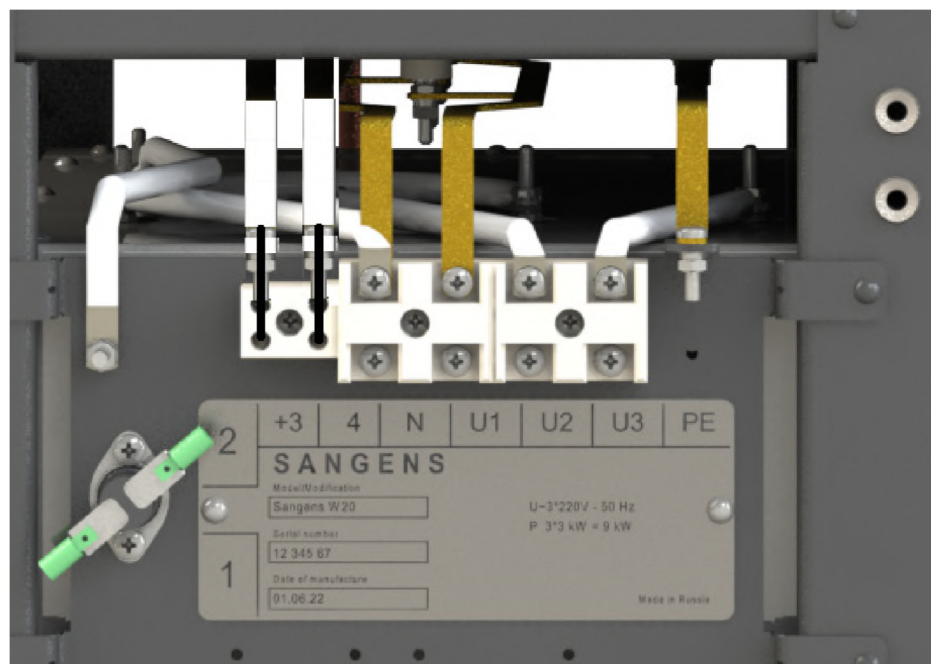



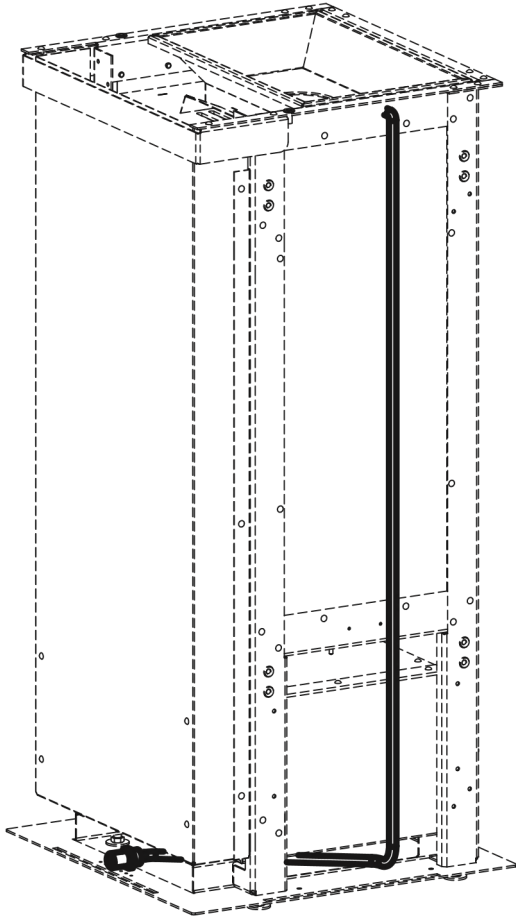

### Automatic watering of stones

Connect the 1/2" tube nozzle for the heater water supply via automatic water supply system (not part of the package to be supplied) to the water main or water tank. Connect the automatic water supply system to the control unit (Automatic water supply system, Appendix 6).

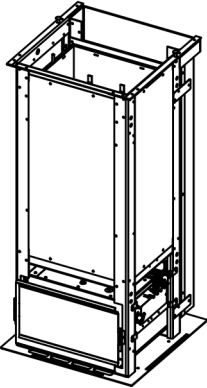

### APPENDIX 3.

#### Installation of component parts of the heater

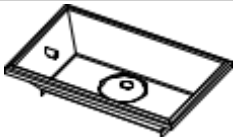
Item No.	Component part	Sangens W12, W20			Sangens W30, W40		
		Brick	Glass	Stone	Brick	Glass	Stone
1	Electric heater casing 	1	1	1	2	2	2
2	Angle bracket type I 	-	-	-	4	4	4
3	Angle bracket type II 	-	-	-	4	4	4
4	Bolt M6*16 complete with nut 	-	-	-	20	20	20
5	Installation frame 	1	1	1	2	2	2
6	Outer heater bowl 	1	1	1	2	2	2



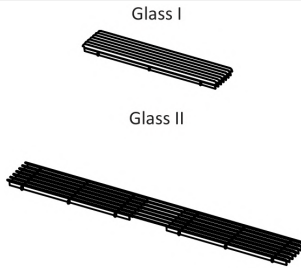
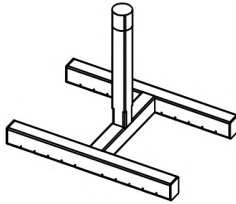
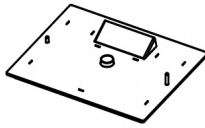
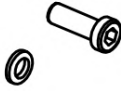

Item No.	Component part	Sangens W12, W20			Sangens W30, W40		
		Brick	Glass	Stone	Brick	Glass	Stone
7	Allen screw, M6*20, complete with fluoroplastic gasket		2			4	
8	Heater cover	1	1	1	2	2	2
9	Steam tube	1	1	1	2	2	2
10	Wing nut	2	2	2	4	4	4
11	Decorative grill		1			1	

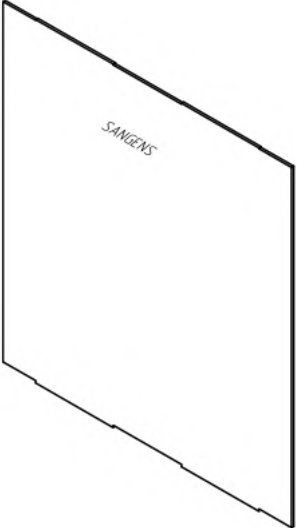

Item No.	Component part	Sangens W12, W20			Sangens W30, W40			
		Brick	Glas s	Ston e	Brick	Glas s	Ston e	
12 Glass cladding								
12.1	Front panel							
		<p>Glass I</p> 	-	1	-	-	1	-
		<p>Glass II</p> 						



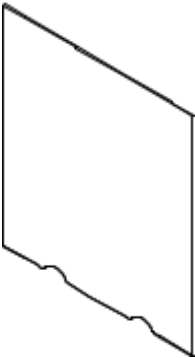



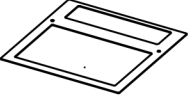
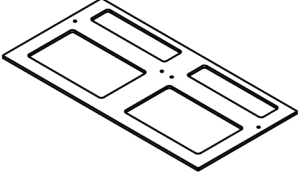
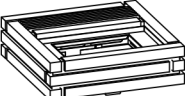
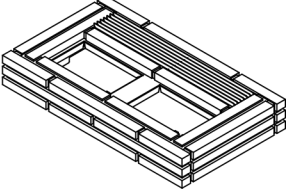

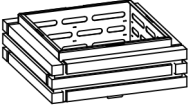
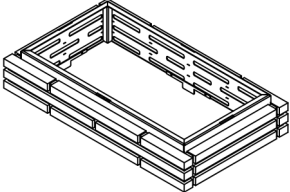
Item No.	Component part	Sangens W12, W20			Sangens W30, W40			
		Brick	Glas s	Ston e	Brick	Glas s	Ston e	
12.2	<b>Rear panel</b>							
		Glass I						
								
		Glass II						
								
12.3	<b>Side panel</b>							
		Glass I	Glass II					
								

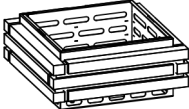
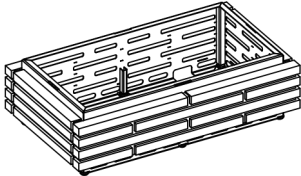

Item No.	Component part		Sangens W12, W20			Sangens W30, W40		
			Brick	Glas	Stone	Brick	Glas	Stone
12.4	<b>Top panel</b>	<p>Glass I</p>  <p>Glass II</p> 	-	1	-	-	1	-
13 Brick cladding								
13.1	<b>Top module</b>	<p>Brick I</p>  <p>Brick II</p> 	1	-	-	1	-	-

13.2	<b>Middle module</b>	<p>Brick I</p>  <p>Brick II</p> 	3	-	-	3	-	-
------	----------------------	----------------------------------------------------------------------------------------------------------------------------------------------------------------------------------------------------	---	---	---	---	---	---

Item No.	Component part	Sangens W12, W20			Sangens W30, W40			
		Brick	Glass	Stone	Brick	Glass	Stone	
13.3	<b>Bottom module</b>	<p>Brick I</p>  <p>Brick II</p> 	1	-	-	1	-	-
13.4	<b>Repair mortar, 0.5 kg</b>		1	-	-	1	-	-
13.5	<b>Silicone sealant</b>		1	-	-	1	-	-

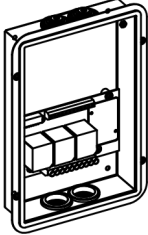
Item No.	Component part	Power control unit with Bluetooth
----------	----------------	-----------------------------------

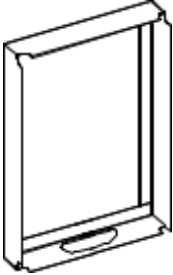
14	Angle bracket for control unit		2
15	Screw M4*20 complete with nut		4
16	Rear part of control unit		1

Item No.	Component part	Power control unit with Bluetooth	
17	Front part of control unit		1
18	Unit casing		1
19	Self-tapping screw 3.5*35		4

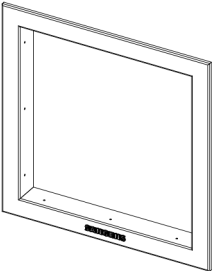
	<b>complete with dowel 6*35</b>		
20	<b>Allen screw, M4*10</b>		4
Item No.	Additional parts		
21	<b>Decorative frame</b>		1

## Laying stones into a closed heater or an outer heater

1. Undo the screws (7) holding the installation frame (5). Remove the installation frame (5), the outer heater bowl (6) and the heater cover (8), unscrew the wing nuts (10), remove the steam tube (9).
2. Place the heat-retaining material into the closed heater up to the level of the angle brackets inside the heater. Install the steam tube (9), put the heater cover (8) on the top for alignment to make sure that the top part of the tube (9) is coaxial with the opening in the heater cover (8), then remove the cover (8). Keep placing the heat-retaining material inside, up to the level of 50-60 mm below the top edge of the heater.
3. Put the heater cover (8) back, then strongly tighten the wing nuts (10).
4. Install the outer heater bowl (6) and the installation frame (5) (if necessary); the bowl (6) must not protrude beyond the installation frame (5).

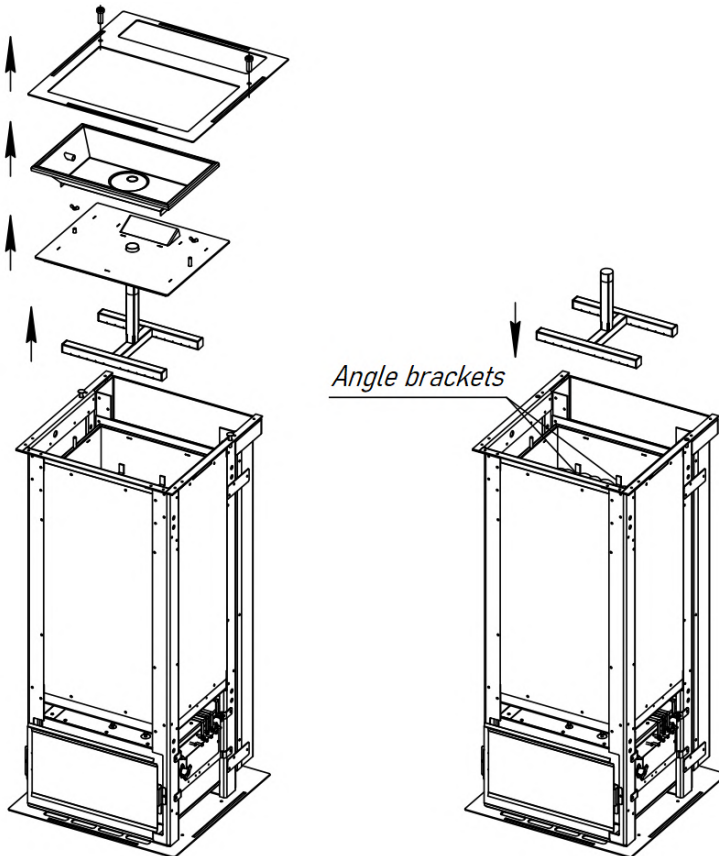

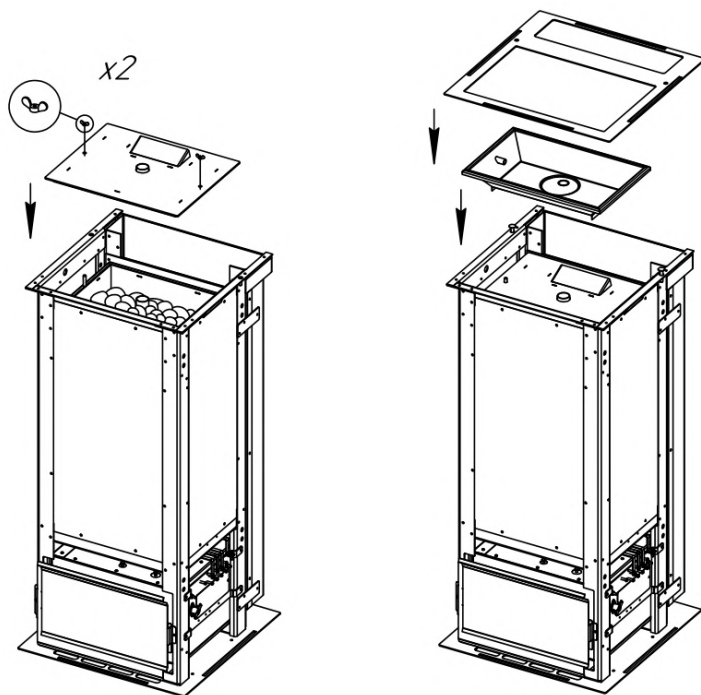

**5.** Having completed the assembly and the installation, put the heat-retaining material into the outer heater bowl (6).

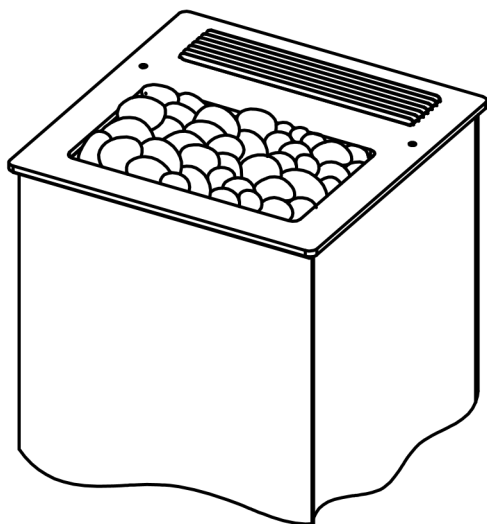



## Assembly of Glass I, Glass II cladding

*Note: two persons working in a coordinated manner are required for correct and safe assembly.*

**WARNING!** Prior to the assembly, inspect the cladding elements, and call SANGENS service if any chipping or cracking is detected.

1. Dismantle the installation frame (5) by undoing the screws (7).
2. Install the rear panel (12.2) into the recesses in the electric heater basement (1). Install the side panels (12.3); note that the side panels (12.3) must not protrude beyond the edges of the rear panel (12.2). Install the front panel (12.1).

### Class I

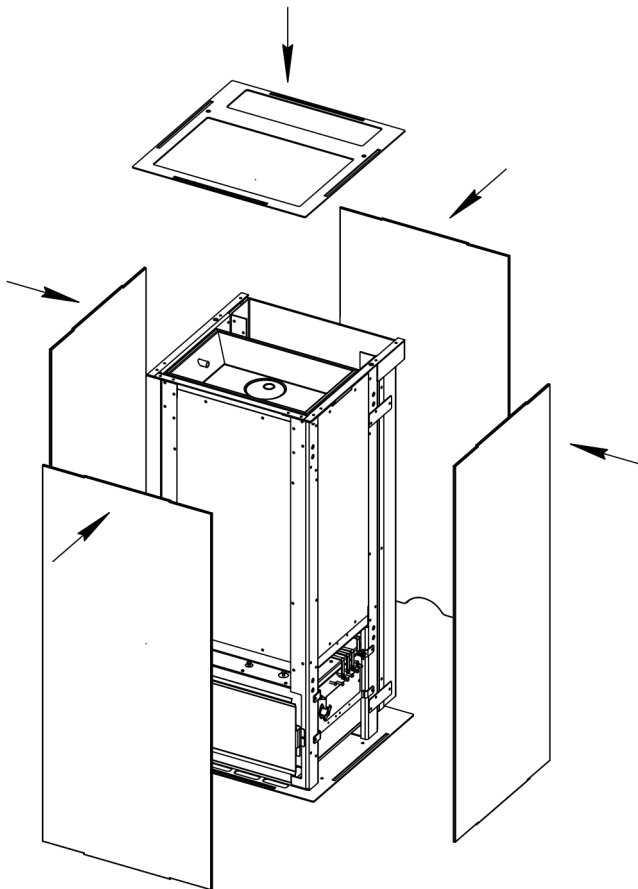

- 3.** Place the installation frame (5) by putting the recesses in the frame against the studs on panels (12.112.3), install the top panel (12.4) and tighten the screws (7), after putting the fluoroplastic gaskets under the screw heads.

*WARNING! Tighten the screws by hand, not using any tool for torquing, to avoid chipping or cracking on the glass.*

- 4.** Install the decorative grill (11).

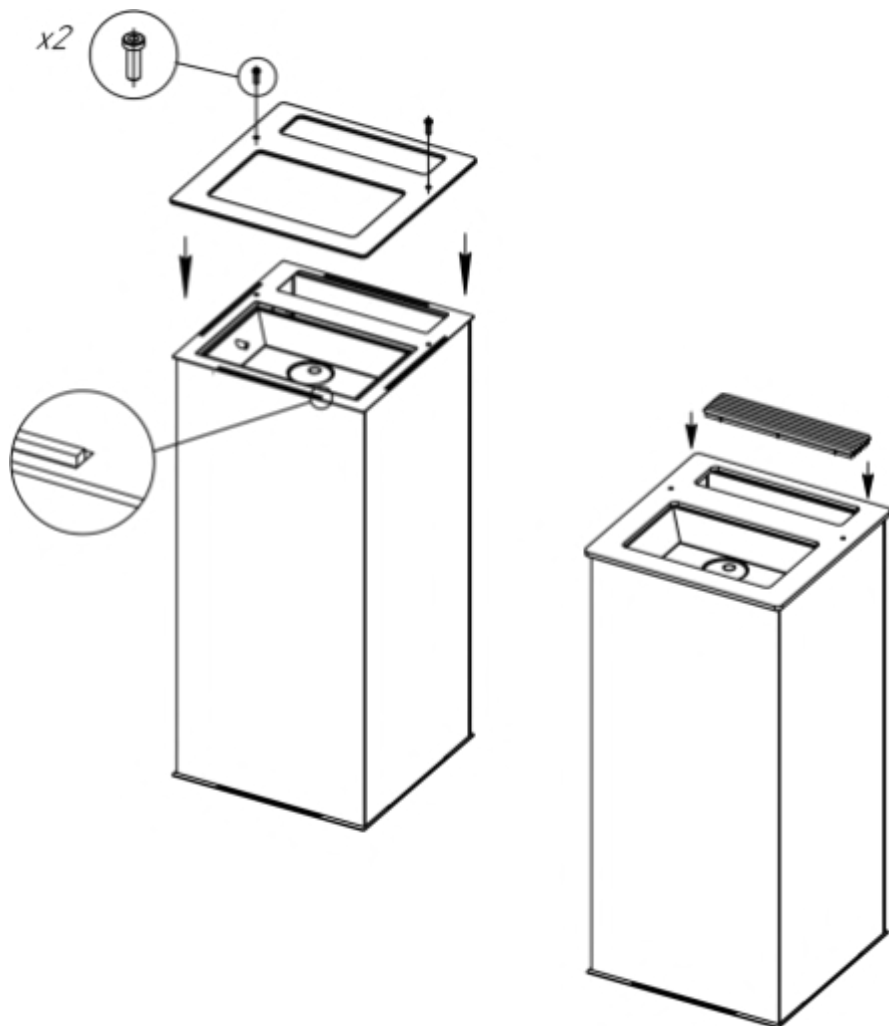

Class II

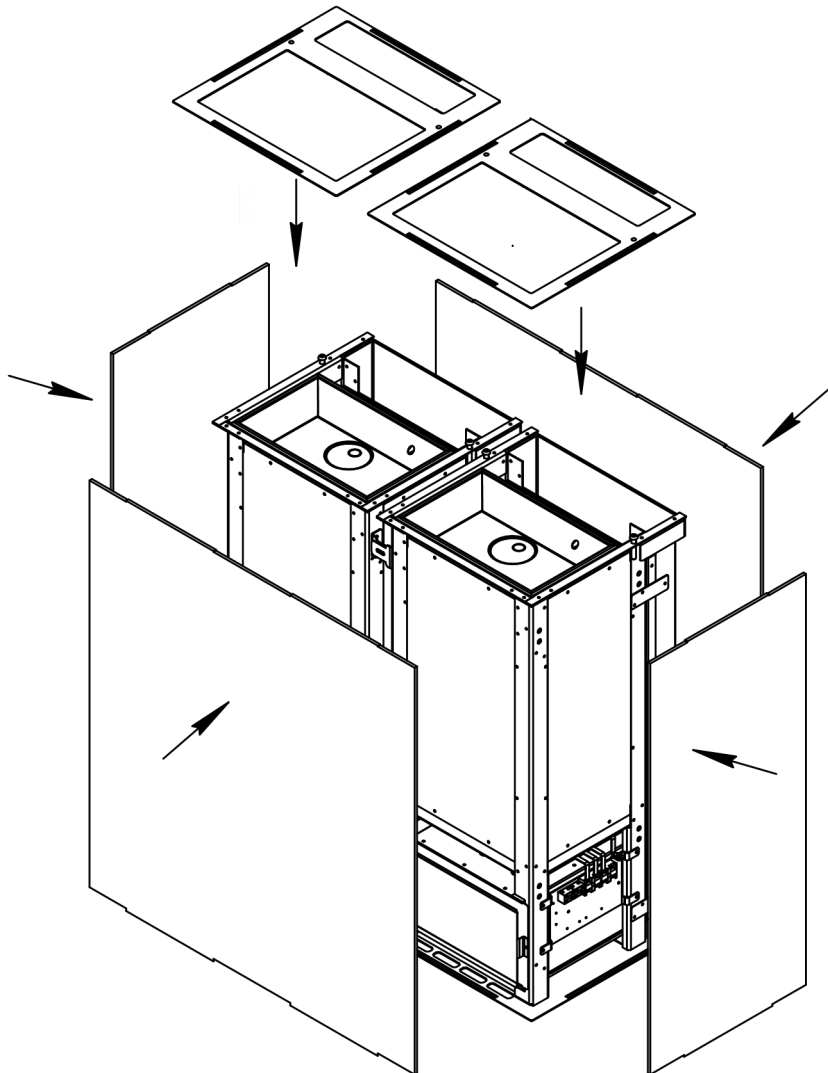

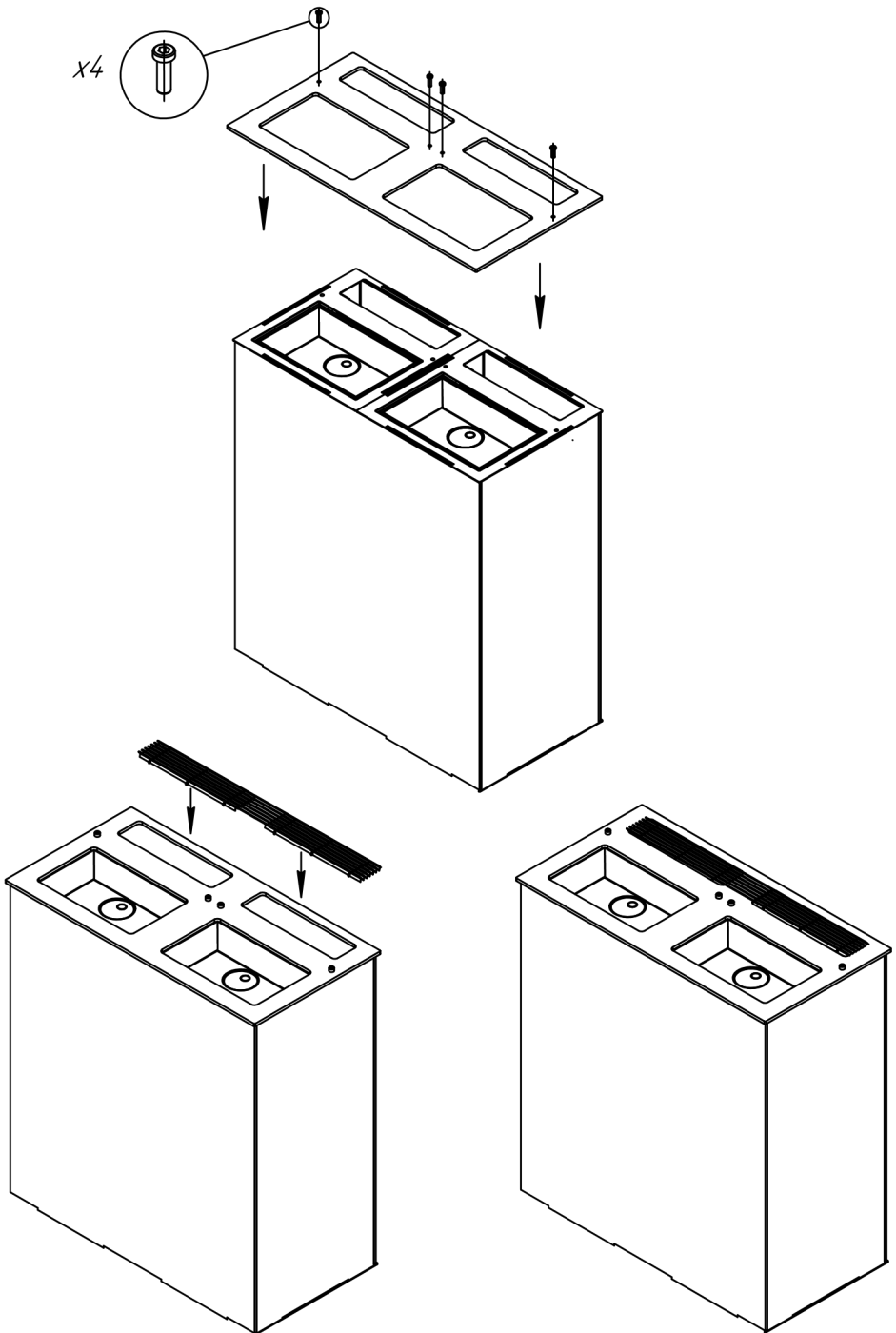

Cladding assembly  
Brick I, Brick II

Brick I

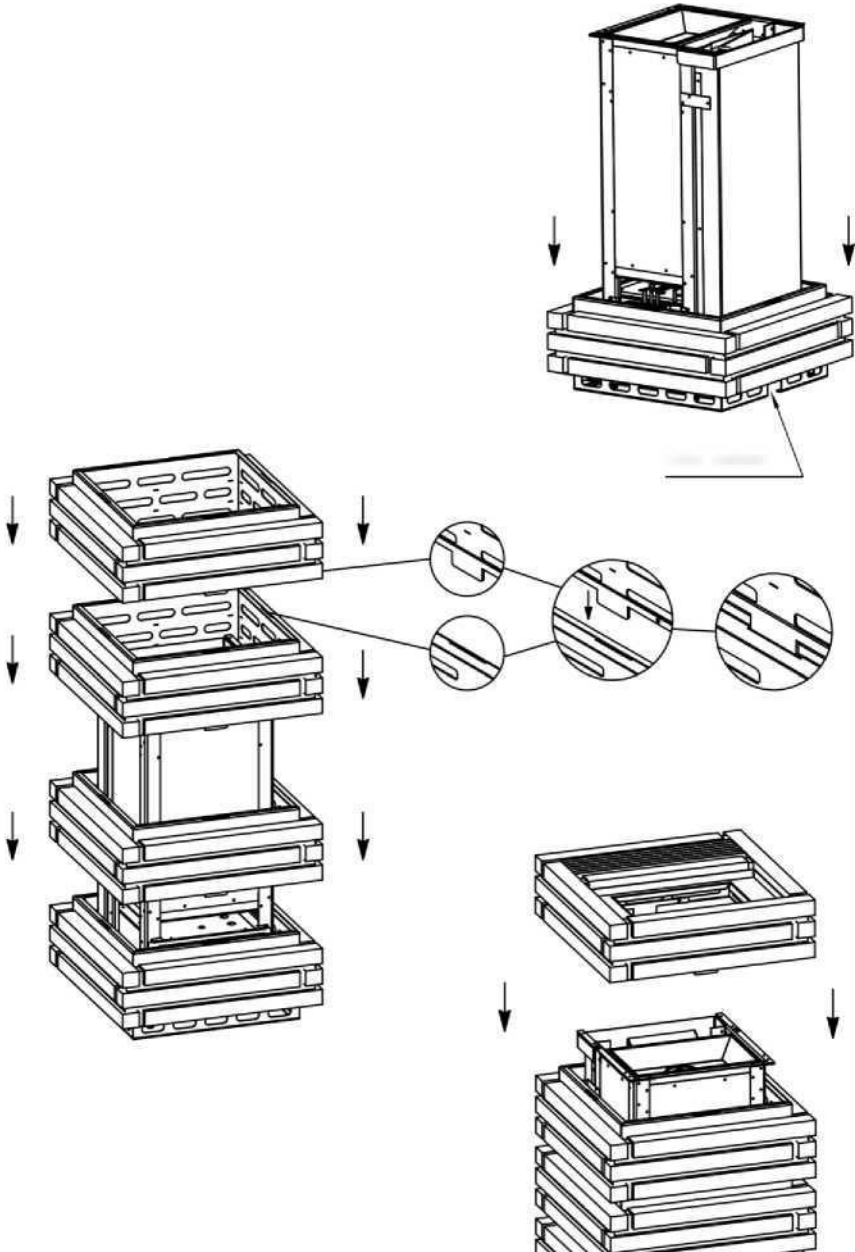

*WARNING! Conduct the work in the most thorough manner, preventing any damage to the cladding.*

*WARNING! As the cladding is made in a long format brick style, the brick color shades may vary.*

**1.** Place the bottom module (13.3) of the cladding in such way that the cable input opening is located against the convection channel.

**2.** Install three modules (13.2), each time placing the relevant four plates on each module into the grooves on the previous module.

*Cable inlet*

**3.** Install the top module (13.1), each time placing the relevant four plates on each module into the grooves on the previous module, with the decorative grill to be placed above the convection channel.

Note: should you have failed to prevent damage to the brick cladding and the brick has fallen down from the brickwork, put some silicone sealant (13.5) on it and put it back on its place, then fill the gaps around the brick with repair mortar (13.4).

Repair mortar preparation method (13.4):

Add the mix (13.4) into the container with pure water (calculated as 40 ml water for every 200 g dry mix) and mix it with a mechanical tool to get a uniform and smooth paste (for about 5 minutes). Give the mix some time to rest (3-5 minutes), then mix it again for 2-3 minutes. The mix will have a rigid-plastic body. Do not add any other aggregates or additives to the mix. Should the mix lose its consistency, reinstate it by mixing, not by adding water. During the drying, the mix must be protected from high humidity, high temperature and direct sunlight.

## Brick II

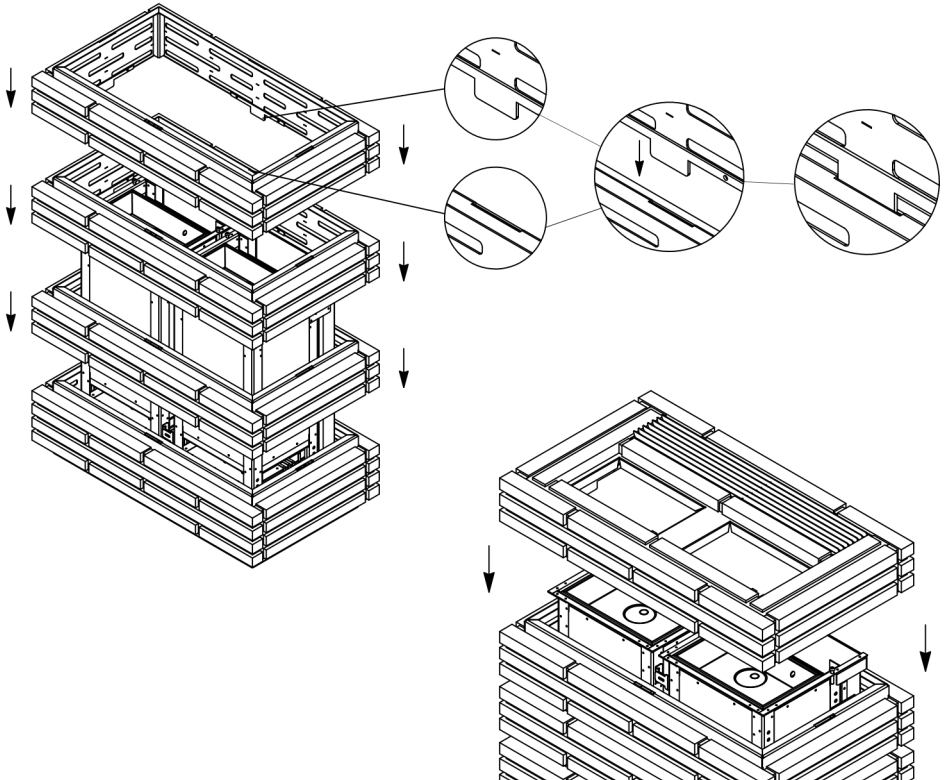
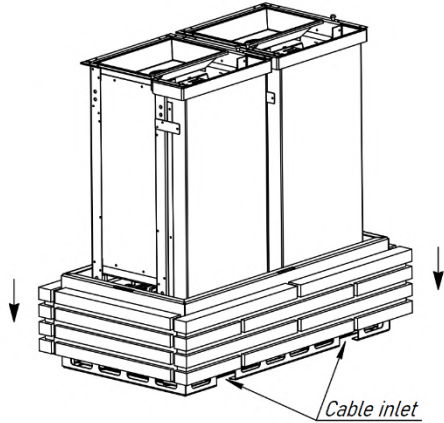

## Assembly of W30B, W40B heater

1. Mount the angle brackets using bolts (4) on the electric heaters (1), as shown on the figure, in such way that bracket type 1 (2) is installed on one heater and bracket type 2 (3) on the other heater.
2. Place the electric heaters (1) on their operational location ensuring alignment between electric brackets (2) and (3) on adjacent heaters, and connect them with bolts (4).

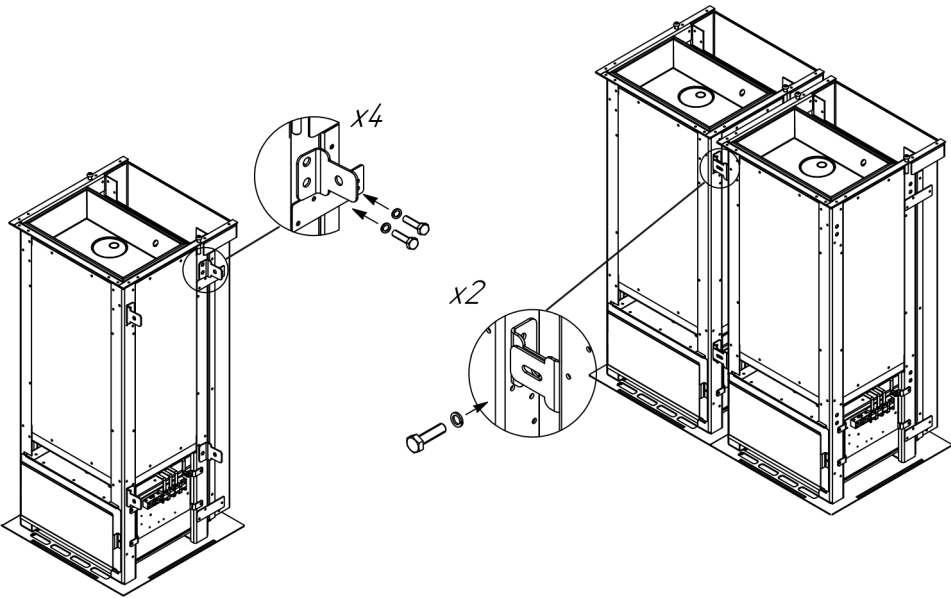

### Decorative frame

1. Before installing the decorative frame (21) into the shelf, cut a 445\*445 mm opening in the shelf.  
*Warning! The location of the opening in the shelf needs to be arranged properly to ensure safety distance from the walls (i. 2.7).*
2. Insert the frame (21) into the opening, fasten it in the end part of the opening using 12 drywall screws, 3.5\*25 mm (not part of supply).



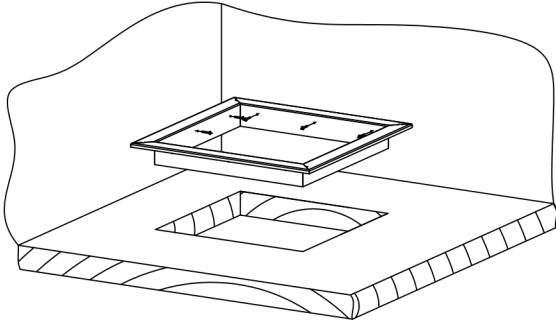

## APPENDIX 4.

### Professional power control unit

1. Connect the control unit to the electric heater in compliance with the wiring diagram for the relevant model and type of power supply.
2. After connecting the power unit to the electric heater check the connections and feed power first to the controller using the 6 A circuit breaker; both sensors will show the temperature. Switch the channels using the keys that have "up" and "down" arrows on them. Next, feed power to the contactors using the 20 A circuit breakers. Make sure that the system is operable, then switch off the power supply and make the final steps of the control unit assembly. Then, start laying stones and installing the cladding.

*WARNING! If contactor 11 has a mode select switch, only AUTO mode operation is allowed.*

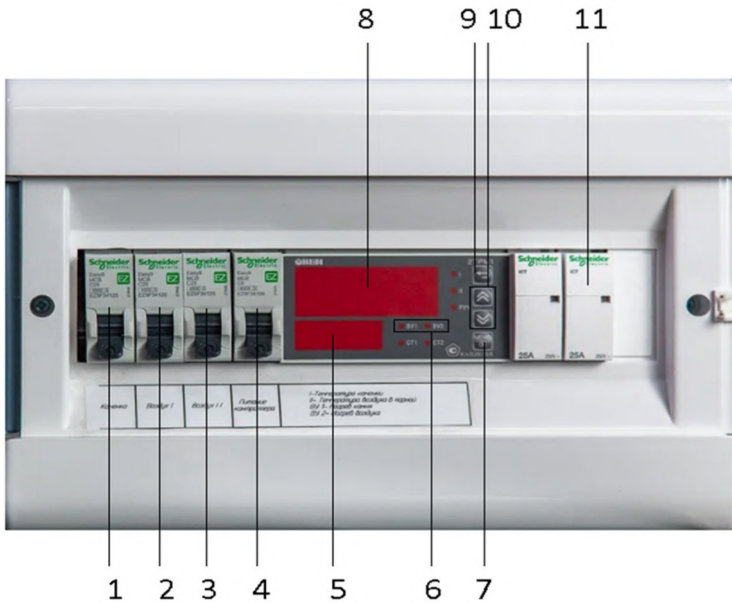

- |    |                                         |     |                            |
|----|-----------------------------------------|-----|----------------------------|
| 1. | Turning on the closed heater            | 7.  | Turning on/ selection menu |
| 2. | and 3. Turning on the convection heater | 8.  | Screen for current values  |
| 4. | Turning on the controller               | 9.  | Return to menu             |
| 5. | Screen for the mode set values          | 10. | Switch to menu             |
| 6. | Heating elements operation indicators   |     |                            |

SANGENS W6-9 professional power control unit

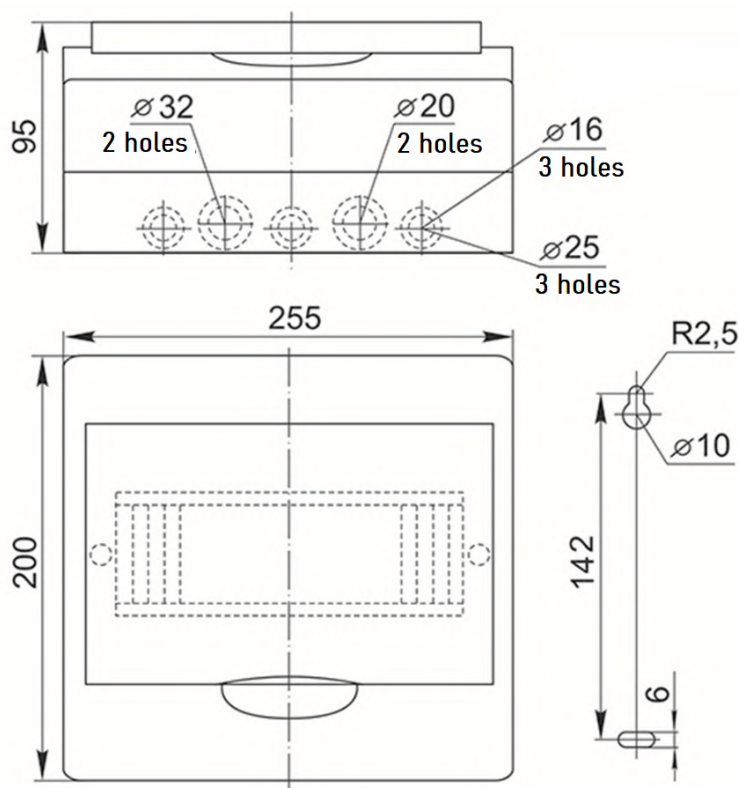

**Electric diagram for connecting the electric heater  
W20, 9 kW, three-phase power supply**

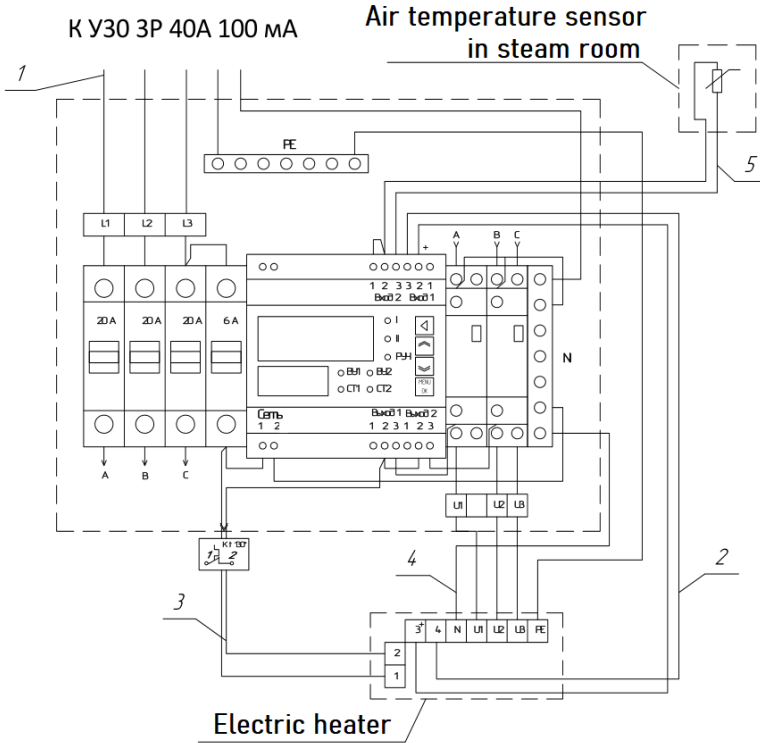

1. Copper-core cable,  $5 \times 2.5 \text{ mm}^2$  cross-section.
2. Compensating cable type K (chromel/alumel)  $2 \times 0.2-0.5 \text{ mm}^2$ , insulation: fiber glass fabric (included in the scope of supply).
3. Thermal switch contacts 1 - 2 - cable with  $1.5 \text{ mm}^2$  cross-section, e.g. 'RKGM' 1.5-660 cable (flexible cable with rubber organosilicon insulation, fiberglass braiding treated with enamel or heat-resistant lacquer).
4. Contacts N - L1 - L2 - L3 - PE - heat-resistant cable,  $2.5 \text{ mm}^2$  cross-section, e.g. 'RKGM' 2.5-660.
5. Air temperature sensor cable (included in the supply scope)

**Electric diagram for connecting the electric heater W12, 6 kW, three-phase power supply**

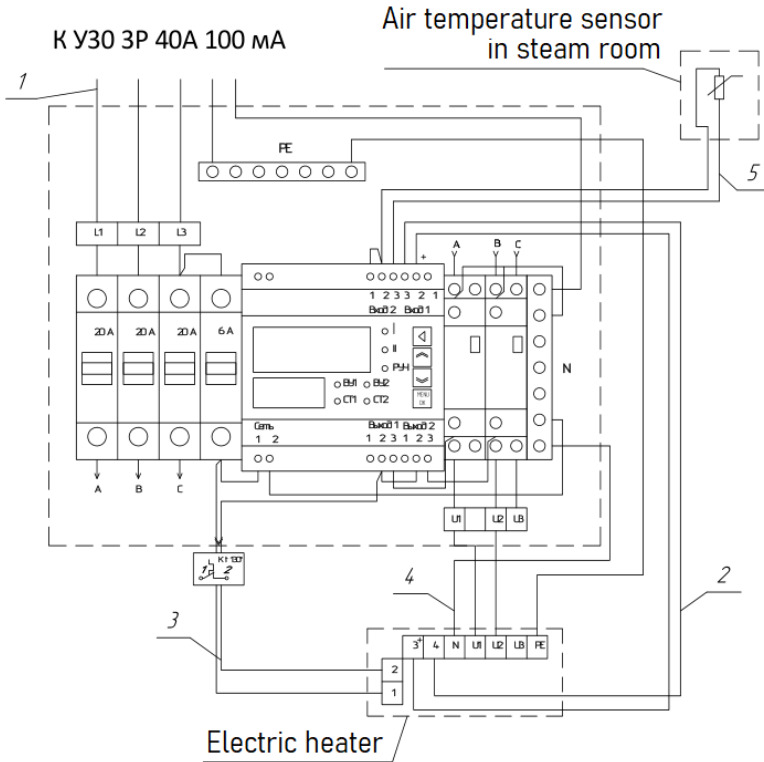

1. Copper-core cable,  $5 \times 2.5 \text{ mm}^2$  cross-section.
2. Compensating cable type K (chromel/alumel)  $2 \times 0.2-0.5 \text{ mm}^2$ , insulation: fiber glass fabric (included in the scope of supply).
3. Thermal switch contacts 1 - 2 - cable with  $1.5 \text{ mm}^2$  cross-section, e.g. 'RKGM' 1.5-660 cable.
4. Contacts N - L1 - L2 - L3 - PE - heat-resistant cable,  $2.5 \text{ mm}^2$  cross-section, e.g. 'RKGM' 2.5-660.
5. Air temperature sensor cable (included in the supply scope).

**Electric diagram for connecting the electric heater  
W12, 6 kW, single-phase power supply**

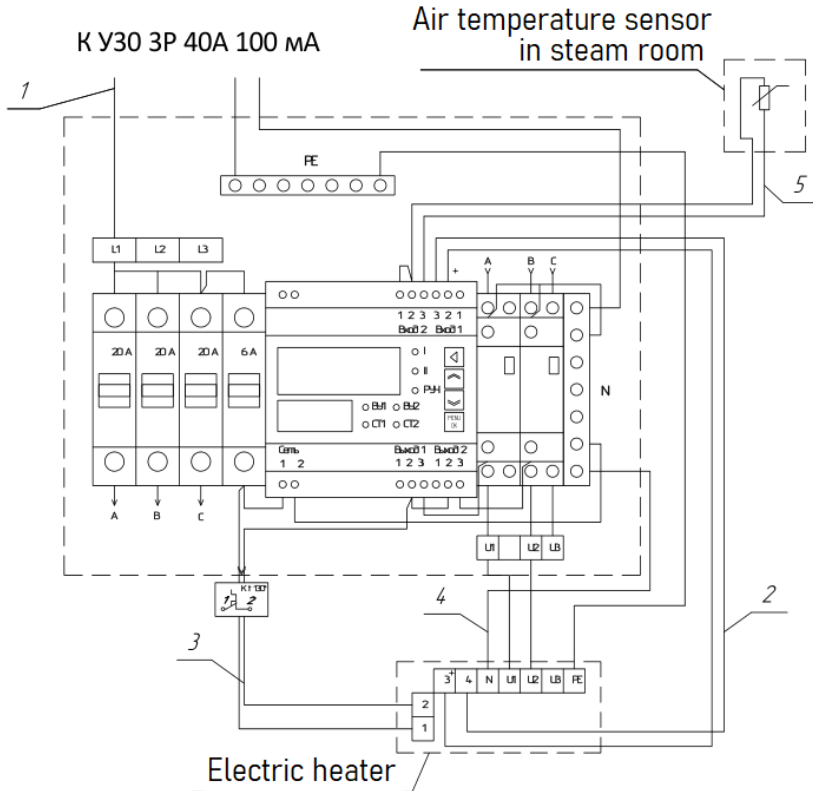

1. Copper-core cable, 3\*4 mm<sup>2</sup> cross-section.
2. Compensating cable type K (chromel/alumel) 2\*0.2-0.5 mm<sup>2</sup>, insulation: fiber glass fabric (included in the scope of supply).
3. Thermal switch contacts 1 - 2 - cable with 1.5 mm<sup>2</sup> cross-section, e.g. 'RKGМ' 1.5-660 cable.
4. Contacts N - L1 - L2 - L3 - PE - heat-resistant cable, 2.5 mm<sup>2</sup> cross-section, e.g. 'RKGМ' 2.5-660.
5. Air temperature sensor cable (included in the supply scope)

# Connection diagrams for Sangens W30B, W40B electric heaters

Датчик температуры  
в парильной комнате

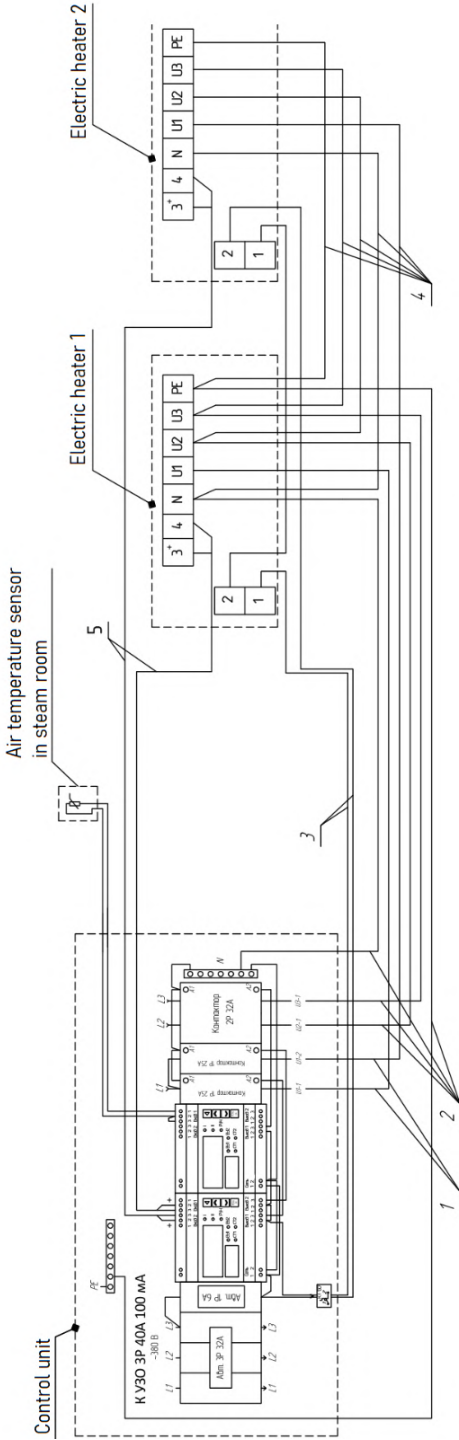

## APPENDIX 5.

### Power control unit with Bluetooth

#### Installing the control unit into a wall recess

1. To install the control unit into a wall recess, fix the angle brackets (14) to the control unit rear part (16) using the fastening element (15) in four points

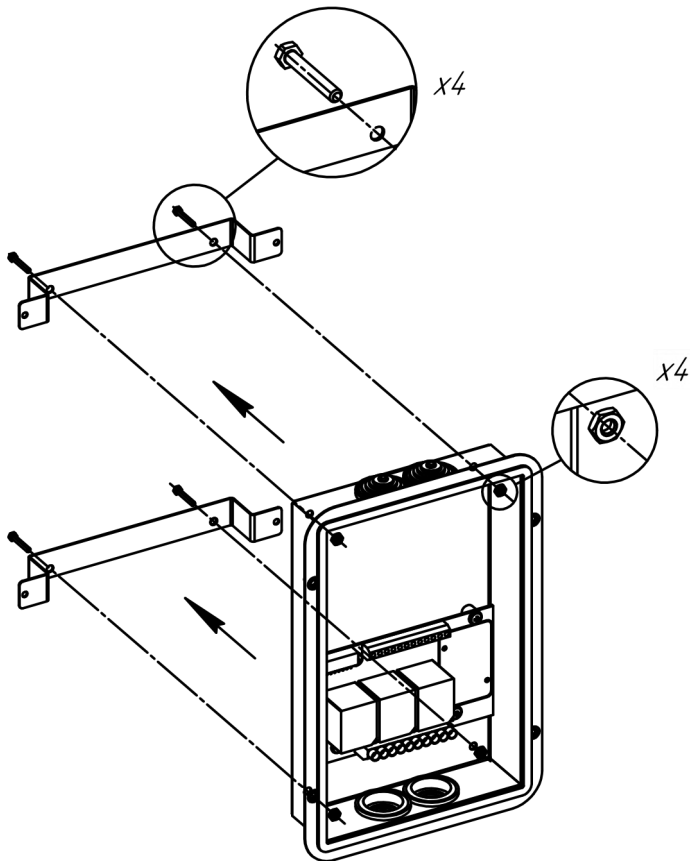

2. Place the rear part of the control unit (16) in the wall recess and fasten the bracket lugs (14) to the wall using self-tapping screws (19).



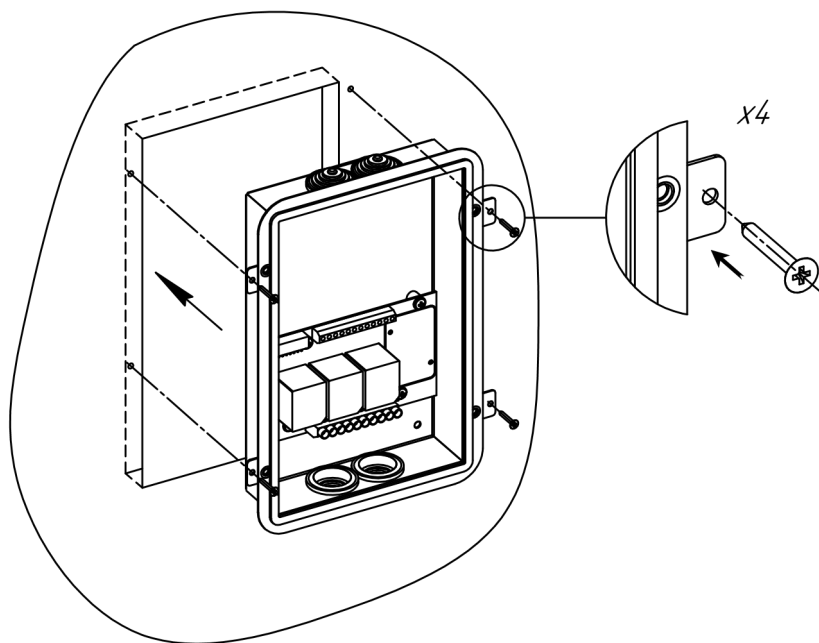

- 3.** Put the front part of the control unit (17) against the rear part (16), plug the flat cable into the relevant slot. Align the openings on the front part (17) and the rear part (16) and fix them together using the fastening element (20).

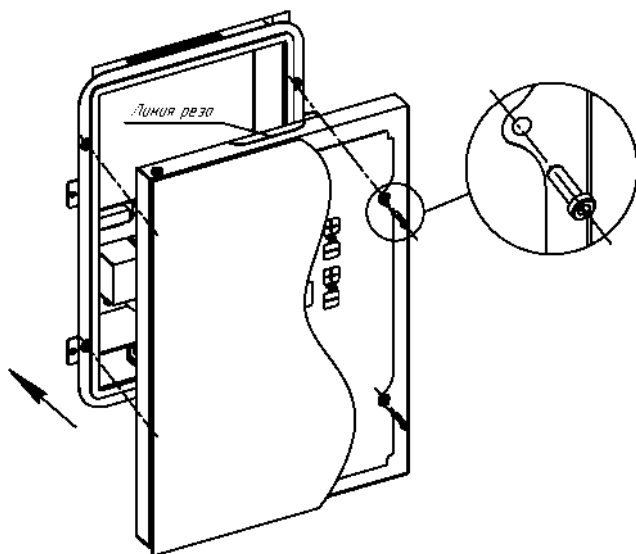

*Note: holes for the cable outlet are located in the top and the bottom sides of the unit front part (17). If necessary, break off the top or the bottom strip along the cut line.*

## Installing the control unit on a wall

1. Prior to the installation, mark the control unit fastening points on the wall, and choose the side of the unit to arrange the cable outlet. Put the rear part of the unit (16) inside the control unit casing (18), having positioned the opening in the casing from the side where the cable outlet is supposed to be, and fasten it on the wall using self-tapping screws (19).

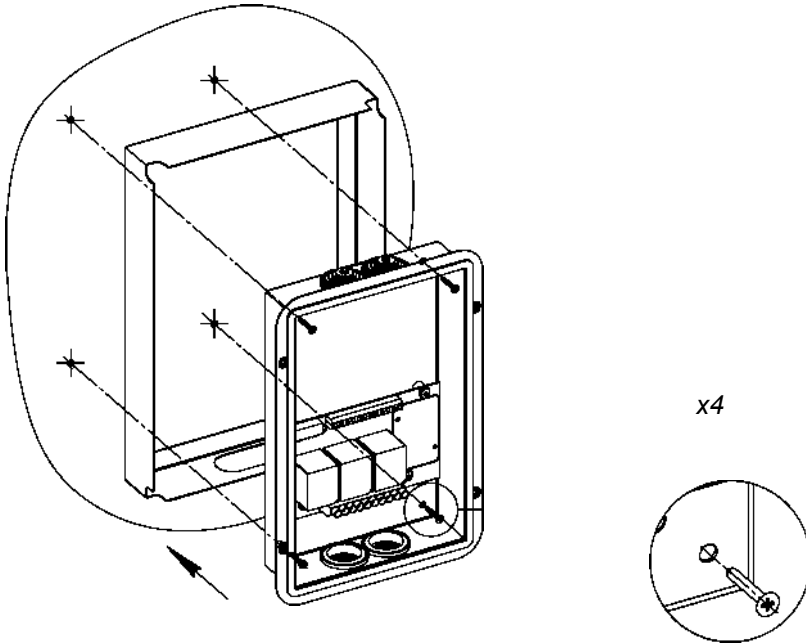

2. Put the front part of the control unit (17) against the rear part (16), plug the flat cable into the relevant slot. Align the openings on the front part (17) and the rear part (16) and fix them together using the fastening element (20).

Note: holes for the cable outlet are located in the top and the bottom sides of the unit front part (17). If necessary, break off the top or the bottom strip along the cut line.

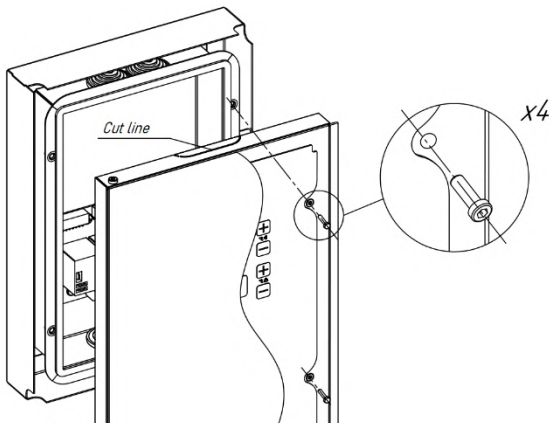

**Power control unit with Bluetooth**

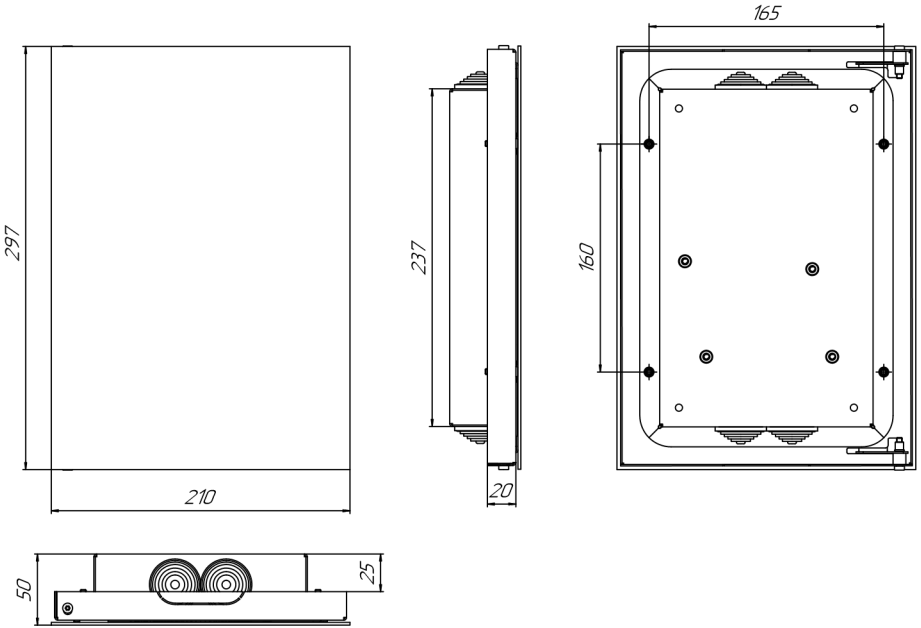

## Indication and operation

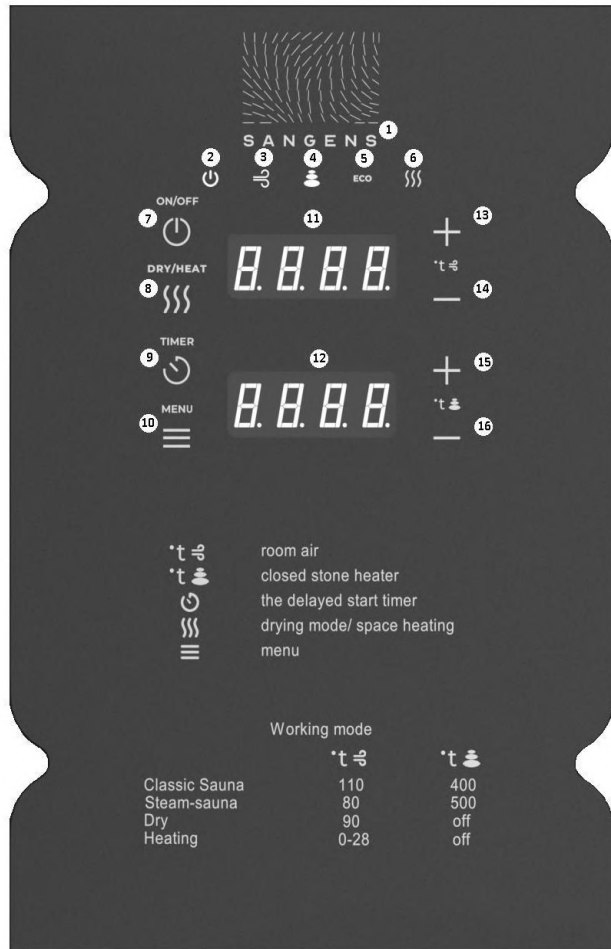

### Indication

- 1 – logo with backlight
- 2 – control panel switch-on indicator
- 3 – air heating circuit switch-on indicator
- 4 – closed heater heating circuit switch-on indicator
- 5 – ECO-mode switch-on indicator
- 6 – drying mode switch-on indicator
- 11 – air temperature indicator
- 12 – stone temperature indicator

### Control keys

- 7 – control panel switch-on
- 8 – drying mode switch-on
- 9 – delayed start timer switch-on
- 10 – settings menu
- 13 – increasing air temperature
- 14 – decreasing air temperature
- 15 – increasing set temperature of the closed heater
- 16 – decreasing set temperature of the closed heater

1. Connect the control unit to the electric heater in compliance with the wiring diagram for the respective heater model and type of power supply.

**WARNING! Remove the diagnostic jumper (FUSE contact) on the board when connecting the control unit with remote access.**

2. To start the electric heater operation, use the keys on the viewscreen to select the required mode (table 2).

The settings menu can be entered by long pressing key No. 10, "MENU".

Switching between DRY and HEAT is performed by long pressing key No. 8.

**WARNING! In case control of the air / heater sensor is lost, the viewscreen shows " - - - - ". To regain control, check connection and operability of the sensor.**

Item	Parameter	Admissible value
t.OFF	Automatic switch-off time*	1-24 hours
PodA	Water supply time period when pressing the key**	0.1-10.0 s
dt.A	Hysteresis of the air heating circuit****	0-5 °C
dt.H	Hysteresis of the heater's heating circuit****	0-90 °C
t.ALL	Control panel service hours counter	-
t.A	Counter of air heating circuit service hours	-
t.H	Service hours counter for the heater's heating circuit	-
tone	Switching on/off the key tones	on / off
LOGO	Switching on/off the logo backlight with the control panel switched off	on / off

\* Recommended value: 6 h. After this time, the electric heater automatically switches completely off.

\*\* Available for electric heaters with automatic water supply.

\*\*\* Recommended value: 2-3 °C.

\*\*\*\* Recommended value: 0-2 °C.

No.	Item	Designation
X1 – slot for power cables. (Inlet for power supply cable. Outlet for cable feeding the electric heater.)		
X1.1	L1	Phase 1 (inlet)
X1.2	U1	Phase 1 (outlet)
X1.3	L2	Phase 2 (inlet)
X1.4	U2	Phase 2 (outlet)
X1.5	L3	Phase 3 (inlet)
X1.6	U3	Phase 3 (outlet)
X1.7	N	Neutral conductor (input/output)
X1.8	N	Neutral conductor (input/output)
X1.9	PE	Earthing (input/output)
X1.10	PE	Earthing (input/output)
X2 – socket for connecting the controller board via flat cable.		
X3 – socket for connecting the power unit to be mounted on the power board.		
X3.1	L1	Phase
X3.2	N/A	Not available
X3.3	N	Neutral wire
X4 – socket for connecting sensors (low voltage).		
X4.1	T	+ (red wire) Air temperature sensor
X4.2	G	- (black wire) Air temperature sensor
X4.3	B	+ Water supply keys
X4.4	G	- Water supply keys
X4.5	+TP1-	+ Sensor t of heater 1
X4.6	+TP1-	- Sensor t of heater 1
X4.7	+TP2-	+ Sensor t of heater 2
X4.8	+TP2-	- Sensor t of heater 2
X4.9	FUSE	Emergency thermal switch. Contact 1
X4.10	FUSE	Emergency thermal switch. Contact 2
X4.11	OUT	Signal 12 V water supply control

X4.12		
X4.13	+	+ Water supply and key backlight power
X4.14	+	Positive (red wire) to the power unit to be installed on the board
X4.15	GND	Negative (black wire) to the power unit to be installed on the board

# Electric diagram for connecting electric heater W12, 6 kW, three-phase power supply

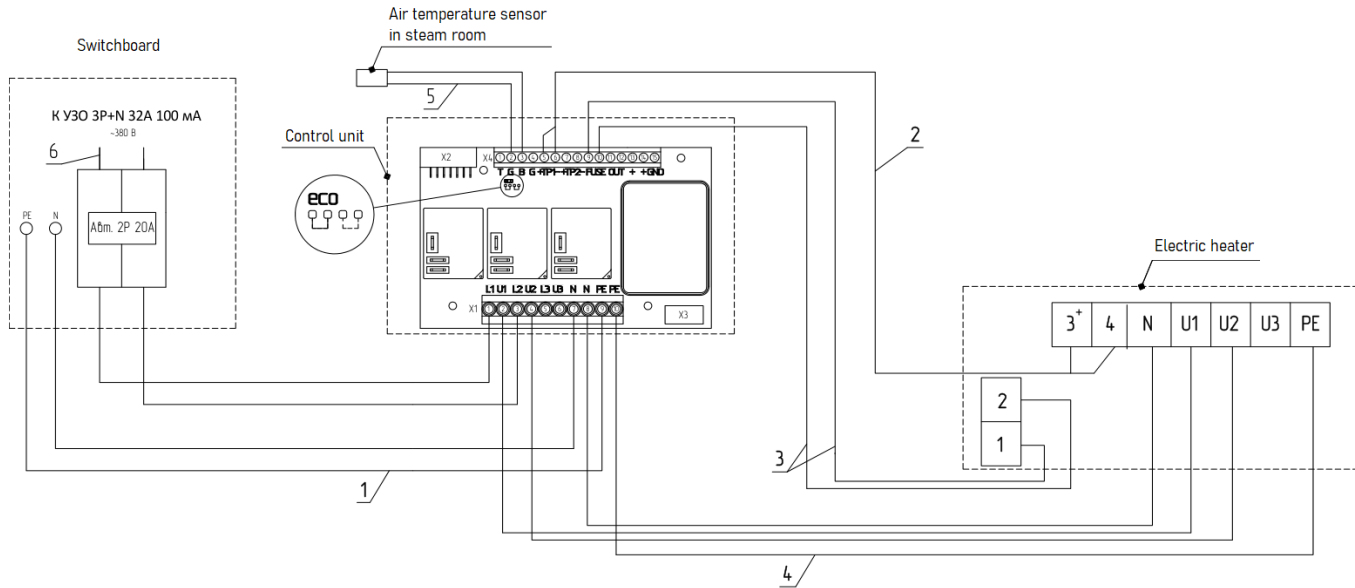

1. Cable, 4\*2.5 mm<sup>2</sup> cross-section
2. Compensating cable type K (chromel/alumel) 2\*0.2-0.5 mm<sup>2</sup>, insulation: fiber glass fabric (included in the scope of supply).
3. Heat-resistant wire, 1.5 mm<sup>2</sup> cross-section, e.g. 'RKGM' 1.5 mm<sup>2</sup>.
4. Heat-resistant wire, 2.5 mm<sup>2</sup> cross-section, e.g. 'RKGM' 2.5 mm<sup>2</sup>.
5. Wire, 5 mm diameter, 2\*0.5 mm<sup>2</sup> cross-section (included in the supply scope).
6. Cable, 4\*2.5 mm<sup>2</sup> cross-section.



## Electric diagram for connecting the electric heater W12, 6 kW, single-phase power supply

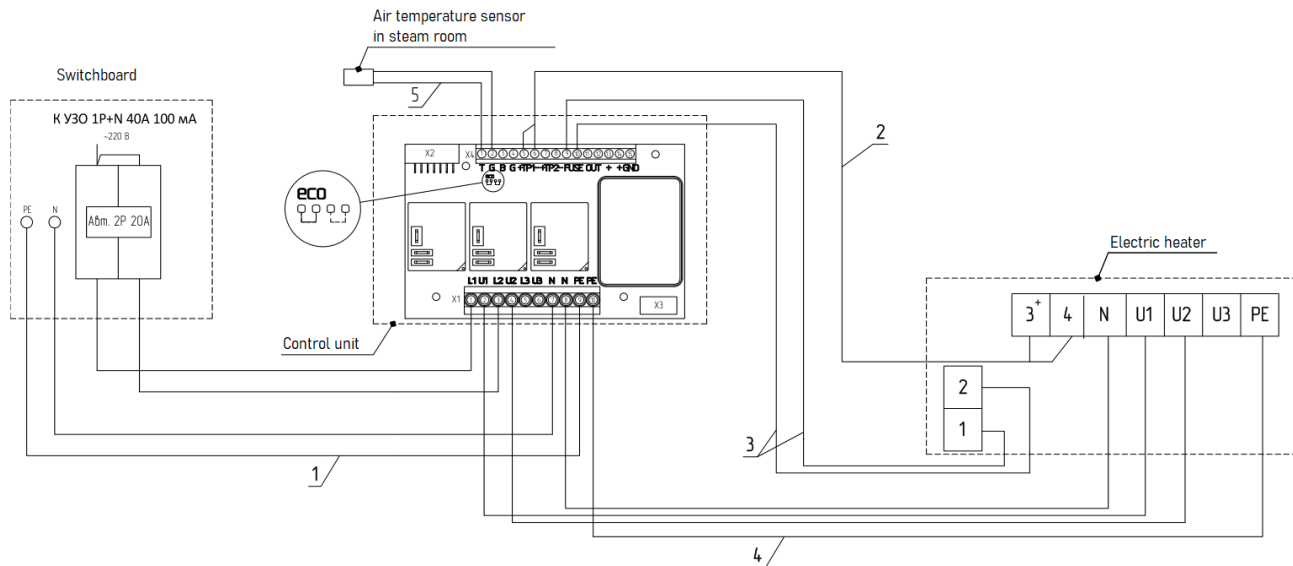

Cable, 3\*4 mm<sup>2</sup> cross-section.

2. Compensating cable type K (chromel/alumel) 2\*0.2-0.5 mm<sup>2</sup>, insulation: fiber glass fabric, braid shielding (included in the scope of supply).

3. Heat-resistant wire, 1.5 mm<sup>2</sup> cross-section, e.g. 'RKGM' 1.5 mm<sup>2</sup>.

4. Heat-resistant wire, 2.5 mm<sup>2</sup> cross-section, e.g. 'RKGM' 2.5 mm<sup>2</sup>.

5. Wire, 5 mm diameter, 2\*0.5 mm<sup>2</sup> cross-section (included in the supply scope).

6. Cable, 4\*2.5 mm<sup>2</sup> cross-section.

# Electric diagram for connecting the electric heater W12, 6 kW, single-phase power supply, ECO mode

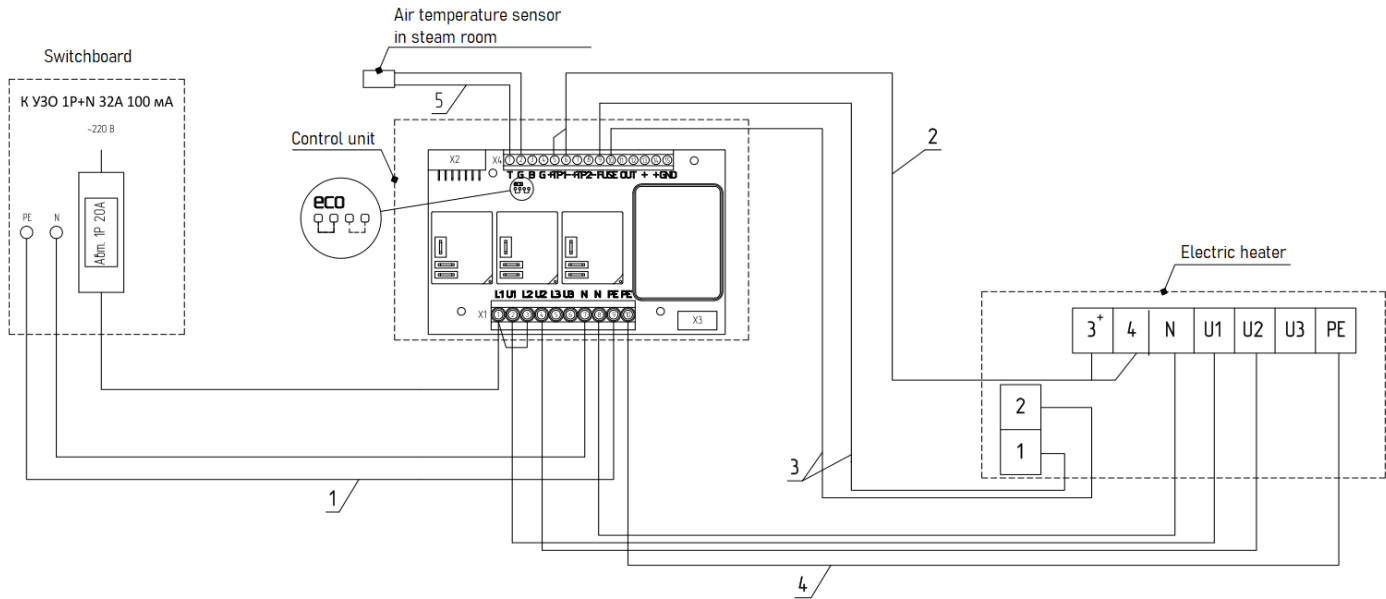

ECO mode: you can switch to the ECO mode when installing the control unit by shifting the peg position on the power board.

1. Cable, 3\*2.5 mm<sup>2</sup> cross-section.
2. 2. Compensating cable type K (chromel/alumel) 2\*0.2-0.5 mm<sup>2</sup>, insulation: fiber glass fabric, braid shielding (included in the scope of supply).
3. Heat-resistant wire, 1.5 mm<sup>2</sup>cross-section, e.g. 'RKGM' 1.5 mm<sup>2</sup>
4. Heat-resistant wire, 2.5 mm<sup>2</sup> cross-section, e.g. 'RKGM' 2.5 mm<sup>2</sup>.
5. Wire, 5 mm diameter, 2\*0.5 mm<sup>2</sup> cross-section (included in the supply scope).
6. Cable, 3\*2.5 mm<sup>2</sup> cross-section.

# Electric diagram for connecting the electric heater W20, 9 kW, three-phase power supply

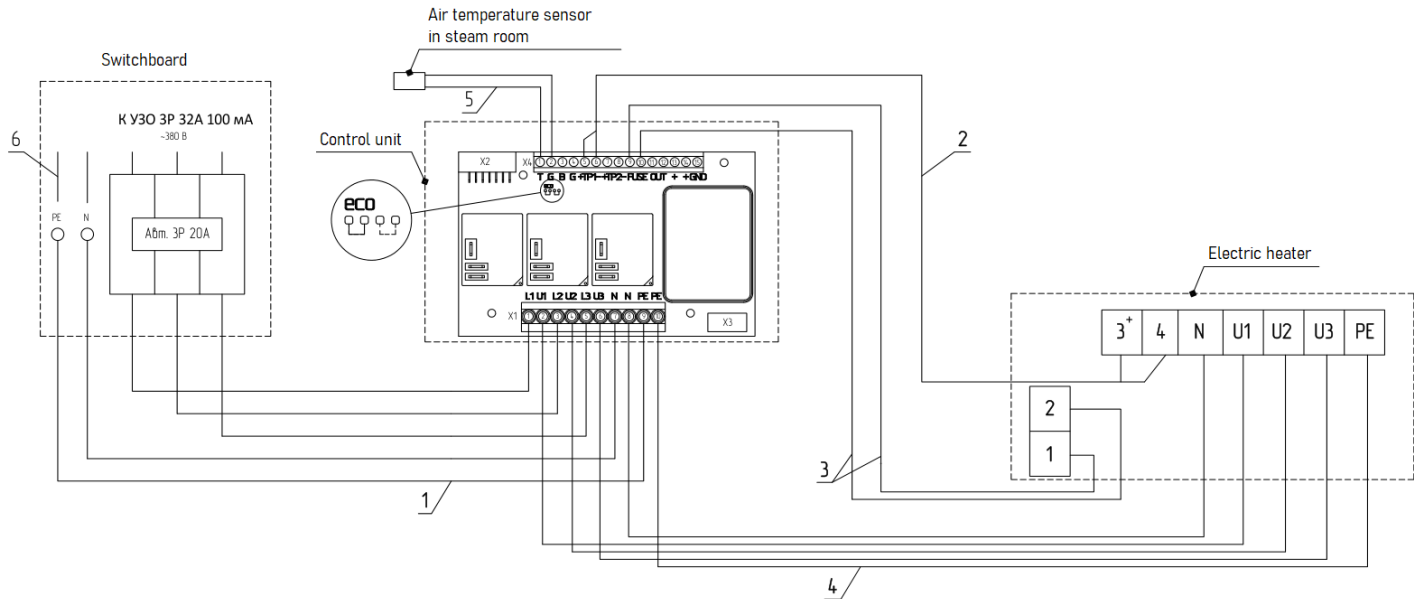

1. Cable, 5\*2.5 mm<sup>2</sup> cross-section.
2. Compensating cable type K (chromel/alumel) 2\*0.2-0.5 mm<sup>2</sup>, insulation: fiber glass fabric, braid shielding (included in the scope of supply).
3. Heat-resistant wire, 1.5 mm<sup>2</sup> cross-section, e.g. 'RKGM' 1.5 mm<sup>2</sup>.
4. Heat-resistant wire, 2.5 mm<sup>2</sup> cross-section, e.g. 'RKGM' 2.5 mm<sup>2</sup>.
5. Wire, 5 mm diameter, 2\*0.5 mm<sup>2</sup> cross-section (included in the supply scope).
6. Cable, 5\*2.5 mm<sup>2</sup> cross-section.

# Connection diagram for Sangens W30B, W40B electric heaters

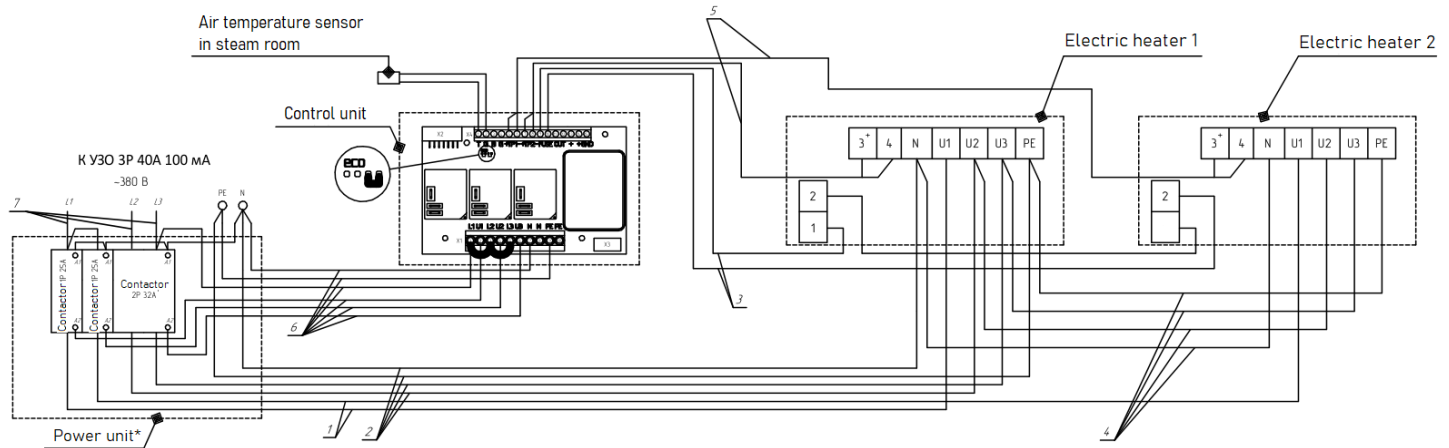

\* Power unit (240\*190\*90 mm) is included in the control unit supply scope

1. Heat-resistant wire, 2.5 mm<sup>2</sup>
2. Heat-resistant wire, 4 mm<sup>2</sup>
3. Heat-resistant wire, 1.5 mm<sup>2</sup>
4. Heat-resistant wire, 2.5 mm<sup>2</sup>
5. Compensating cable 2\*0.5 chromel/alumel, insulation: fiber glass fabric.
6. Cable, 2 pcs., 3\*1.5 mm<sup>2</sup>, vinyl insulation
7. Cable 5\*4 mm<sup>2</sup>

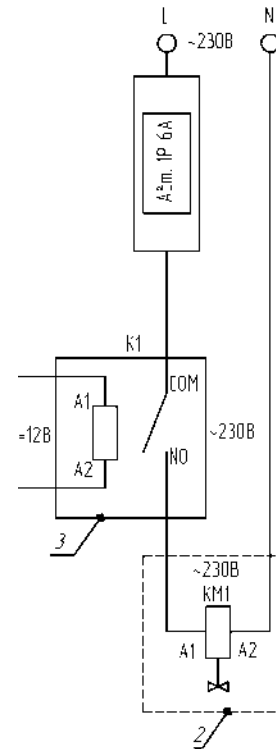
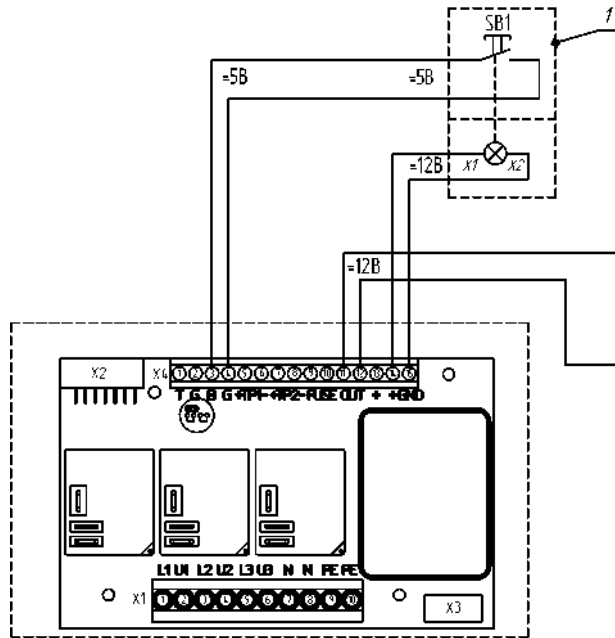

## Automatic water supply system diagram



1. Water supply key, normally open, no fixation, LED backlight, 12 V. IP67 grade.
2. Water supply solenoid switch, normally closed, 220 V control coil. Connection: 1/2", up to 100°C.
3. Auxiliary relay 220 V, normally open contacts. Control coil 12 V.

## APPENDIX 6.

### SANGENS Control Mobile Application

1. In order to connect a mobile device to the control unit, switch on the Bluetooth function, select the relevant device from the list of found devices, e. g. JDY-33-SPP. Enter password to enable the connection, if required: 1234.
2. Open the SANGENS app, press the key  and select the control unit from the list. If the connection to the control unit is correct, the sign  will be backlit.
3. To start the electric heater operation, use the keys on the viewscreen to select the required mode (table 2).
4. The settings menu can be entered by long pressing key No. 10, "MENU".

### Indication and operation

#### Indication

- 1 – panel switch-on indicator
- 2 – air heating circuit switch-on indicator
- 3 – closed heater air heating circuit switch-on indicator
- 4 – ECO mode switch-on indicator
- 5 – drying mode switch-on indicator
- 6 – mobile device pairing indicator

#### Control keys

- 7 – control unit switch-on
- 8 – drying mode switch-on
- 9 – delayed start timer switch-on
- 10 – settings menu
- 11 – increasing air temperature
- 12 – decreasing air temperature
- 13 – increasing set temperature of the closed heater
- 14 – decreasing set temperature of the closed heater

Item	Parameter
t.OFF	Automatic switch-off time*
PodA	Water supply time period when pressing the



dt.A	Hysteresis of the air heating circuit****	0-5 °C
dt.H	Hysteresis of the heater's heating circuit****	0-90 °C
t.ALL	Control panel service hours counter	-
t.A	Counter of air heating circuit service hours	-
t.H	Service hours counter for the heater's heating circuit	-
tone	Switching on/off the key tones	on / off
LOGO	Switching on/off the logo backlight with the control panel switched off	on / off

\* Recommended value: 6 h. After this time, the electric heater automatically switches completely off.

\*\* Available for electric ovens with automatic water supply. \*\*\*

Recommended value: 2-3 °C.

\*\*\*\* Recommended value: 0-2 °C.

**APPENDIX 7. Scope of supply**

Scope of supply	pcs.	Sangens W12, W20			Sangens W30, W40		
		Brick	Glass	Stone	Glass	Brick	Stone
Electric heater casing	pcs.	1	1	1	2	2	2
Decorative grill	pcs.	-	1	-	-	2	-
Glass cladding	pcs.	-	1	-	-	1	-
Stone cladding	pcs.	-	-	1	-	-	1
Brick cladding	pcs.	1	-	-	1	-	-
Repair mortar, 0.5 kg	pcs.	1	-	-	1	-	-
Silicone sealant	pcs.	1	-	-	1	-	-
Control unit	pcs.	1	1	1	1	1	1
The thermoelectric cable	m	5	5	5	10	10	10
Wire, air temperature sensor	m	5	5	5	5	5	5
Installation and operation manual	pcs.	1	1	1	1	1	1









# SANGENS



*Use this QR code to get a video manual for assembly,  
installation and connection to the electric heater*

v.17.04.23