



**ГИДРООТВЕТ**  
доступная гидравлика



## Environmentally Friendly Lubrication System Centralized Lubrication System Factory



<b>Electric Oil Lubrication Pumps</b>	1
ADL Series	2
AMT Series	11
Others	19
<b>Electric Grease Lubrication Pumps</b>	25
EGM Series	27
AHGS & AHG Series	31
AGP Series	39
AMG Series	43
Others	50
<b>Minimum Quantity Lubrication</b>	56
<b>Single-point Lubricators</b>	60
<b>Manual Lubrication Pumps</b>	62
Oil Hand Pumps	63
Grease Hand Pumps	64
<b>Pneumatic Lubrication Pumps</b>	68
Oil-mist Pumps	68
Grease Injectors	72
<b>Lubricant Metering Devices</b>	75
Oil Metering Devices	76
Grease Metering Devices	83
<b>Accessories</b>	108
Cartridge, Filter, Oil cup, Tube	108
Tubing fittings	119
Others	131

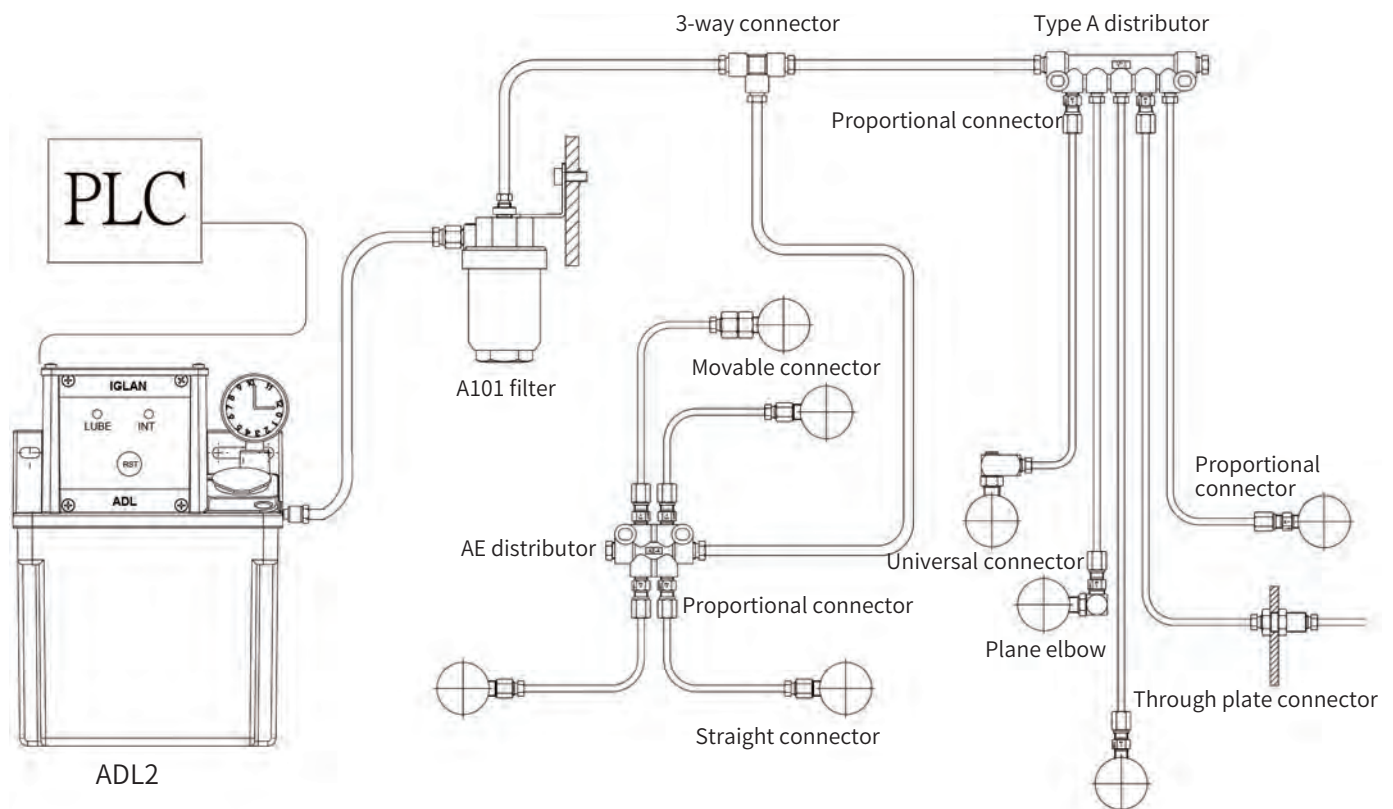

## Principle

The damping resistance lubrication system is a low-pressure lubrication system, which consists of a lubrication pump, distribution, pipe fittings and a controller. The working pressure of the system is 0.17~2.5MPa, the oil viscosity range is 20~750mm<sup>2</sup>/s, and it can lubricate 1-50 points. .

- 1) Periodic lubrication system: The pump that works periodically distributes proportional oil to each lubrication point through metering parts CPV, CPB, SS.
- 2) Continuous lubrication system: The pump that works continuously distributes the proportional oil to each lubrication point through the control part.

## Feature

1. Compact structure, economical, easy to operate and maintain;
2. The oil supply amount of the lubricating point is controlled by the proportional joint or the control part, and the oil is supplied proportionally;
3. It is more convenient to increase or decrease the lubrication point;
4. The sealing design can effectively prevent leakage at the joint.

## Products

Pump units: ADL1, ADL2, AMT1, AMT2, SMA lubrication pump.

Distributors: CPV, CPB, SS, B type.

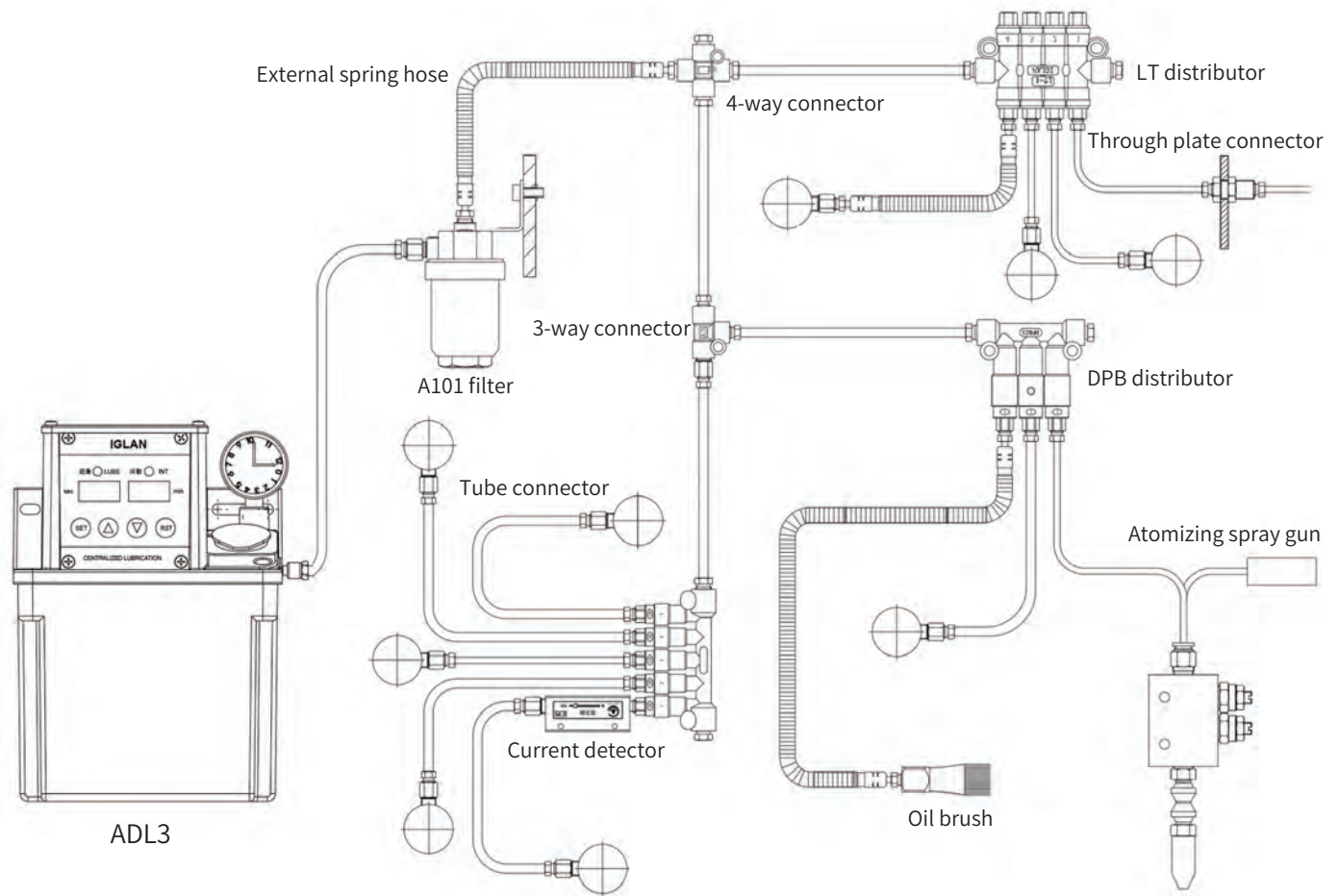

## Principle

The pressure relief oil lubrication system is a periodic lubrication system that can precisely lubricate the lubrication points as needed, with an error rate of about 5%. The oil supply is controlled by the distributor, the minimum oil supply is 0.03mL/cyc, and the maximum is 0.5mL/cyc. The working pressure of the system is 1.5~2.0MPa, the oil viscosity range is 10~2000mm/s, the filtration precision is 25~40 $\mu$ , and 1~50 points can be lubricated.

System principle: The pump outputs pressure oil. The oil chamber of the distributor stores oil (unloading type). When the system pressure rises to 1.2~1.7MPa, the pressure switch will work. The pump stops, the unloading valve works, the oil pressure in the line drops below 0.2MPa, and the distributor discharges oil to complete a cycle. If a pressurized distributor is used, the distributor discharges oil when the pump outputs pressurized oil.

## Feature

1. The oil supply is accurate. If the oil supply needs to be increased, the number of lubrication times can be increased or the volumetric distributor can be selected.
2. The system pressure can be detected. It is convenient to add or reduce lubrication points.

## Products

Pump units: ADL3, ADL4, AMT3, AMT4 type lubrication pump.

Distributors: LT, DPB, MO type.

## ADL1 Resistance Type with Controller



Ordercode **ADL-1-2-0-A-S**

1	Resistance type with controller		S	LUBE(sec); INT(sec)
2	2L reservoir		M	LUBE(sec); INT(min)
3	3L reservoir		H	LUBE(sec); INT(hour)
4	4L reservoir		N	LUBE(sec); INT(time)
0	No pressure switch		A	110 VAC
1	Pressure switch N.C.		B	220 VDC

## Feature

- The system can be set to two action modes:
  - Lubrication: The lubrication time is executed when the machine is turned on.
  - Memory: Power off and on again will continue to execute the unfinished interval time.
- The lubrication time and interval time can be adjusted and locked.
- Equipped with liquid level switch and pressure switch (normally closed, optional). When the oil quantity or pressure is insufficient, the buzzer will give an alarm and output an abnormal signal.
  - Insufficient pressure displays Erp.
  - Insufficient liquid level displays Ero.
- LUB lubrication time: 1-999 seconds, INT intermittent time: 1-999 minutes (second/hour/time), can be customized.
- The panel indicator light can display the lubrication and interval status of the pump.
- "RST" key, forcibly lubricate or eliminate abnormal alarm signal.
- Each lubrication time is less than 2 minutes, and the interval time should be more than 5 times the lubrication time.
- The motor is equipped with an overheat protector to prevent the motor from being overheated and overloaded.
- There is no pressure relief device in the resistance system, and it needs to be used with a proportional joint distributor.
- There is an overflow valve to prevent the pump from overloading and the pipeline pressure being too high.
- Oil viscosity 32-68cSt@40°C.

## Specification

Item Model	Motor Voltage (V)	Motor Power (W)	Lube Time (S)	Interval Time (M)	Working Pressure (MPa)	Max. Pressure (MPa)	Discharge (mL/min)	Outlet Diameter	Pressure Switch	Level Switch	Buzzer	Reservoir (L)	Weight (kg)
ADL-1	110 VAC 220 VAC	30	1-999	1-999	1.0	1.5	150	4mm 6mm	Optional	Yes	Yes	2(Resin)	2.7
												3(Resin)	3.6
												4(Resin)	4.2

## ADL1 Dimension

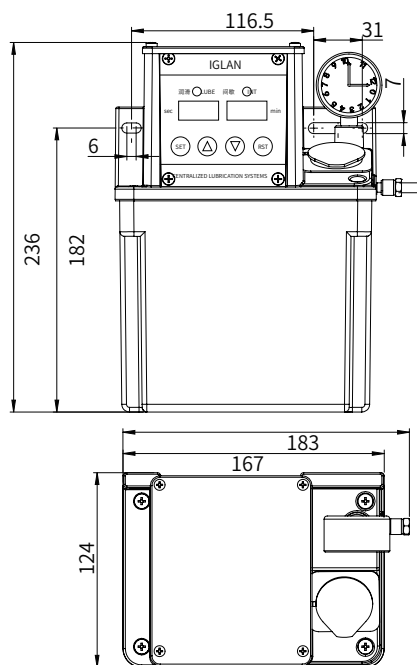

2L reservoir

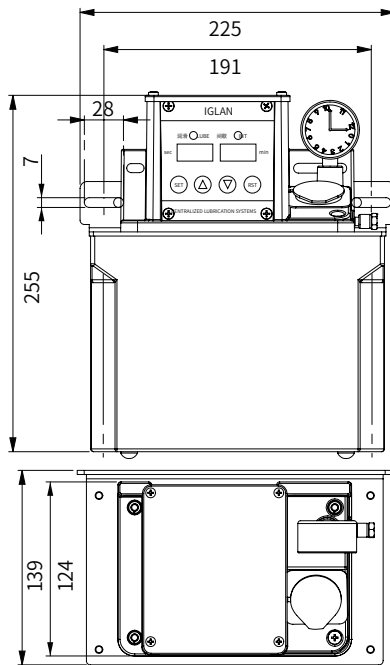

3L reservoir

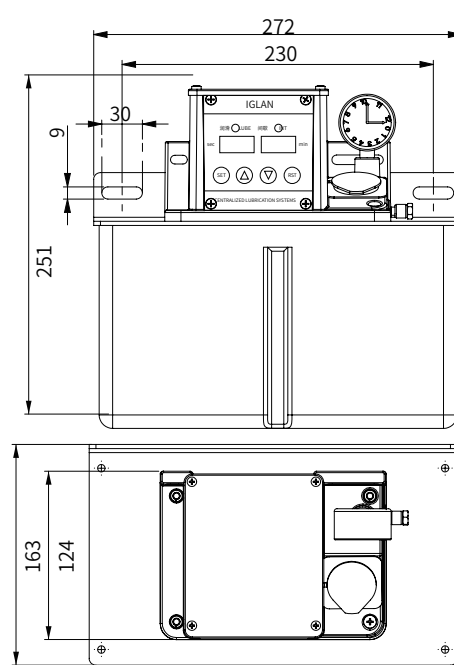

4L reservoir

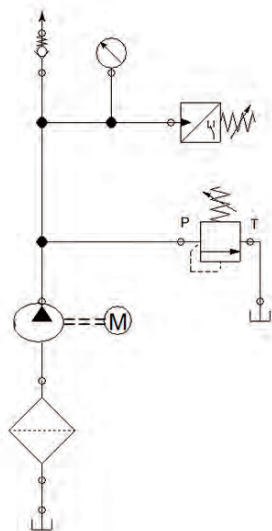

Oil circuit principle

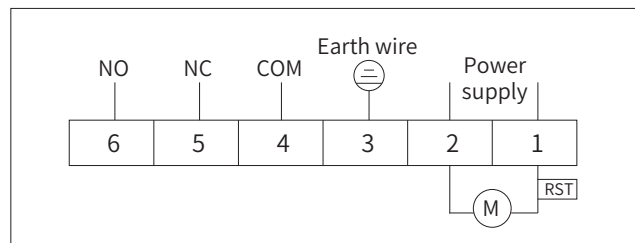

Wiring diagram

## Matching



B type distributor

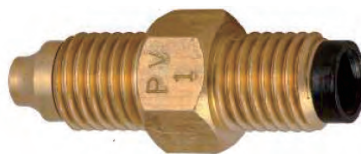

PV proportional connector



PD straight connector



## ADL2 Resistance Type



Ordercode **A D L - 2 - 3 - 0 - B - 1**

2	Resistance type without controller
2	2L reservoir
3	3L reservoir
4	4L reservoir
0	No pressure switch
1	Pressure switch N.C.
2	Pressure switch N.O.
1	Level switch N.C.
2	Level switch N.O.
A	110 VAC
B	220 VAC

## Feature

1. The working time and interval time of the pump are controlled by the host PLC.
2. Equipped with liquid level switch, optional pressure switch, when the oil quantity or pressure is insufficient, the abnormal signal will be output.
3. The panel indicator light can display the lubrication and interval status.
4. The "FEED" key can be forced to lubricate.
5. Single lubrication time should be less than 2 minutes, interval time should be more than 5 times the lubrication time.
6. The motor is equipped with an overheat protector to prevent the motor from being overheated and overloaded.
7. No pressure relief device in the resistance system, which needs to be used with the proportional joint distributor.
8. Equipped with fuse to prevent short circuit and burn out IC board and motor.
9. Equipped with overflow valve, which can protect the pump and pipeline from damage caused by excessive pressure.
10. The oil viscosity range is 32-68cSt@40°C.

## Specification

Item Model	Motor Voltage (V)	Motor Power (W)	Lube Time (S)	Interval Time (M)	Working Pressure (MPa)	Max. Pressure (MPa)	Discharge (mL/min)	Outlet Diameter	Pressure Switch	Level Switch	Buzzer	Reservoir (L)	Weight (kg)
ADL-2	110VAC 220VAC	30	PLC	PLC	1.0	1.5	150	4mm 6mm	Optional	Yes	Yes	2(Resin)	2.7
												3(Resin)	3.6
												4(Resin)	4.2





## ADL3 Pressure-relief Type with Controller



Ordercode **A D L - 3 - 2 - 0 - A - S**

3	Pressure relief type with controller	S	LUBE(sec); INT(sec)
2	2L reservoir	M	LUBE(sec); INT(min)
3	3L reservoir	H	LUBE(sec); INT(hour)
4	4L reservoir	N	LUBE(sec); INT(time)
0	No pressure switch	A	110 VAC
1	Pressure switch N.C.	B	220 VDC

### Feature

- The system can be set to two action modes:
  - Lubrication: The lubrication time is executed when the machine is turned on.
  - Memory: Power off and on again will continue to execute the unfinished interval time.
- The lubrication time and interval time can be adjusted and locked.
- Equipped with liquid level switch and pressure switch (normally closed, optional). When the oil quantity or pressure is insufficient, the buzzer will give an alarm and output an abnormal signal.
  - Insufficient pressure displays Erp.
  - Insufficient liquid level displays Ero.
- LUB lubrication time: 1-999 seconds, INT intermittent time: 1-999 minutes (second/hour/time), can be customized.
- The panel indicator light can display the lubrication and interval status of the pump.
- "RST" key, forcibly lubricate or eliminate abnormal alarm signal.
- Each lubrication time is less than 2 minutes, and the interval time should be more than 5 times the lubrication time.
- The motor is equipped with an overheat protector to prevent the motor from being overheated and overloaded.
- There is a pressure relief device in the system, which needs to be used with LT/DPB/MO pressurized distributor
- There is an overflow valve to prevent the pump from overloading and the pipeline pressure being too high.
- Oil viscosity 32-68cSt@40°C.

### Specification

Item Model	Motor Voltage (V)	Motor Power (W)	Lube Time (S)	Interval Time (M)	Working Pressure (MPa)	Max. Pressure (MPa)	Discharge (mL/min)	Outlet Diameter	Pressure Switch	Level Switch	Buzzer	Reservoir (L)	Weight (kg)
ADL-3	110VAC 220VAC	30	1-999	1-999	1.5	2.0	150	4mm 6mm	Optional	Yes	Yes	2(Resin)	2.7
												3(Resin)	3.6
												4(Resin)	4.2

## ADL3 Dimension

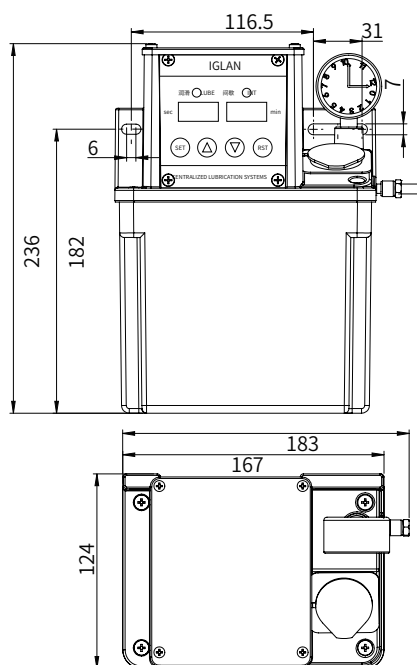

2L reservoir

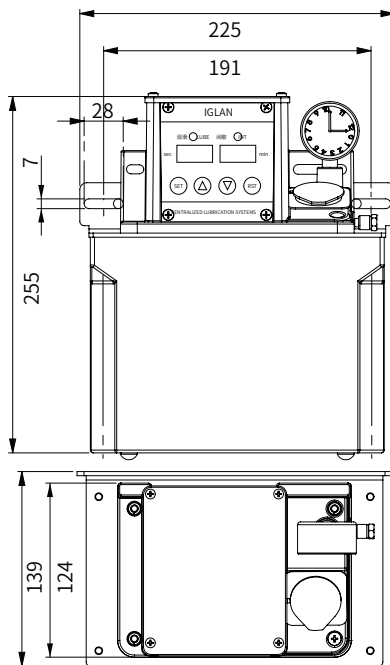

3L reservoir

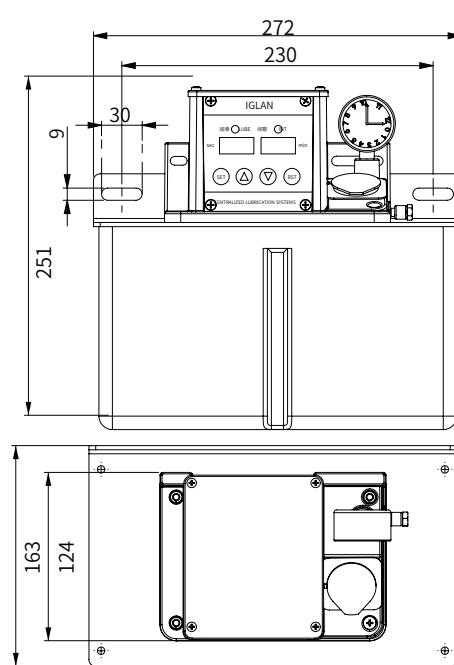

4L reservoir

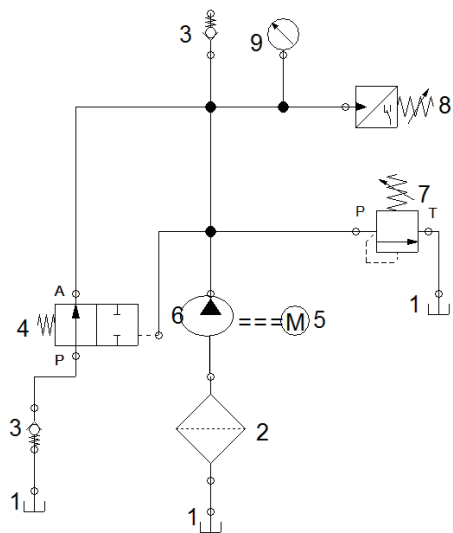

Oil circuit principle

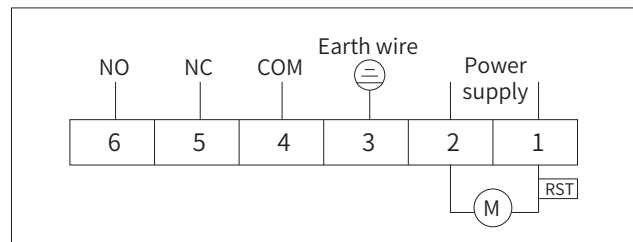

Wiring diagram

## Matching



LT distributor



DPB distributor



MO distributor

## ADL4 Pressure-relief Type



Ordercode **A D L - 4 - 2 - 0 - B - 1**

4	Pressure-relief type without controller
2	2L reservoir
3	3L reservoir
4	4L reservoir
0	No pressure switch
1	Pressure switch N.C.
2	Pressure switch N.O.
1	Level switch N.C.
2	Level switch N.O.
A	110 VAC
B	220 VAC

## Feature

1. The working time and interval time of the pump are controlled by the host PLC.
2. Equipped with liquid level switch, optional pressure switch, when the oil quantity or pressure is insufficient, the abnormal signal will be output.
3. The panel indicator light can display the lubrication and interval status.
4. The "FEED" key can be forced to lubricate.
5. Single lubrication time should be less than 2 minutes, interval time should be more than 5 times the lubrication time.
6. The motor is equipped with an overheat protector to prevent the motor from being overheated and overloaded.
7. There is a pressure relief device in the system, which needs to be used with LT/DPB/MO pressurized distributor.
8. Equipped with fuse to prevent short circuit and burn out IC board and motor.
9. Equipped with overflow valve, which can protect the pump and pipeline from damage caused by excessive pressure.
10. The oil viscosity range is 32-68cSt@40°C.

## Specification

Item Model	Motor Voltage (V)	Motor Power (W)	Lube Time (S)	Interval Time (M)	Working Pressure (MPa)	Max. Pressure (MPa)	Discharge (mL/min)	Outlet Diameter	Pressure Switch	Level Switch	Buzzer	Reservoir (L)	Weight (kg)
ADL-4	110VAC 220VAC	30	PLC	PLC	1.0	2.0	150	4mm 6mm	Optional	Yes	No	2(Resin)	2.7
												3(Resin)	3.6
												4(Resin)	4.2

## ADL4 Dimension

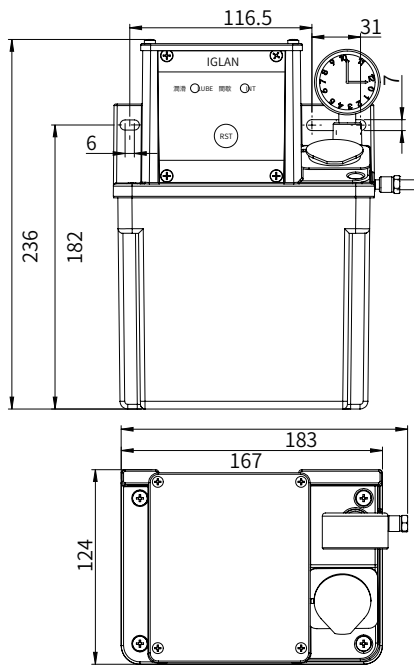

2L reservoir

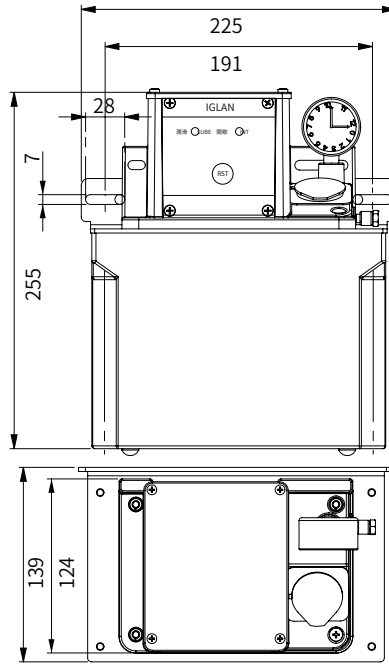

3L reservoir

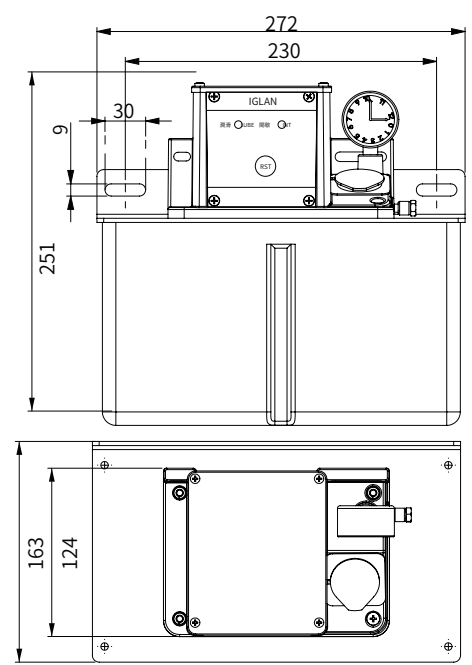

4L reservoir

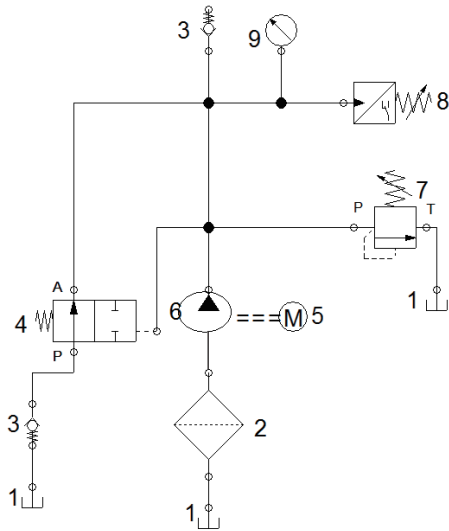

Oil circuit principle

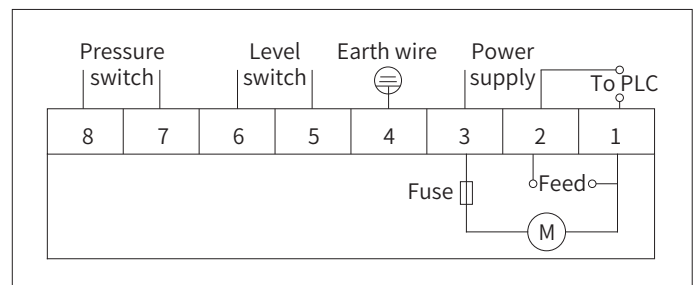

Wiring diagram

## Matching



LT distributor



DPB distributor



MO distributor

## AMT1 Resistance Type with Controller



Ordercode **A M T - 1 - 3 - 0 - A - S**

1	Resistance type with controller	S	LUBE(sec); INT(sec)
3	3L reservoir	M	LUBE(sec); INT(min)
4	4L reservoir	H	LUBE(sec); INT(hour)
6	6L reservoir	N	LUBE(sec); INT(time)
8	8L reservoir	A	110 VAC
20	20L reservoir	B	220 VAC
0	No pressure switch	C	12 VDC
1	Pressure switch N.C.	D	24 VDC

### Feature

- The system can set two action modes:
  - Lubrication: The lubrication time is executed when the machine is turned on.
  - Memory: When the power is turned on again, it will continue to execute the last unfinished interval time.
- The lubrication time and interval time can be adjusted and locked.
- Pressure switch (normally closed, optional). When the oil quantity or pressure is insufficient, the buzzer will give an alarm and output an abnormal signal.
  - Insufficient pressure displays Erp.
  - Insufficient liquid level displays Ero.
- LUB lubrication time: 1-999 seconds, INT interval time: 1-999 minutes (second/hour/time), can be customized.
- The panel indicator light can display the lubrication and interval status of the pump.
- Use the "RST" key to force lubrication or eliminate abnormal alarm signals.
- The special alloy gear pump is matched with the induction motor, which has long service life and low noise.
- There is no pressure relief device in the resistance system, and it is used with the proportional joint distributor.
- There is an overflow valve to prevent the pump from overloading and the pipeline pressure from being too high.
- The oil viscosity range is 32-68cSt@40°C.

### Specification

Item Model	Motor Voltage (V)	Motor Power (W)	Lube Time (S)	Interval Time (M)	Working Pressure (MPa)	Max. Pressure (MPa)	Discharge (mL/min)	Outlet Diameter	Pressure Switch	Level Switch	Buzzer	Reservoir (L)	Weight (kg)
AMT1	110VAC 220VAC 12VDC 24VDC	25/40	1-999	1-999	2.0	3.5	200 300	6mm	Optional	Yes	Yes	3(Resin)	4.2
												4(Metal)	6.5
												6(Metal)	7.0
												8(Metal)	7.9

## AMT1 Dimension

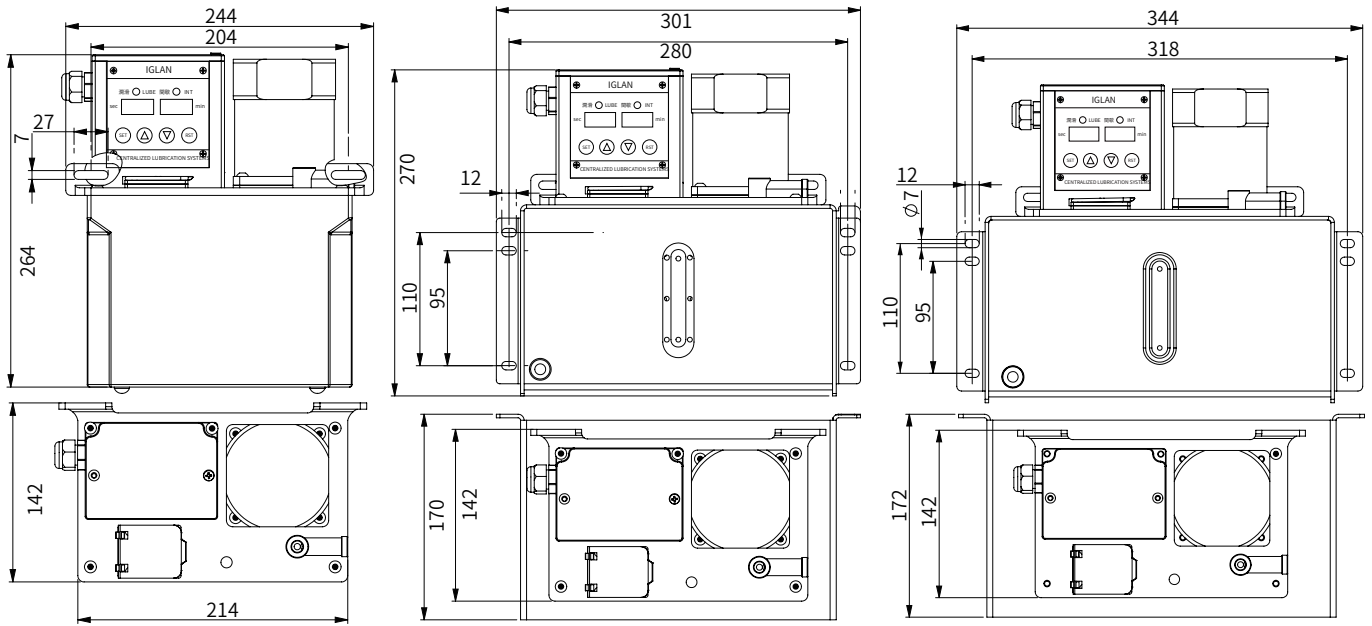

3L reservoir

4L reservoir

6L reservoir

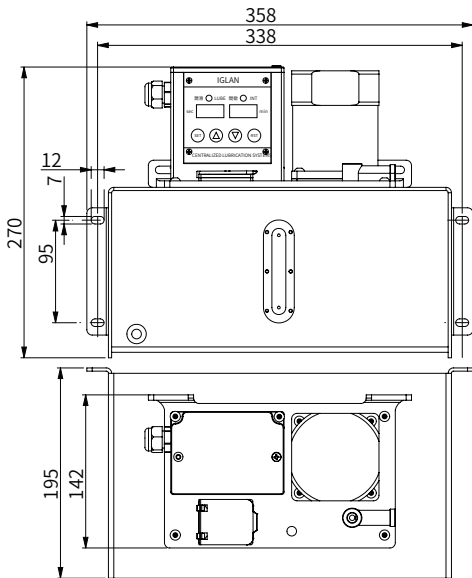

8L reservoir

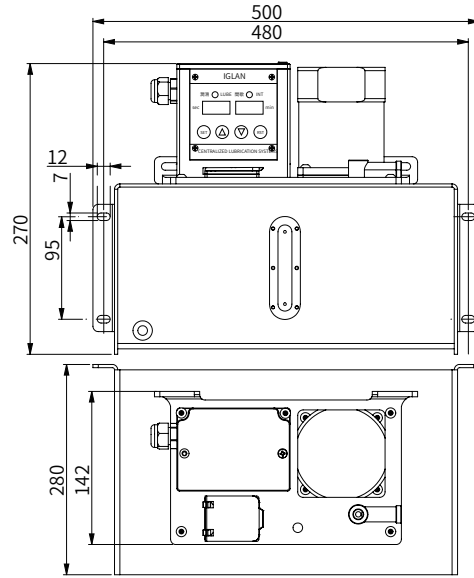

20L reservoir

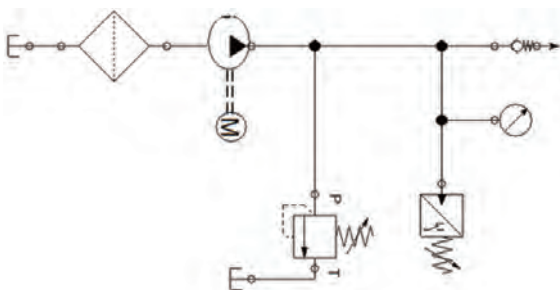

Oil circuit principle

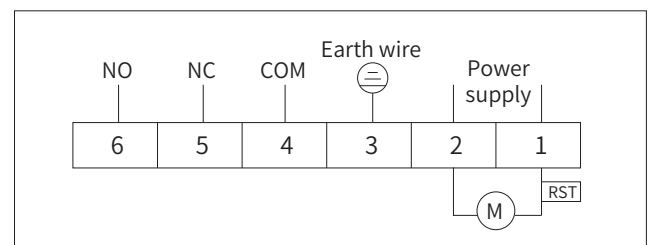

Wiring diagram



## AMT2 Resistance Type

Ordercode **A M T - 2 - 3 - 0 - A - 1**



2	Resistance type without controller	1	Level switch N.C.
3	3L reservoir	2	Level switch N.O.
4	4L reservoir	A	110 VAC
6	6L reservoir	B	220 VAC
8	8L reservoir	C	12 VDC
20	20L reservoir	D	24 VDC
0	No pressure switch	E	3-phase 220 VAC
1	Pressure switch N.C.	F	3-phase 380 VAC
2	Pressure switch N.O.	G	3-phase 440 VAC
		H	3-phase 460 VAC

## Feature

1. The working time and interval time of the pump are controlled by the host PLC.
2. Equipped with low oil level switch and pressure switch (optional), when the oil quantity or pressure is insufficient, it will output abnormal signal.
3. The panel indicator light can display the lubrication and interval status.
4. There is a "FEED" key in the system to force lubrication.
5. Proportional joints or B-type distributors are required in resistance systems.
6. Equipped with an overflow valve to avoid damage to the pump and pipeline due to excessive pressure.
7. Oil viscosity 32-68cSt@40°C.

## Specification

Item Model	Motor Voltage (V)	Motor Power (W)	Lube Time (S)	Interval Time (M)	Working Pressure (MPa)	Max. Pressure (MPa)	Discharge (mL/min)	Outlet Diameter	Pressure Switch	Level Switch	Buzzer	Reservoir (L)	Weight (kg)	
AMT2	110/220VAC 12/24VDC	25/40	PLC	PLC	2.0	3.5	200 300	6mm	Optional	Yes	Yes	3(Resin)	4.2	
		25										4(Metal)	6.5	
	3-phase 220 380/440/460												6(Metal)	7.0
													8(Metal)	7.9

## AMT2 Dimension

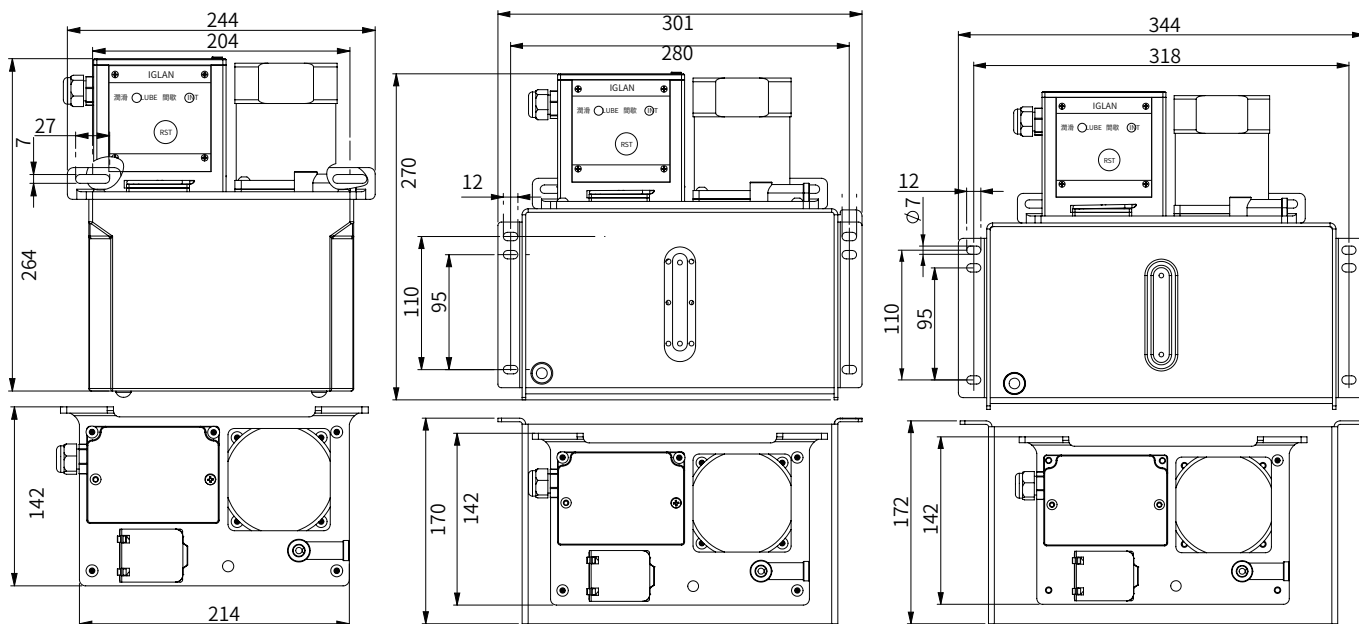

3L reservoir

4L reservoir

6L reservoir

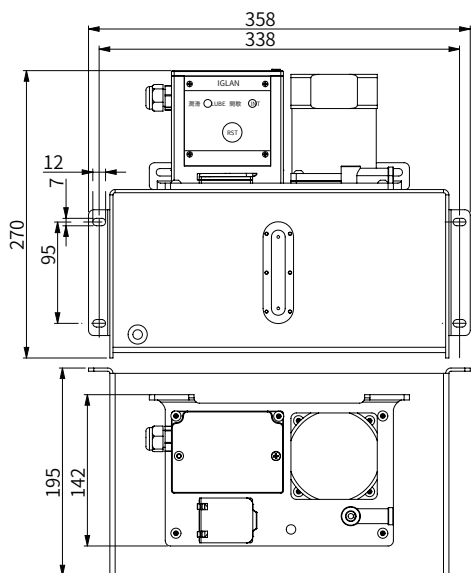

8L reservoir

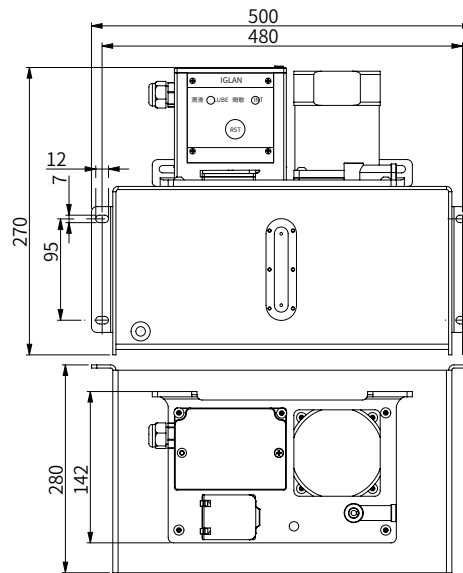

20L reservoir

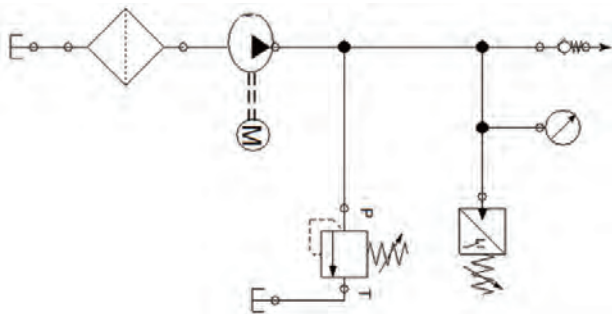

Oil circuit principle

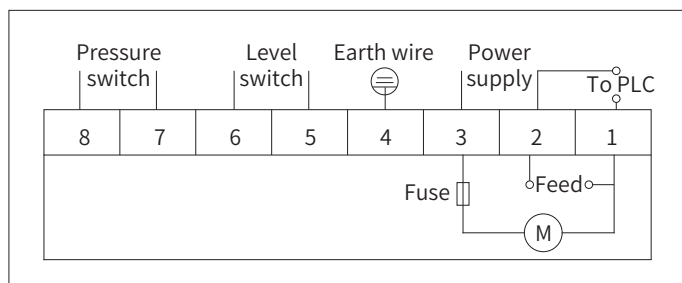

Wiring diagram

## AMT3 Pressure-relief Type with Controller



Ordercode **AMT-3-3-0-A-S**

3	Pressure-relief type with controller	S	LUBE(sec); INT(sec)
3	3L reservoir	M	LUBE(sec); INT(min)
4	4L reservoir	H	LUBE(sec); INT(hour)
6	6L reservoir	N	LUBE(sec); INT(time)
8	8L reservoir	A	110 VAC
20	20L reservoir	B	220 VAC
0	No pressure switch	C	12 VDC
1	Pressure switch N.O	D	24 VDC

### Feature

- The system can set two action modes:
  - Lubrication: The lubricating time is performed when the power is turned on.
  - Memory: Power off and then on again to continue the unfinished interval time.
- The lubrication time and interval time can be adjusted, and the set lubrication and interval time can be locked.
- The pressure switch is normally closed, optional. When the oil quantity or pressure is insufficient, the buzzer will give an alarm and output an abnormal signal.
  - Insufficient pressure display: Erp.
  - Insufficient liquid level display: Ero.
- LUB is lubrication time: 1-999 seconds, INT is intermittent time: 1-999 minutes (seconds/hours/times), which can be customized.
- The panel indicator light can display the lubrication and interval status.
- The system can use the "RST" key to force lubrication or eliminate abnormal alarm signals.
- There is a pressure relief device in the pressure relief system, so it needs to be matched with a LT/DPB/MG distributor.
- Equipped with an overflow valve to prevent the pump from overloading and the pipeline pressure from being too high.
- Special alloy gear pump and induction motor, long service life and low noise.
- Applicable oil viscosity range is 32-68cSt@40°C.

### Specification

Item Model	Motor Voltage (V)	Motor Power (W)	Lube Time (S)	Interval Time (M)	Working Pressure (MPa)	Max. Pressure (MPa)	Discharge (mL/min)	Outlet Diameter	Pressure Switch	Level Switch	Buzzer	Reservoir (L)	Weight (kg)
AMT3	AC110 AC220 DC12 DC24	25/40	1-999	1-999	2.0	3.5	200 300	6mm	Optional	Optional	Yes	3(Resin)	4.5
												4(Metal)	6.5
												6(Metal)	7.0
												8(Metal)	8.0

## AMT3 Dimension

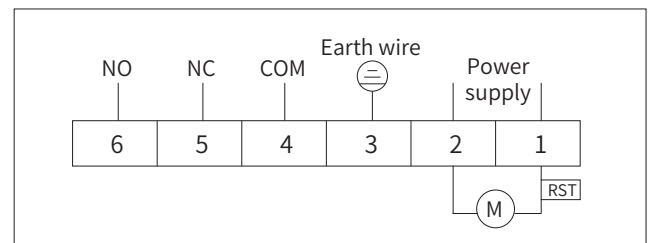
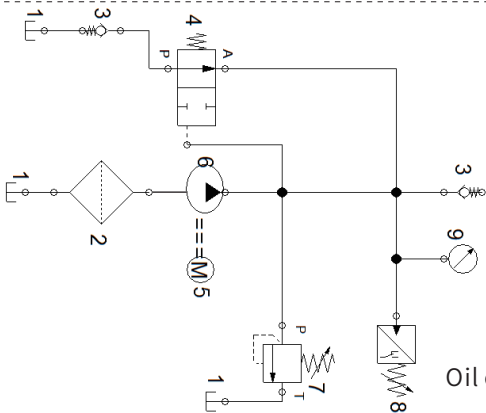
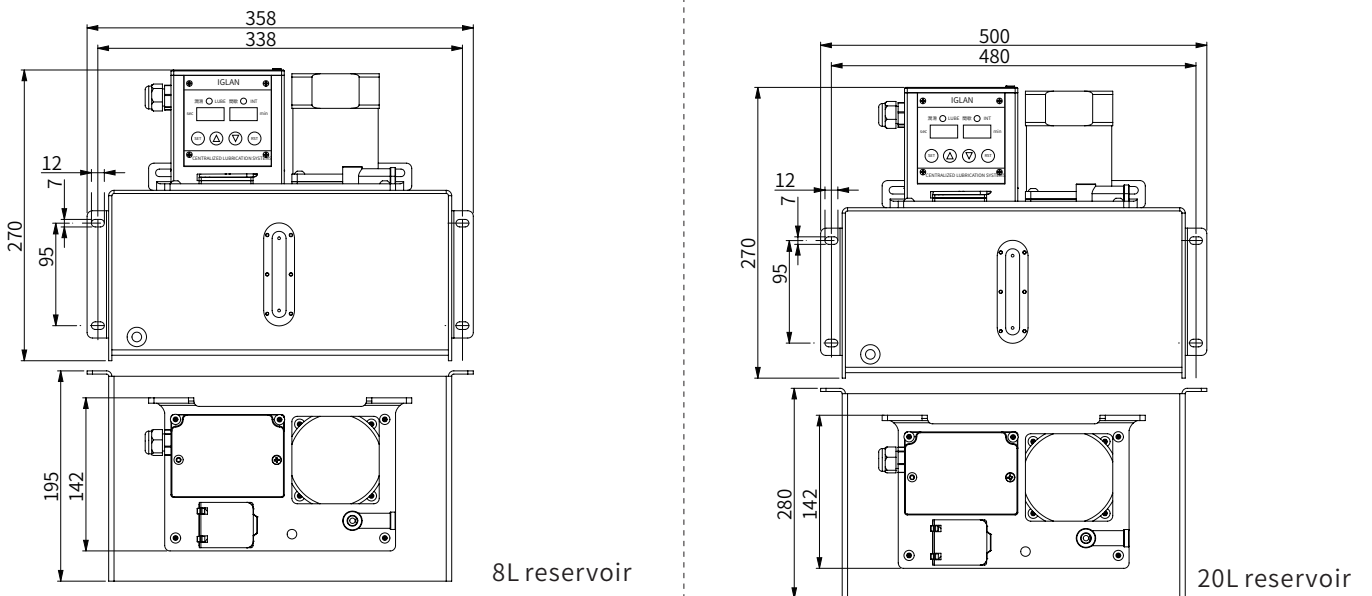
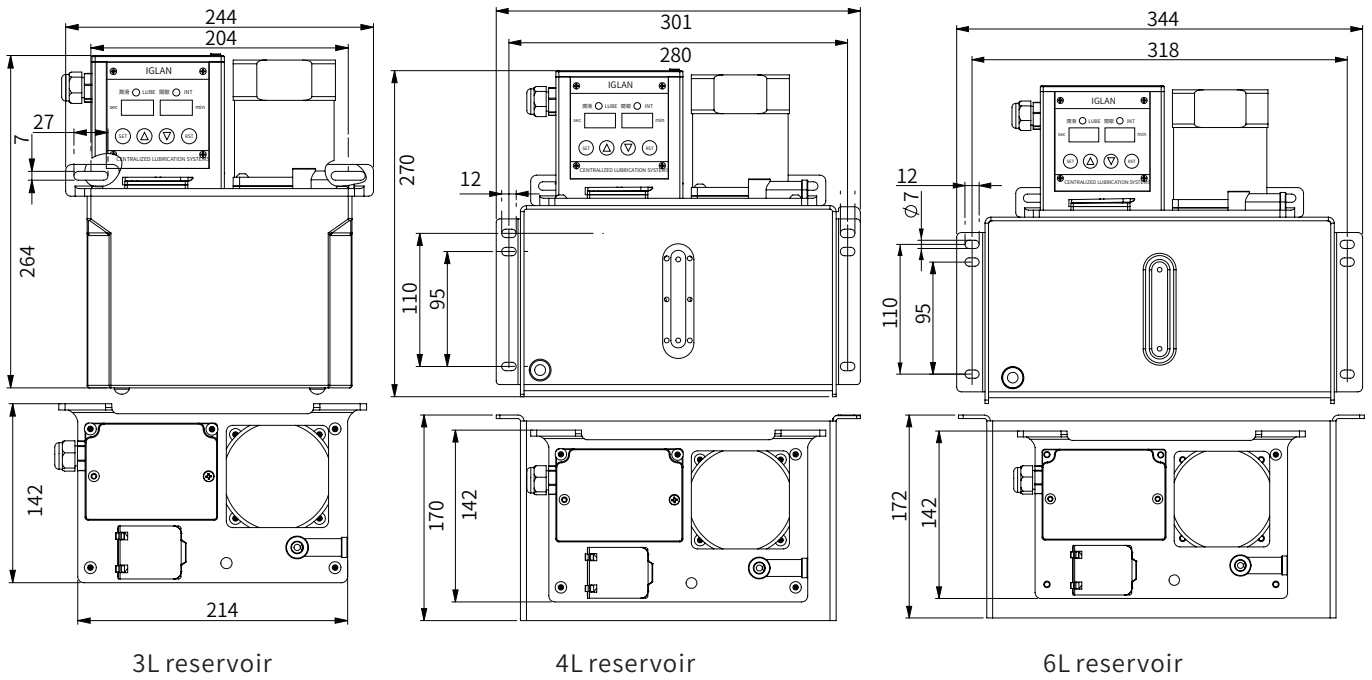

## AMT4 Pressure-relief Type



Ordercode **A M T - 4 - 3 - 0 - A - 1**

4	Pressure-relief type without controller	1	Level switch N.C.
3	3L reservoir	2	Level switch N.O.
4	4L reservoir	A	110 VAC
6	6L reservoir	B	220 VAC
8	8L reservoir	C	12 VDC
20	20L reservoir	D	24 VDC
0	No pressure switch	E	3-phase 220 VAC
1	Pressure switch N.C.	F	3-phase 380 VAC
2	Pressure switch N.O.	G	3-phase 440 VAC
		H	3-phase 460 VAC

## Feature

1. The working cycle of the pump is controlled by the host PLC: working time and interval time.
2. Equipped with liquid level switch and pressure switch (optional). When the oil quantity or pressure is insufficient, the abnormal signal will be output.
3. The panel indicator light can display the lubrication status of the lubrication pump.
4. There is a "FEED" key in the system, which can be forced to lubricate.
5. The special alloy gear pump is matched with the induction motor, which has long service life and low noise.
6. There is a pressure relief device in the volume system, which needs to be used with LT/DPB/MO distributor.
7. Equipped with overflow valve, which can protect the pump and pipeline from damage due to excessive pressure.
8. Oil viscosity range is 32-68cSt@40°C.

## Specification

Item Model	Motor Voltage (V)	Motor Power (W)	Lube Time (S)	Interval Time (M)	Working Pressure (MPa)	Max. Pressure (MPa)	Discharge (mL/min)	Outlet Diameter	Pressure Switch	Level Switch	Buzzer	Reservoir (L)	Weight (kg)
AMT4	110/220VAC 12/24VDC	25	PLC	PLC	2.0	3.5	200 300	6mm	Optional	Yes	Yes	3(Resin)	4.2
												4(Metal)	6.5
	3-phase 220 380/440/460	25/40										6(Metal)	7.0
												8(Metal)	7.9





## AMH1 Oil Circulation Pump with Controller



Ordercode **AMH-1-8-1-A-1**

1	Oil Circulation type with Controller	1	Level switch N.C.
8	8L reservoir	2	Level switch N.O.
0	No pressure switch	A	110 VAC
1	Pressure switch N.C.	B	220 VAC
		C	12 VDC
		D	24 VDC

### Feature

1. The oil circulation lubrication pump can save oil, and there is a filter screen in the circulation port to filter impurities.
2. The pump has its own controller, LUB lubrication time: 1-999 seconds (minutes), INT interval time: 1-999 minutes (seconds/hours/times), special requirements can be customized.
3. Equipped with a liquid level switch and a pressure switch (normally closed, optional), when the oil volume or pressure is insufficient, the buzzer will give an alarm and output an abnormal signal.
4. The panel indicator light can show the lubrication and intermittent status of the pump.
5. The system can use the "RST" key to force lubrication or eliminate abnormal alarm signals.
6. The pump is equipped with special alloy gear pump and induction motor, which has long service life and low noise.
7. After the installation and piping of the machine are completed, the pipes need to be filled with oil before starting to use.
8. Equipped with a pressure regulating valve device, the pressure can be adjusted according to customer needs, and can be viewed from the pressure gauge.
9. Use oil viscosity 32-68cSt@40°C.

### Specification

Item Model	Motor voltage (V)	Motor voltage (W)	LUBE time (S)	Interval time (M)	Working pressure (MPa)	Max pressure (MPa)	Discharge (mL/min)	Outlet diameter	Pressure switch	Level switch	Buzzer	Reservoir capacity (L)	N.W (kg)
AMH1	AC110 AC220 DC12 DC24	25 40	1-999	1-999	1.5	2.0	250 500	6mm	Optional	Yes	Yes	8(metal)	8.9

## AMH2 Oil Circulation Pump



Ordercode **AMH-2-8-1-A-1**

1	Oil Circulation type without Controller	1	Level switch N.C.
8	8L reservoir	2	Level switch N.O.
0	No pressure switch	A	110 VAC
1	Pressure switch N.C.	B	220 VAC
2	Pressure switch N.O.	C	12 VDC
		D	24 VDC
		E	3-phase 220 VAC
		F	3-phase 380 VAC
		G	3-phase 440 VAC
		H	3-phase 460 VAC

## Feature

1. The working time and interval time of the pump are controlled by the host PLC. It can also be operated continuously for a long time without PLC control.
2. The oil circulation lubrication pump saves the amount of lubricating oil, and the oil circulation port is equipped with a filter device to filter impurities.
3. Equipped with liquid level switch and pressure switch (optional), when the oil quantity or pressure is insufficient, the abnormal signal will be output.
4. After the pump installation and piping are completed, the oil pipe needs to be filled with oil before starting to use.
5. There is a "FEED" key in the system, which can be forced to lubricate.
6. The special alloy gear pump is matched with the induction motor, which has long service life and low noise.
7. There is a pressure regulating valve device, which can adjust the pressure according to customer requirements and check it from the pressure gauge.
8. The viscosity of the oil used is 32-68cSt@40°C.

## Specification

Item Model	Motor voltage (V)	Motor voltage (W)	LUBE time (S)	Interval time (M)	Working pressure (MPa)	Max pressure (MPa)	Discharge (mL/min)	Outlet diameter	Pressure switch	Level switch	Buzzer	Reservoir capacity (L)	N.W (kg)
AMH2	110/220VAC 12/24VDC	25/40	PLC	PLC	1.5	2.0	250 500	6mm	Optional	Optional	No	8(metal)	8.9
	3-phase 220 380/440/460	25											

## AMH1 & AMH2 Dimension

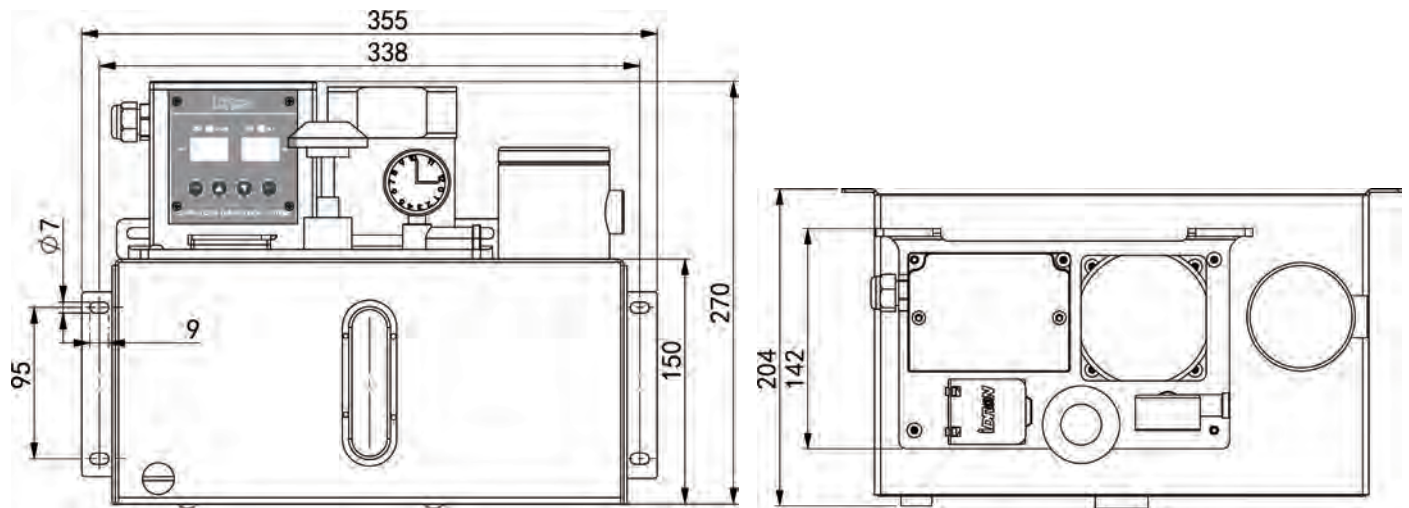

## Oil Circulation Lubrication System Layout

Type-B Adjustable Distributor

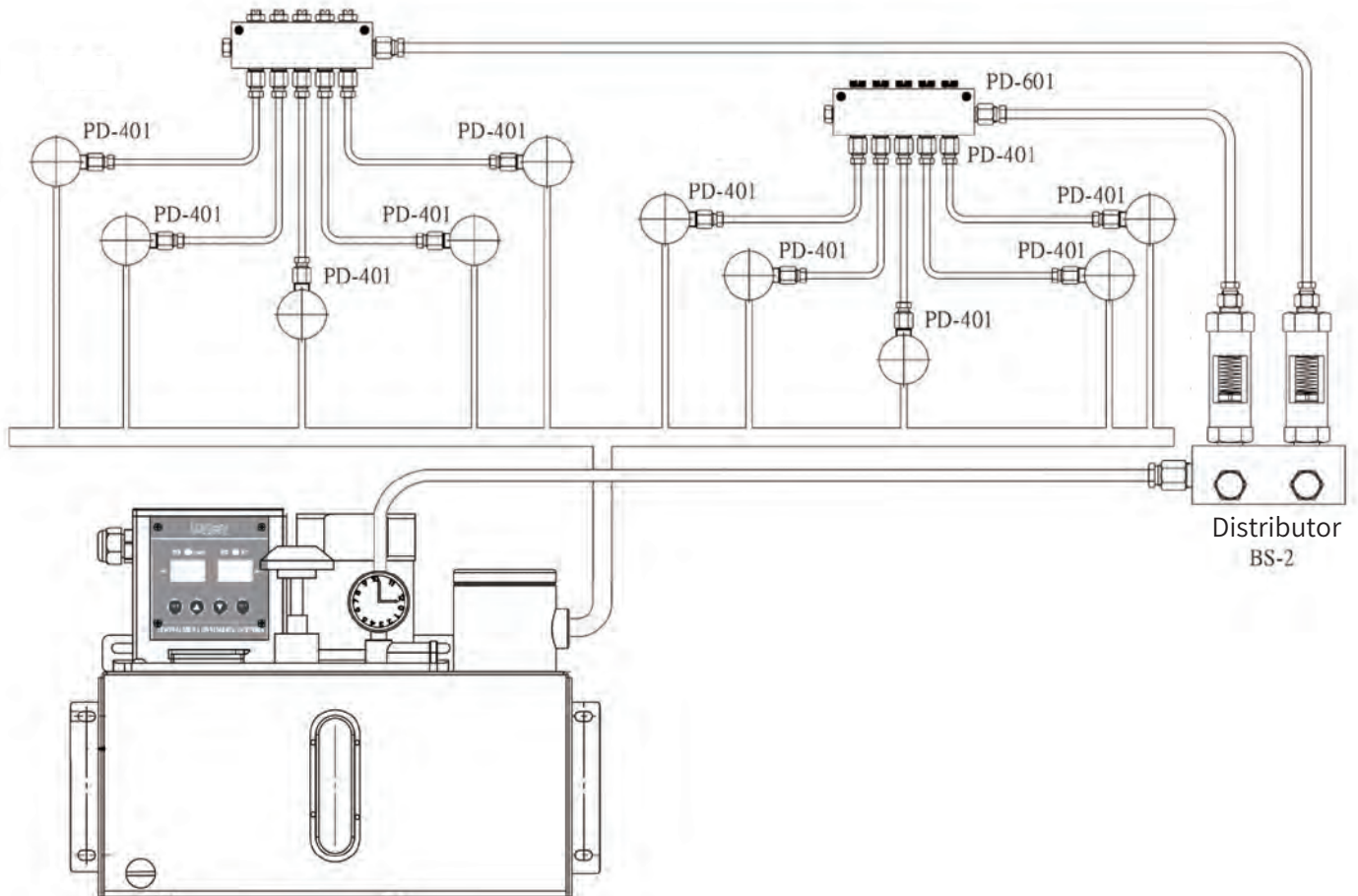

## MD Drip Lubricator



### Order code

MD - 2 - 2 - N - 4 - 6

1	No solenoid valve	4	Outlet dia. Φ4
2	with solenoid valve	6	Outlet dia. Φ6
03	0.3L reservoir	8	Outlet dia. Φ8
10	0.8L reservoir	1	1 outlet
20	2.0L reservoir	2	2 outlets
F	No pressure switch	3	3 outlets
N	Pressure switch N.C.	4	4 outlets

### Feature

Automatic oil refilling.

Regular quantitative lubrication to prolong the service life of the equipment.

Large-capacity reservoir, reducing number of refilling.

Reduce oil by more than 40%.

High precision oil volume control valve.

Built-in filter to prevent oil from being polluted.

Oil cup anti-aging, impact resistance, high temperature resistance.

Optional accessories:

1. Controller: timing control, counting control.
2. Solenoid valve: 220VAC, 24VDC.
3. Oil volume control valve: single-way, multi-way.
4. Oil drip tube: 4mm hose or copper tube.
5. Low oil level switch.

Application: lubrication of punches, chains, wire ropes, open gears, etc.

### Dimension

### Specification

Model	Reservoir(L)	Mounting hole	Length(mm)	Width(mm)	Height(mm)	N.W(kg)	Reservoir
MD	0.3	144	168	117.5	1226	1.88	Resin
	0.8	170	204	161.5	221	2.50	
	2.0	250	277	160.5	240	3.40	

## Electromagnetic Pumping

### Feature

1. Large flow and small volume.
2. Low power loss.
3. The principle is simple and the failure rate is low.
4. Flow varies with length of the tube and oil viscosity.
5. For machines require long-term lubrication or cooling.
6. Suitable for small mechanical equipment, such as lathes, milling machines, grinders, punches, etc.
7. When the temperature rises, the pressure drops.
8. The tube length can be customized, the standard is 300mm PU tube.

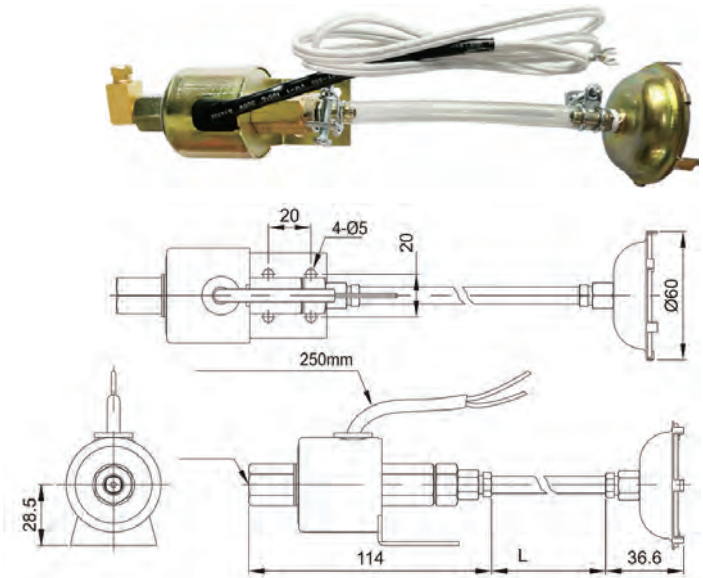

Model	Voltage	N.W	Motor	Discharge	Pressure	Outlet	Temperature	Viscosity
YEM-2501	110VAC	400g	25W	300mL/min	0.8~1.2bar	PT1/8	Max 85°C	36-68cSt@40°C
YEM-2502	220VAC	450g						

## GA-25 Gear Pump

### Feature

1. Small size, high cost performance and high practicability.
2. The gear pump body is made of special alloy steel, which is strong and durable in torque.
3. The output pressure and temperature, no noise, can ensure that each lubricating point has oil flow out, which can meet the needs of general large-scale machinery.
4. The length of L can be customized, standard length is 65mm.

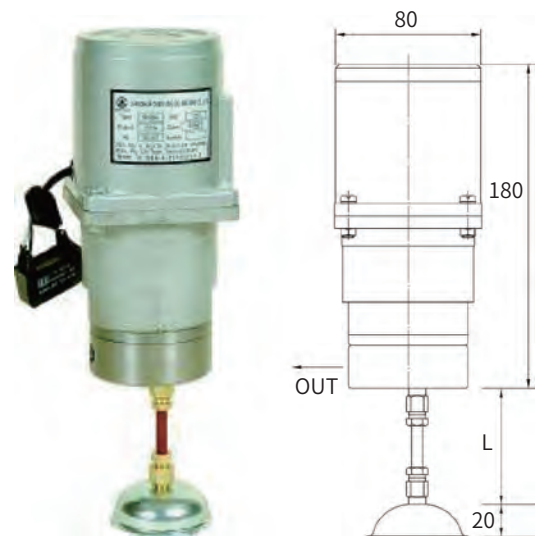

Model	Motor	Voltage	Current	Frequency	Discharge	Pressure	Outlet	Viscosity
GA-25	25W	110, 220V 380V, 24V	0.7A/0.2A 0.3A/1.2A	50Hz, 60Hz	250mL/min	Max 1.2MPa	Φ4/Φ6	2-68cSt@40°C

### Order code

GA ————— 25 ————— B

**Discharge**

25 = 250mL/min; 50 = 500mL/min

**Voltage**

A = 110V; B = 220V; D = 24VDC; E = 3-phase 220V; F = 3-phase 380V



## Pump Motor (One-way rotation)

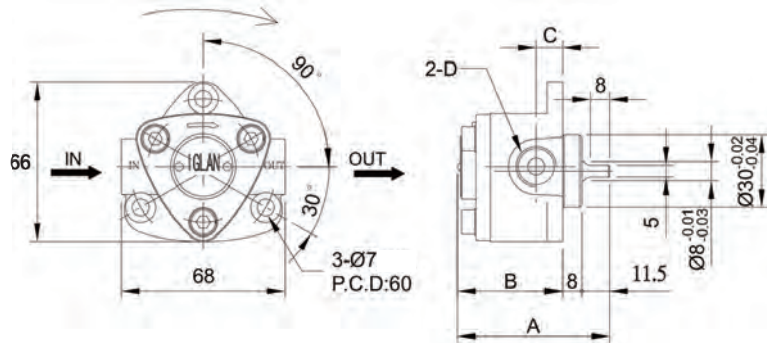

1. One-way rotary oil pump is called a triangle pump, which rotates in one direction and is used with a 1/4HP direct motor.
2. According to the flow rate, it is divided into TOP-10A and 13A, and the standard oil pump rotates clockwise.
3. A pressure regulating valve can be installed, and the pressure adjustment range is 0-5bar.
4. Fuel tank, oil return device, fan, etc. can be installed.
5. The speed range is 1420~1720rpm, and there is a low speed 450~1200rpm type TOP-12L.
6. The viscosity of the oil used is R32-68cSt @40°C.
7. The applicable temperature range is 0°C~90°C.

Model	1420rpm	1720rpm	Common range	A(mm)	B(mm)	C(mm)	D(mm)	Weight	Pressure
TOP-10A	1.1L/min	1.4L/min	1420-1720	56.5	37	37	PT1/8	570g	5bar
TOP-11A-1	2.2L/min	2.7L/min	1420-1720	56.5	37	37	PT1/8	575g	
TOP-11A-2	2.2L/min	2.7L/min	1420-1720	56.5	37	37	PT1/4	575g	
TOP-12A	3.7L/min	4.5L/min	1420-1720	62.5	43	43	PT1/4	650g	
TOP-12L	3.4L/min	4.2L/min	1420-1720	62.5	43	43	PT1/4	650g	
TOP-3A	6.5L/min	7.9L/min	1420-1720	77.5	58	58	PT3/8	850g	

## Pump Motor (Reversible)

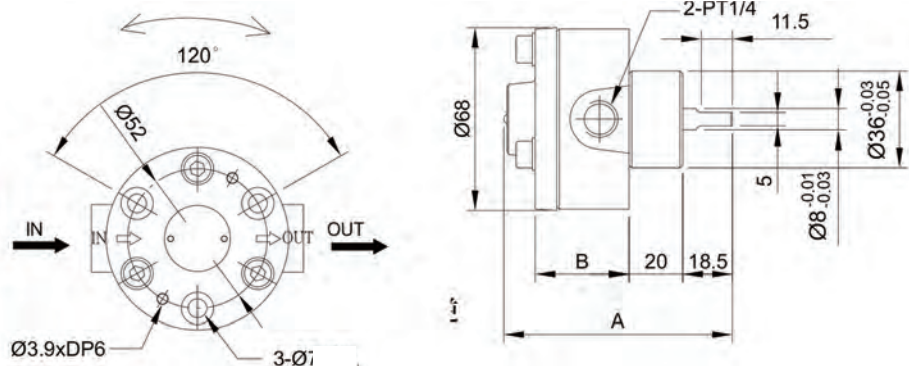

1. Reversible oil pump, fixed by 3 M6x16L screws, the direction of the oil inlet and the oil outlet is fixed, the axis rotates clockwise and can also be rotated counterclockwise.
2. It cannot be used with a direct-drive motor. It is only suitable for mounting on the gearbox.
3. According to the different flow, it is divided into DRA-1FS~3FS, and the maximum rotation speed is 2000rpm.
4. The applicable oil viscosity is R32~68cSt @40°C.



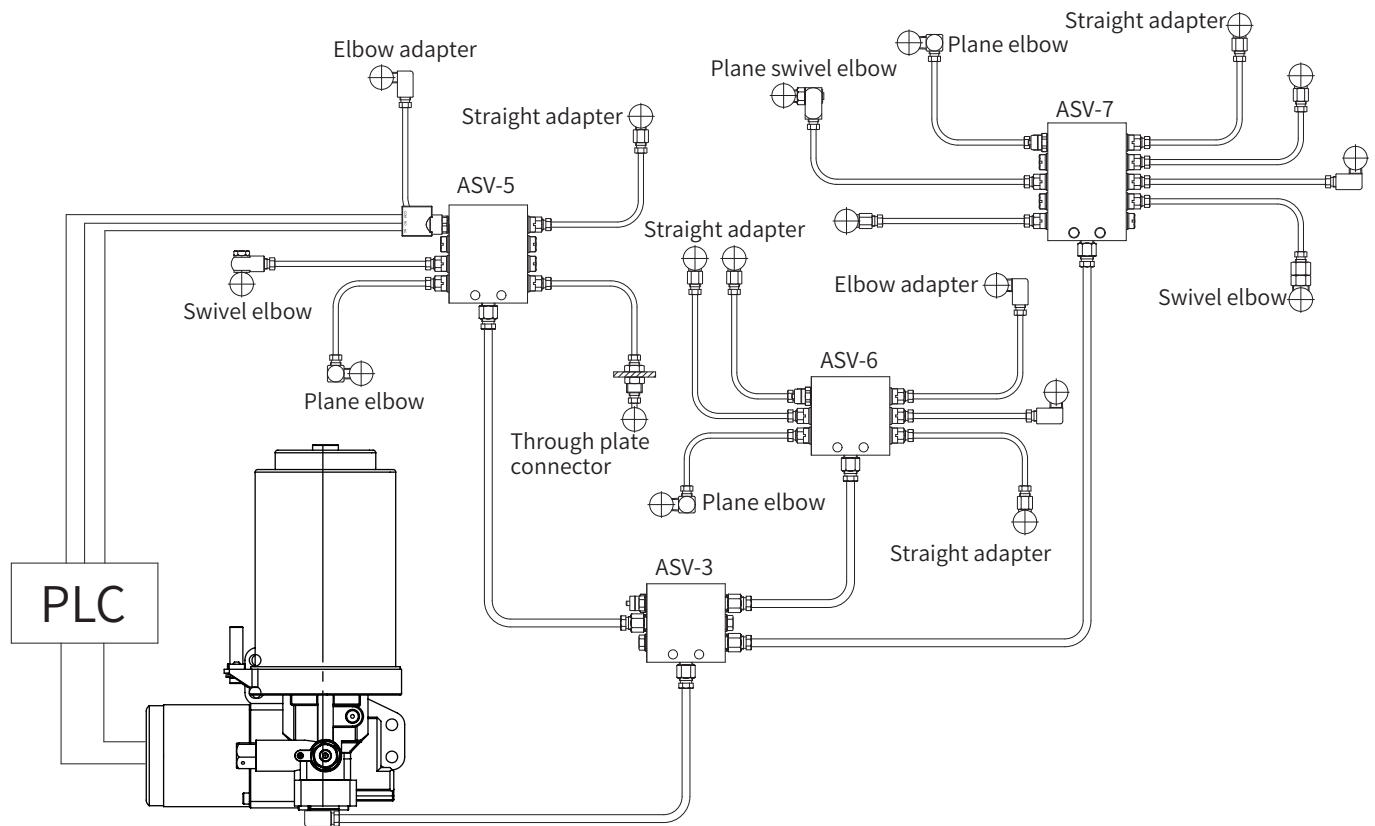

## Principle

When the progressive lubrication system is running, the outlets of the progressive distributor are discharged in a certain order. The grease grade is NLGI 000~2#, metering volume range 0.05-20mL/cyc, the working pressure is 1~30MPa, filtration precision is 150 $\mu$ , and the number of lubrication points is 1~200. The progressive distributor can be connected up to three stages.

The system can be equipped with a cycle indicating rod and a clogging alarm to monitor the lubricant supply condition. Once the system is blocked or no lubricant is produced, the alarm will send an alarm signal. The movement of the indicating rod can also be timed or counted by the controller. The progressive distributor can be divided into two types, one-piece

## Feature

1. The metering volume of the progressive system is accurate, and it can be operated and monitored in an independent area, and it is easy to determine the fault point.
2. The system is used in mining machines, steel, metallurgy machines, water conservancy machines, cement machines, transport vehicles, port machines, construction machines, forging machines, etc.

## Product

Lubrication pump: AGP, DRB, AHG1, AHG2, AHGS1, AHGS2, EGM.

Distributor: ASV, AVK, AVP, AUV.

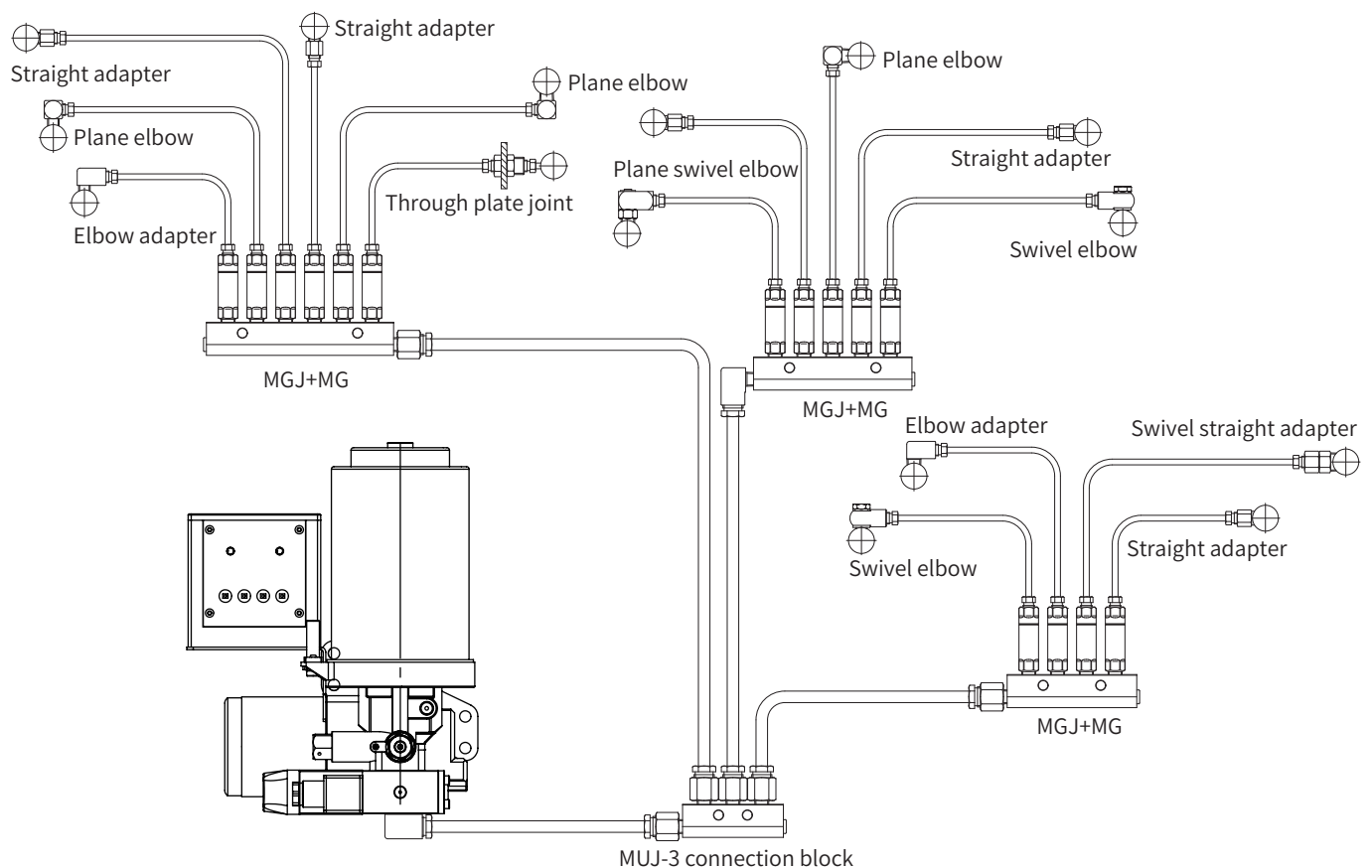

## Principle

The pressure relief grease lubrication system is a periodic lubrication system that can precisely lubricate the lubrication points as needed, with an error rate of about 5%. The grease supply is controlled by the distributor, the minimum grease supply is 0.03mL/cyc, and the maximum is 0.5mL/cyc. The working pressure of the system is 4.0~25MPa, viscosity range is NLGI 000~2#, the filtration precision is 15 $\mu$ , and 1~200 points can be lubricated.

System principle: The pump outputs pressure lubricant, system pressure rises, the original lubricant in the chamber of the distributor is discharged, pressure switch works, the pump stops, the pressure relief valve works, and a cycle is completed.

## Feature

1. It is more convenient to increase or decrease the lubrication point. The oil supply is accurate. And the system pressure can be detected.
2. This system is used in: light industry machinery, textile machinery, machine tools, packaging machinery, printing machinery, woodworking machinery, plastic machinery, forging machinery, etc.

## Product

Lubrication pump: AMG3, AMG4, AHG3, AHG4, AHGS3, AHGS4, EGM.

Distributor: DPB, MU, MG, MG2.

## EGM Progressive Type



### Order code

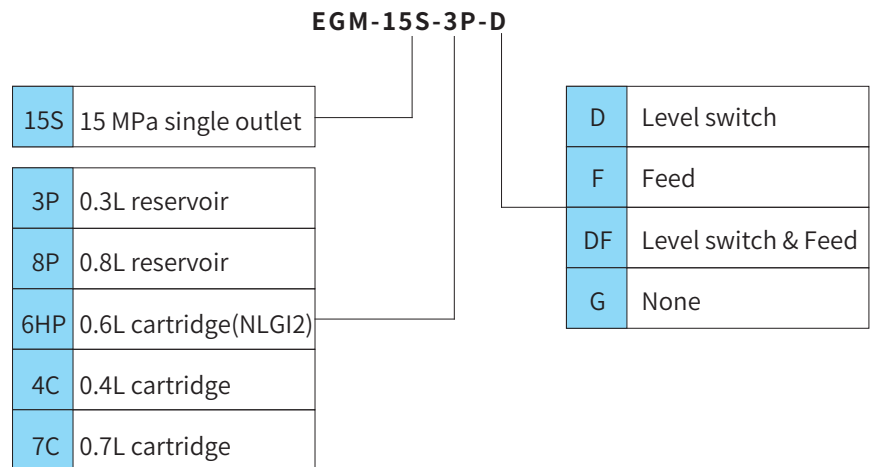

## Feature

1. After the lubricant in the cartridge is used up, it cannot be refilled. Please use the recommended lubricant.
2. Do not use lubricants containing molybdenum disulfide.
3. Use lithium-based grease, if non-lithium grease must be used, please contact us.
4. Do not use any lubricant that may corrode brass or rubber.
5. When refilling the lubricant, be sure to inject it from the filler nozzle to avoid the sundries being mixed into the lubricant.
6. Avoid continuous and uninterrupted work.
7. The ratio of interval time to lubrication time is 3:2, and the single lubrication time does not exceed 10 minutes. Failure to observe this may result in damage to the solenoid valve, preventing the pump from building pressure.
8. Lurbitants: NLGI 0#, 00#, 000#, LUBE 2#.

## Specification

Rated voltage	Starting current	Rated current	Max. current	Discharge	Working pressure	Protection class
24 VDC±10%	3.0 A	2.5 A (25° C)	4.5 A	15mL/min	10MPa	IP54
Manual switch	Manual switch	Manual switch	Level switch	Level switch	Level switch	Certification
24VDC	3.0 A	A-contact	24VDC	0.5 A	A-contact	CE

## EGM Progressive Type

### Dimensions

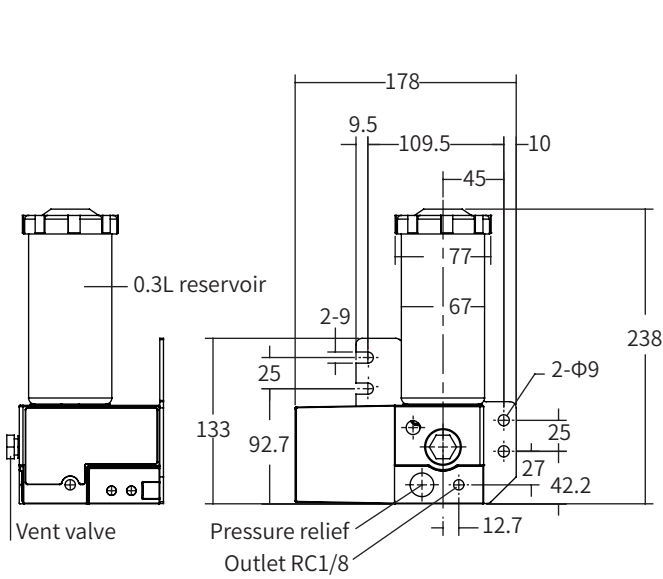

EGM- 0.3L reservoir

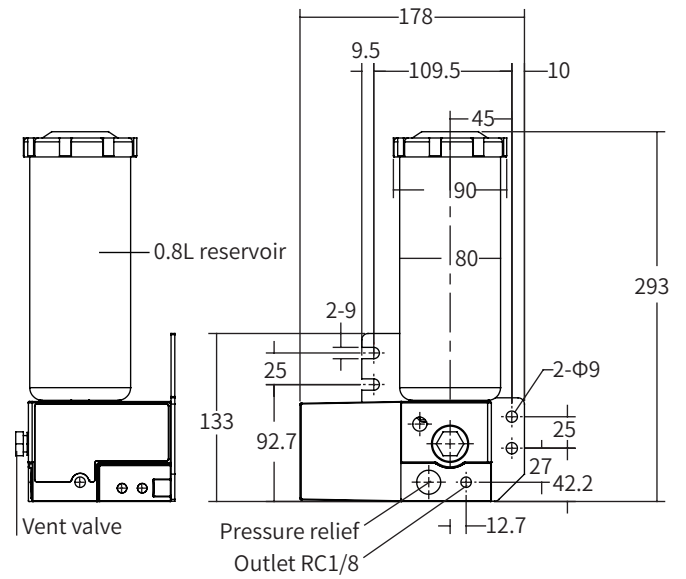

EGM- 0.8L reservoir

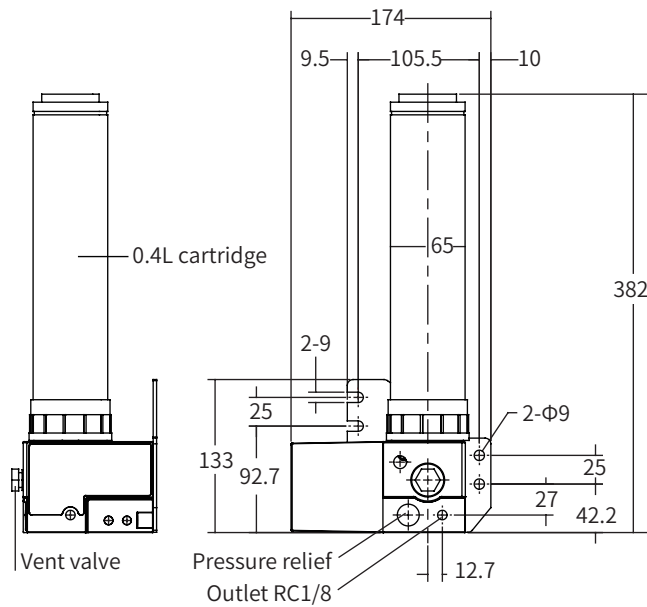

EGM- 0.4L cartridge

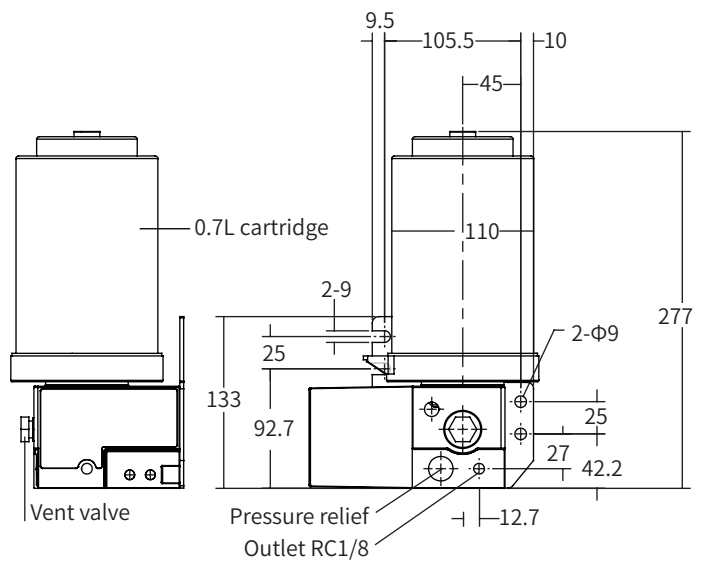

EGM- 0.7L cartridge

## EGM Pressure-relief Type

### Order code



### EMG-5-T-4C-D

5	5 MPa
8	8 MPa
10	10 MPa
T	Double outlet
S	Single outlet

D	Level switch
F	Feed
DF	Level switch & Feed
G	None
4C	400mL cartridge
7C	700mL cartridge
3P	300mL reservoir
8P	800mL reservoir

## Feature

1. After the lubricant in the cartridge is used up, it cannot be refilled. Please use the recommended lubricant.
2. Do not use lubricants containing molybdenum disulfide.
3. Use lithium-based grease, if non-lithium grease must be used, please contact us.
4. Do not use any lubricant that may corrode brass or rubber.
5. When refilling the lubricant, be sure to inject it from the filler nozzle to avoid the sundries being mixed into the lubricant.
6. Avoid continuous and uninterrupted work.
7. The ratio of interval time to lubrication time is 3:2, and the single lubrication time does not exceed 10 minutes. Failure to observe this may result in damage to the solenoid valve, preventing the pump from building pressure.
8. Lubricants: NLGI 0#, 00#, 000#, LUBE 2#.

## Specification

Rated voltage	Starting current	Rated current	Max. current	Discharge	Working pressure	Protection class
24 VDC±10%	3.0 A	2.5 A (25° C)	4.5 A	15mL/min	5MPa	IP54
Manual switch	Manual switch	Manual switch	Level switch	Level switch	Level switch	Certification
24VDC	3.0 A	A-contact	24VDC	0.5 A	A-contact	CE

## EGM Pressure-relief Type

### Dimensions

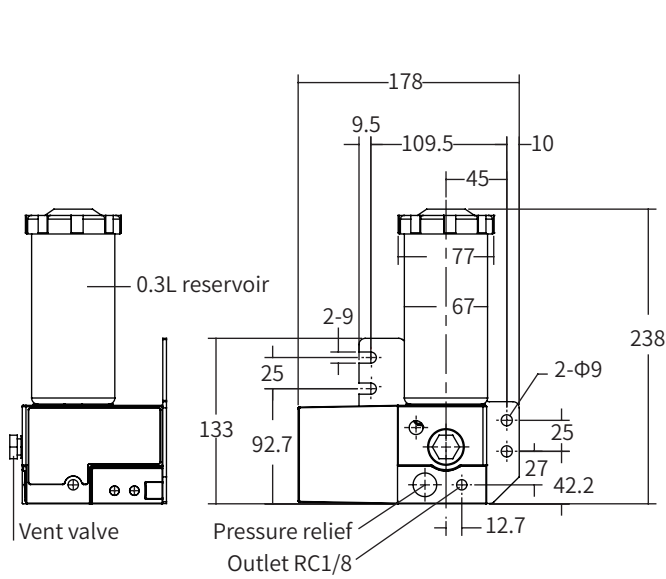

EGM- 0.3L reservoir

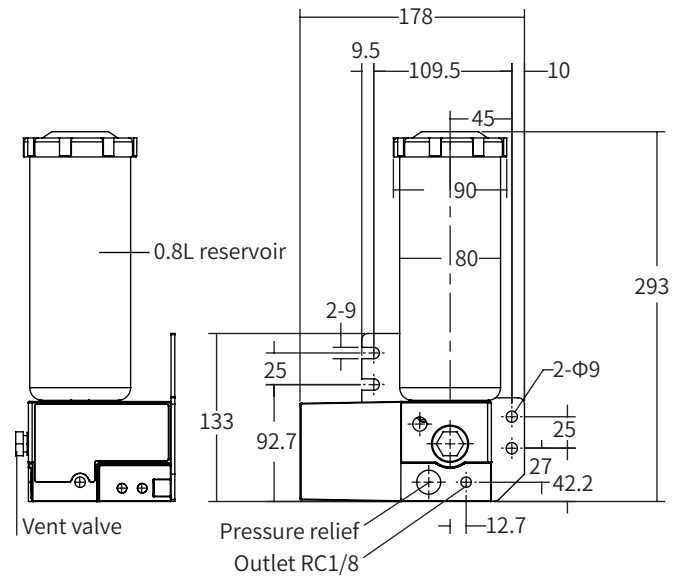

EGM- 0.8L reservoir

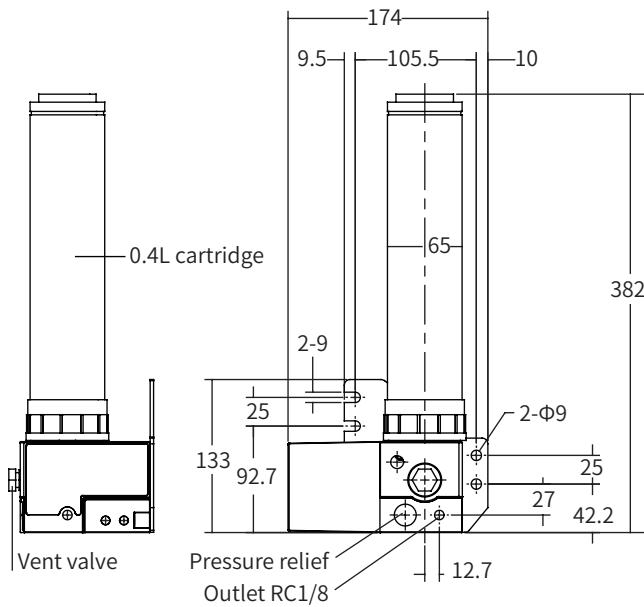

EGM- 0.4L cartridge

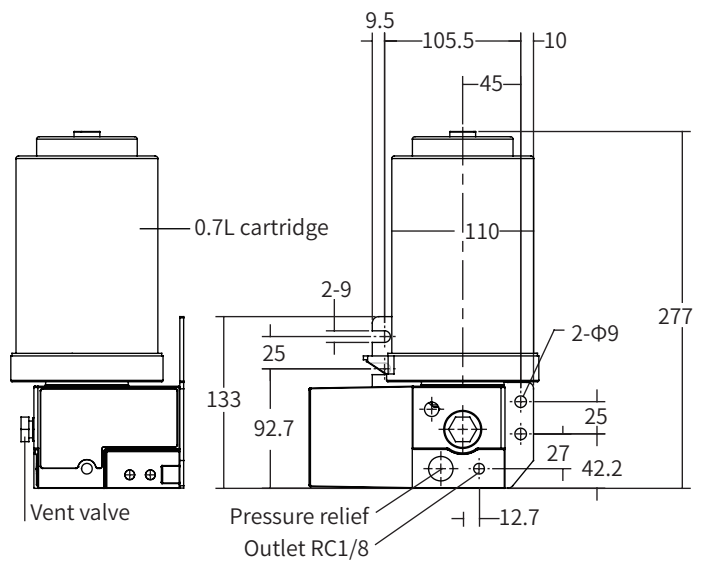

EGM- 0.7L cartridge



## AHGS1 Progressive with Controller



Order code **AHGS-1-7-D-6-1**

1	Progressive type with controller	1	Level switch N.O.
7	0.7L cartridge	0	No Level switch
A	110VAC	6	Outlet dia. Φ6
B	220VAC	8	Outlet dia. Φ8
C	12VDC		
D	24VDC		

### Dimension

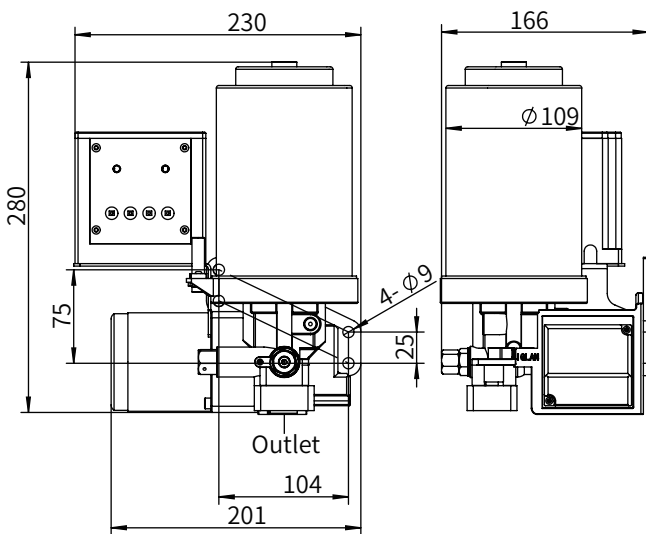

### Feature

1. The pump has its own controller to control the lubrication and interval time. It is easy to operate. It has a buzzer, and a warning sound will be issued when there is an abnormality.
2. There is a pressure regulating valve to control the working pressure of the pump and protect its work safety.
3. A vent valve is provided to discharge the air in the pump cavity to ensure smooth discharge of the pump.
4. With pressure plate, vacuum driven lubricant suction.
5. Low-level transmitter can be installed.
6. After the lubricant in the cartridge is used up, it cannot be refilled. Ensure lubricant quality and avoid debris.
7. Matching distributor: ASV, ASVB, AVK, AVP series.
8. Lubricants: 000#, 00#, 0#, 1# lithium-based grease.

### Specification

Model	Lube time	Interval time	Discharge	Voltage	Power	Cartridge	Pressure	Level switch	Outlet dia.
AHGS1	1-999S	1-999M	15mL/min	110VAC	25W	0.7 L	15MPa	Optional	Φ6 or Φ8
				220VAC					
				12, 24VDC					

## AHGS2 Progressive Type

Order code **AHGS-2-7-D-6-1**

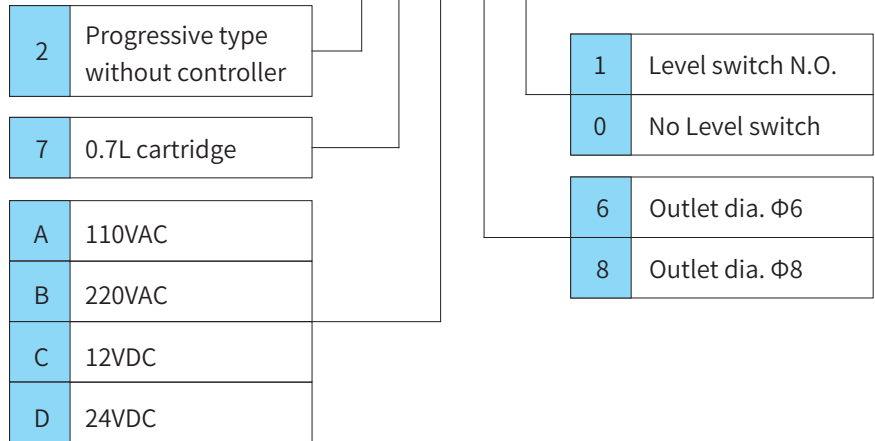

## Dimension

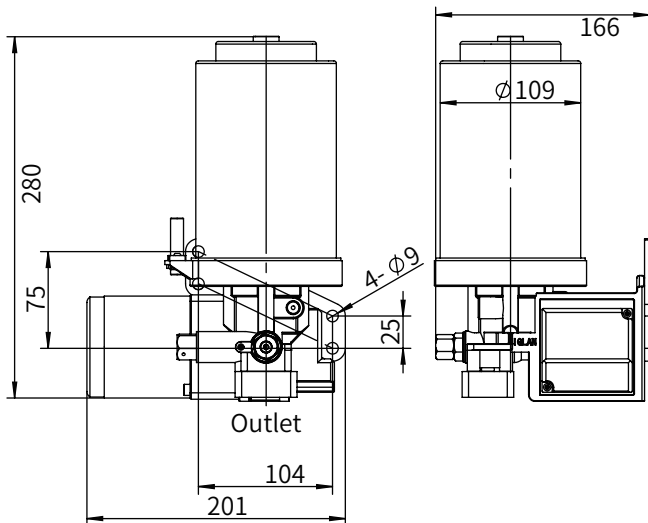

## Feature

1. The lubrication pump is controlled by the PLC or APC controller of the machine.
2. There is a pressure regulating valve to control the working pressure of the pump and protect its work safety.
3. A vent valve is provided to discharge the air in the pump cavity to ensure smooth discharge of the pump.
4. With pressure plate, vacuum driven lubricant suction..
5. Low-level transmitter can be installed.
6. After the lubricant in the cartridge is used up, it cannot be refilled. Ensure lubricant quality and avoid debris.
7. Matching distributor: ASV, ASVB, AVK, AVP series.
8. Lubricants: 000#, 00#, 0#, 1# lithium-based grease.

## Specification

Model	Lube time	Interval time	Discharge	Voltage	Power	Cartridge	Pressure	Level switch	Outlet dia.
AHGS2	PLC	PLC	15mL/min	110VAC	25W	0.7 L	15MPa	Optional	Φ6 or Φ8
				220VAC					
				12, 24VDC					

## AHGS3 Pressure-relief with Controller



Order code **AHGS-3-7-D-6-1**

3	Pressure relief type with controller	1	Level switch N.O.
7	0.7L cartridge	0	No Level switch
A	110VAC	6	Outlet dia $\Phi 6$
B	220VAC	8	Outlet dia $\Phi 8$
C	12VDC		
D	24VDC		

## Dimension

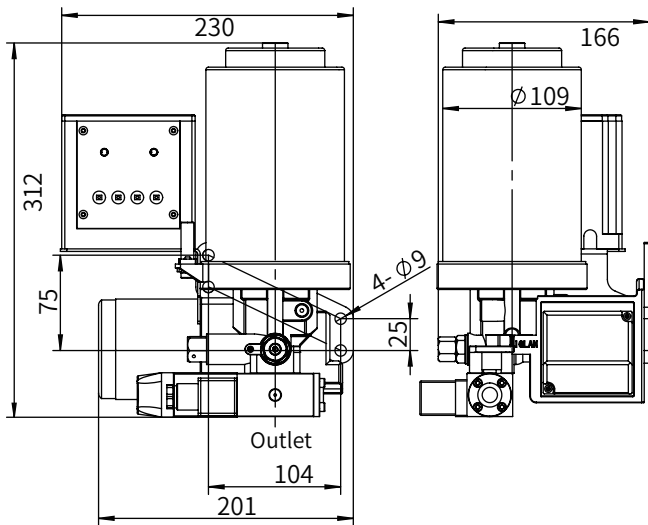

## Feature

1. The pump has its own controller to control the lubrication and interval time. It is easy to operate. It has a buzzer, and a warning sound will be issued when there is an abnormality.
2. There is a pressure regulating valve to control the working pressure of the pump and protect its work safety.
3. There is an electromagnetic pressure relief device, system will automatically release the pressure when the pump stop.
4. A vent valve is provided to discharge the air in the pump cavity to ensure smooth discharge of the pump.
5. With pressure plate, vacuum driven lubricant suction.
6. Low-level transmitter can be installed.
7. Optional pressure switch at the end of the lubrication system to monitor whether the main circuit of the lubrication system has interruptions, pressure loss, leakage, etc.
8. After the lubricant in the cartridge is used up, it cannot be refilled. Ensure lubricant quality and avoid debris.
9. Matching distributor: MG, MG2, MU series.
10. Lubricants: NLGI 000#, 00#, 0#, 1# lithium-based grease.

## Specification

Model	Lube time	Interval time	Discharge	Voltage	Power	Cartridge	Pressure	Level switch	Outlet dia.
AHGS3	1-999S	1-999M	15mL/min	110VAC	25W	0.7 L	8MPa	Optional	$\Phi 6$ or $\Phi 8$
				220VAC					
				12, 24VDC					

## AHGS4 Pressure-relief Type



Order code **AHGS-4-7-D-6-1**

4	Pressure relief type without controller	1	Level switch N.O.
7	0.7L cartridge	0	No Level switch
A	110VAC	6	Outlet dia. Φ6
B	220VAC	8	Outlet dia. Φ8
C	12VDC		
D	24VDC		

## Dimension

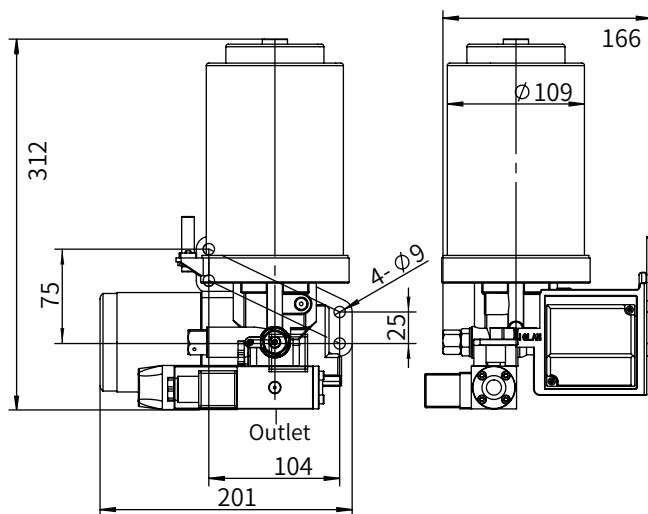

## Feature

1. The lubrication pump is controlled by the PLC or APC controller of the machine.
2. There is a pressure regulating valve to control the working pressure of the pump and protect its work safety.
3. There is an electromagnetic pressure relief device, system will automatically release the pressure when the pump stop.
4. A vent valve is provided to discharge the air in the pump cavity to ensure smooth discharge of the pump.
5. With pressure plate, vacuum driven lubricant suction..
6. Low-level transmitter can be installed.
7. Optional pressure switch at the end of the lubrication system to monitor whether the main circuit of the lubrication system has interruptions, pressure loss, leakage, etc.
8. After the lubricant in the cartridge is used up, it cannot be refilled. Ensure lubricant quality and avoid debris.
9. Matching distributor: MG, MG2, MU series.
10. Lubricants: NLGI 000#, 00#, 0#, 1# lithium-based grease.

## Specification

Model	Lube time	Interval time	Discharge	Voltage	Power	Cartridge	Pressure	Level switch	Outlet dia.
AHGS4	PLC	PLC	15mL/min	110VAC	25W	0.7 L	8MPa	Optional	Φ6 or Φ8
				220VAC					
				12, 24VDC					

## AHG1 Progressive with Controller



Order code **AHG-1-15-D-6-1**

1	Progressive type with controller	1	Level switch N.O.
15	1.5L reservoir	0	No Level switch
A	110VAC	6	Outlet dia. Φ6
B	220VAC	8	Outlet dia. Φ8
C	12VDC		
D	24VDC		

### Dimension

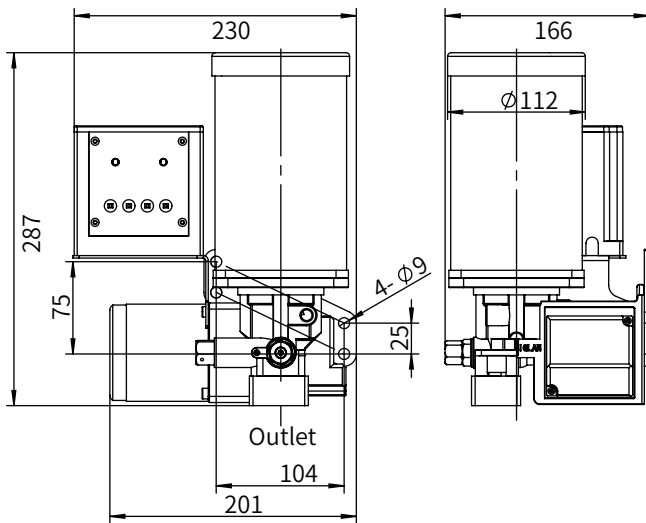

### Feature

1. The pump has its own controller to control the lubrication and interval time. It is easy to operate. It has a buzzer, and a warning sound will be issued when there is an abnormality.
2. There is a pressure regulating valve to control the working pressure of the pump and protect its work safety.
3. A vent valve is provided to discharge the air in the pump cavity to ensure smooth discharge of the pump.
4. With pressure plate, vacuum driven lubricant suction.
5. Low-level transmitter can be installed.
6. Refill reservoir with lubricant through filter. Please reduce impurities and air mixing into the lubrication system.
7. Matching distributor: ASV, ASVB, AVL, AVP series.
8. Lubricants: NLGI 000#, 00#, 0#, 1# lithium-based grease.

### Specification

Model	Lube time	Interval time	Discharge	Voltage	Power	Reservoir	Pressure	Level switch	Outlet dia.
AHG1	1-999S	1-999M	15mL/min	110VAC	25W	1.5 L	15MPa	Optional	Φ6 or Φ8
				220VAC					
				12, 24VDC					

## AHG2 Progressive Type



Order code **AHG-2-15-D-6-1**

2	Pressure relief type without controller	1	Level switch N.O.
15	1.5 L reservoir	0	No Level switch
A	110VAC	6	Outlet dia. Φ6
B	220VAC	8	Outlet dia. Φ8
C	12VDC		
D	24VDC		
E	3-phase 220VAC		
F	3-phase 380VAC		

## Dimension

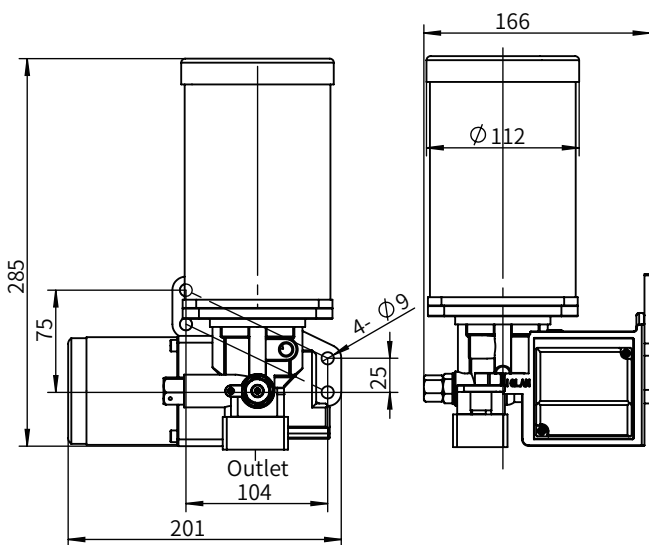

## Feature

1. The lubrication pump is controlled by the PLC or APC controller of the machine.
2. There is a pressure regulating valve to control the working pressure of the pump and protect its work safety.
3. A vent valve is provided to discharge the air in the pump cavity to ensure smooth discharge of the pump.
4. With pressure plate, vacuum driven lubricant suction..
5. Low-level transmitter can be installed.
6. Refill reservoir with lubricant through filter. Please reduce impurities and air mixing into the lubrication system.
7. Matching distributor: ASV, ASVB, AVL, AVP series.
8. Lubricants: NLGI 000#, 00#, 0#, 1# lithium-based grease.

## Specification

Model	Lube time	Interval time	Discharge	Voltage	Power	Reservoir	Pressure	Level switch	Outlet dia.
AHG2	PLC	PLC	15mL/min	110, 220VAC	25W	1.5 L	15MPa	Optional	Φ6 or Φ8
				12, 24VDC					
				3-phase 380V					

## AHG3 Pressure-relief with Controller



Order code **AHG-3-15-D-6-1**

3	Pressure relief type with controller	1	Level switch N.O.
15	1.5L reservoir	0	No Level switch
A	110VAC	6	Outlet dia Φ6
B	220VAC	8	Outlet dia Φ8
C	12VDC		
D	24VDC		

### Dimension

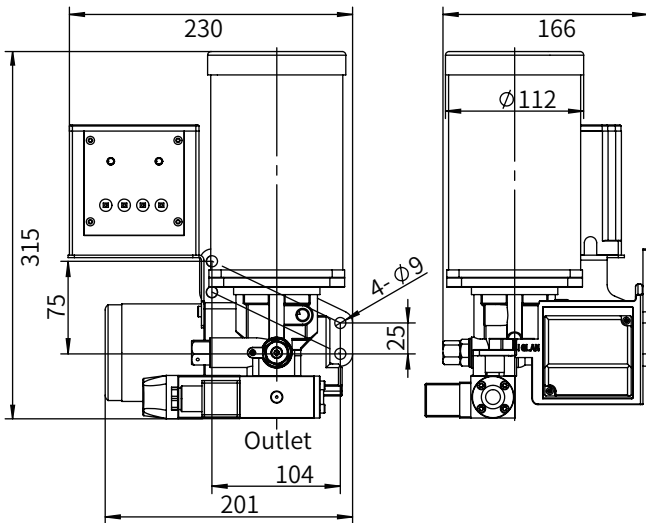

### Feature

1. The pump has its own controller to control the lubrication and interval time. It is easy to operate. It has a buzzer, and a warning sound will be issued when there is an abnormality.
2. There is a pressure regulating valve to control the working pressure of the pump and protect its work safety.
3. There is an electromagnetic pressure relief device, system will automatically release the pressure when the pump stop.
4. A vent valve is provided to discharge the air in the pump cavity to ensure smooth discharge of the pump.
5. With pressure plate, vacuum driven lubricant suction.
6. Low-level transmitter can be installed.
7. Optional pressure switch at the end of the lubrication system to monitor whether the main circuit of the lubrication system has interruptions, pressure loss, leakage, etc.
8. Refill reservoir with lubricant through filter. Please reduce impurities and air mixing into the lubrication system.
9. Matching distributor: MG, MG2, MU series.
10. Lubricants: NLGI 000#, 00#, 0#, 1# lithium-based grease.

### Specification

Model	Lube time	Interval time	Discharge	Voltage	Power	Reservoir	Pressure	Level switch	Outlet dia.
AHG3	1-999S	1-999M	15mL/min	110VAC	25W	1.5 L	8MPa	Optional	Φ6 or Φ8
				220VAC					
				12, 24VDC					



## AHG4 Pressure-relief Type



Order code **AHG-4-7-D-6-1**

4	Pressure relief type without controller	1	Level switch N.O.
15	1.5 L reservoir	0	No Level switch
A	110VAC	6	Outlet dia. Φ6
B	220VAC	8	Outlet dia. Φ8
C	12VDC		
D	24VDC		
E	3-phase 220VAC		
F	3-phase 380VAC		

## Dimension

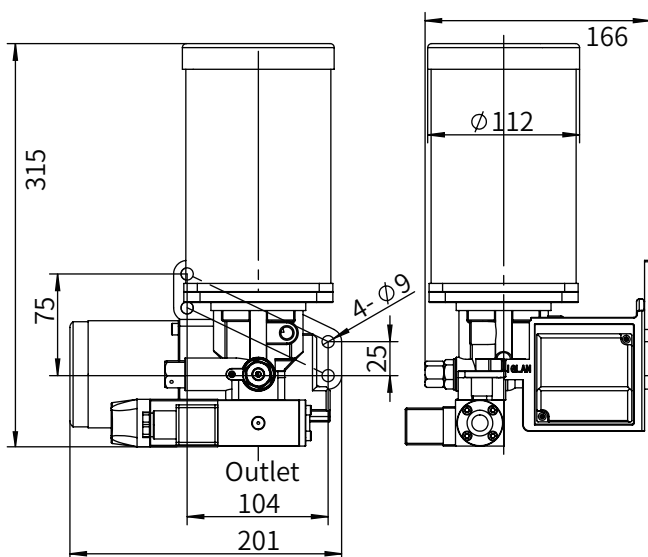

## Feature

1. The lubrication pump is controlled by the PLC or APC controller of the machine.
2. There is a pressure regulating valve to control the working pressure of the pump and protect its work safety.
3. There is an electromagnetic pressure relief device, system will automatically release the pressure when the pump stop.
4. A vent valve is provided to discharge the air in the pump cavity to ensure smooth discharge of the pump.
5. With pressure plate, vacuum driven lubricant suction..
6. Low-level transmitter can be installed.
7. Optional pressure switch at the end of the lubrication system to monitor whether the main circuit of the lubrication system has interruptions, pressure loss, leakage, etc.
8. Refill reservoir with lubricant through filter. Please reduce impurities and air mixing into the lubrication system.
9. Matching distributor: MG, MG2, MU series.
10. Lubricants: NLGI 000#, 00#, 0#, 1# lithium-based grease.

## Specification

Model	Lube time	Interval time	Discharge	Voltage	Power	Reservoir	Pressure	Level switch	Outlet dia.
AHG4	PLC	PLC	15mL/min	110, 220VAC	25W	1.5 L	8MPa	Optional	Φ6 or Φ8
				12, 24VDC					
				3-phase 380V					

## AGP Progressive Grease Pump



Ordercode **AGP-1-8-1-P-2-1-D**

1	With controller
2	No controller

2	2L reservoir
4	4L reservoir
6	6L reservoir
8	8L reservoir
10	10L reservoir

F	No pressure switch
N	Pressure switch N.C.

D	24VDC
B	220VAC

1	1 outlet
2	2 outlets

2	Discharge 2.5mL/min
4	Discharge 4.0mL/min

P	Pressure plate type
X	Stirring type

## Feature

The pressure plate type of the AGP progressive lubrication pump is pressurized by a tapered spring and can work in an inversion or rotation. This pump is equipped with a pressure switch, a controller, and a low oil level sensor, which can issue an alarm signal. AGP can be installed with 2 outlets, with external safety valve, the pressure can reach 35MPa, and it can form a progressive lubrication system with a progressive distributor. The pump is mainly used in large-scale automation equipment such as wind power and construction machinery.

## Principle

The motor drives the eccentric cam on the motor shaft to rotate, so that the plunger pump on the cam performs a reciprocating linear motion, thereby completing the two processes of suction and discharge. There is a one-way valve on the plunger pump, so that the discharged grease cannot flow back.

## Advantage

The pump with pressure plate has reliable sealing performance and can be installed in various equipments that perform rotary motion to ensure that sufficient lubrication quantity can be supplied to the lubrication points during the lubrication cycle at any angle. The lubrication pump can be equipped with up to two Relatively independent lubrication system.

## Specification

Model	Max Pressure	Discharge	Outlet thread	Temp. range	Lubricant	Voltage	Reservoir
AGP	35MPa	2.5mL/min 4.0mL/min	G1/4	-40 ~ +70°C	NLGI 000# to 3#	24VDC 220VAC	2/4/6/8/10L

Note: please choose antifreeze grease at low temperature.

## Progressive Grase Pump with Controller

### Details

- ① Input voltage
- ② Blocking signal output
- ③ Low level signal output
- ④ Safety valve
- ⑤ Outlet
- ⑥ Refill inlet
- ⑦ Controller



## Progressive Grase Pump without Controller

### Details

- ① Input voltage
- ② Blocking signal output
- ③ Low level signal output
- ④ Refill inlet
- ⑤ Safety valve
- ⑥ Outlet
- ⑦ PLC connection port



## AGP Dimension

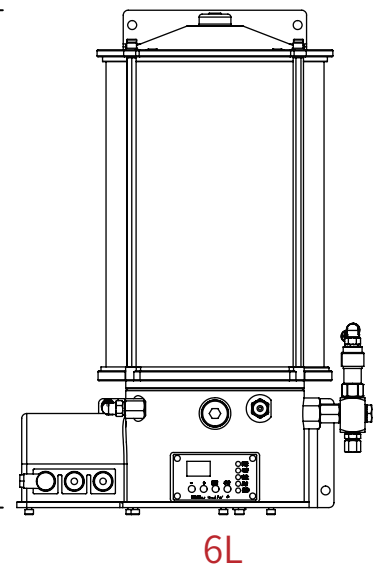
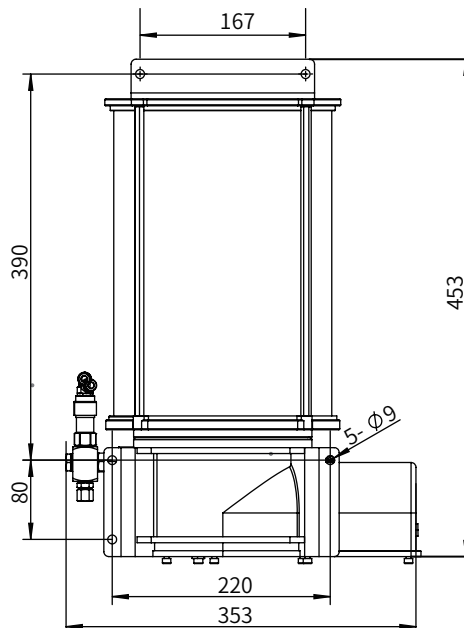
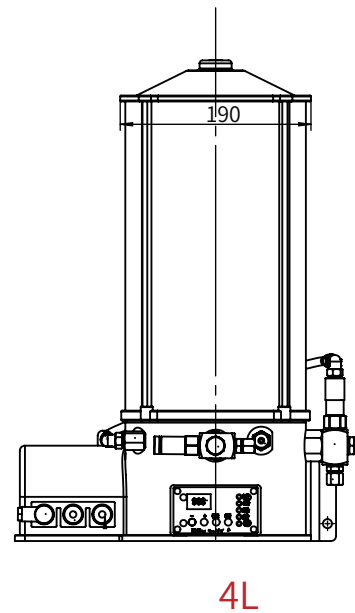
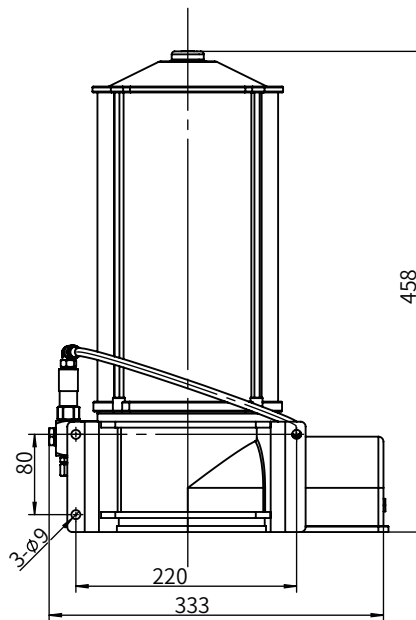
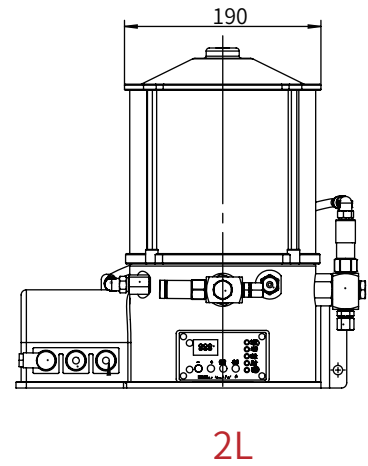
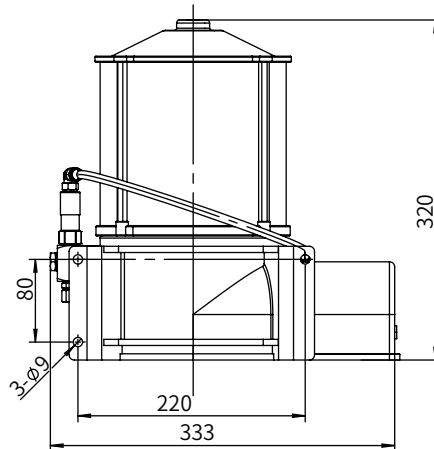

## AGP Dimension

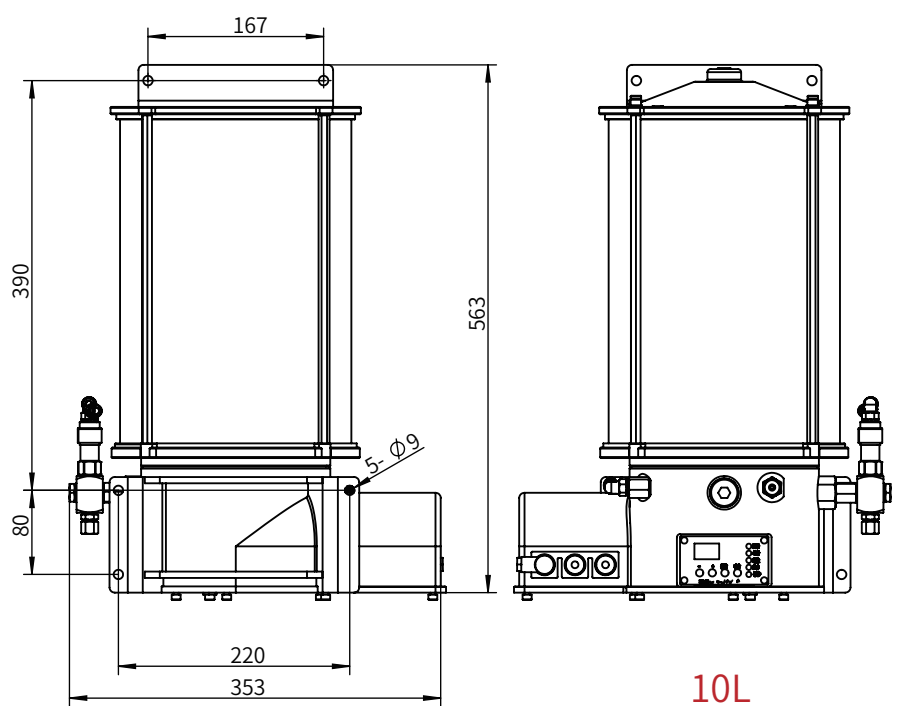
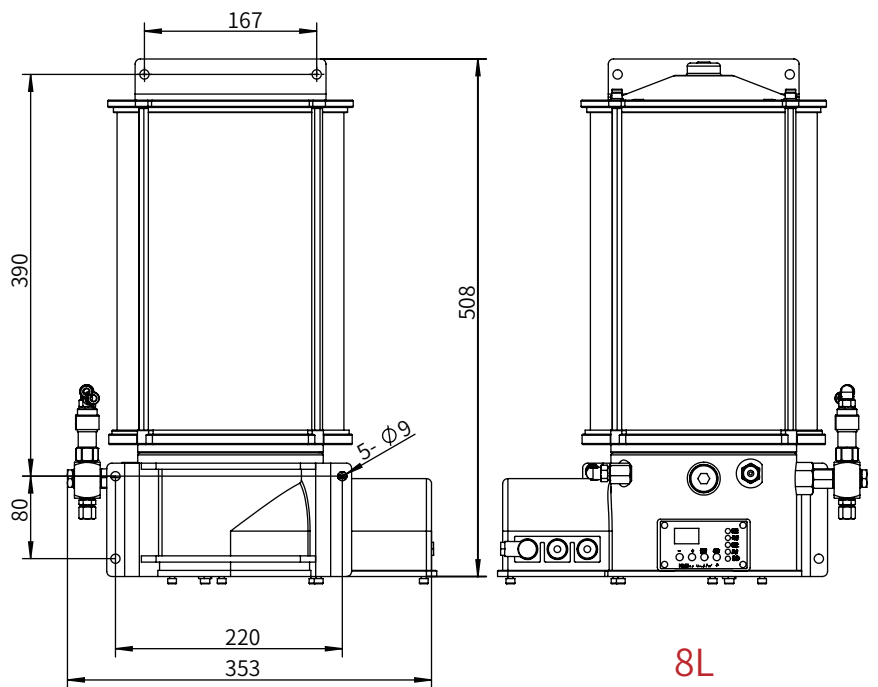



## AMG1 Resistance type with Controller



Ordercode **A M G - 1 - 3 - 0 - A - 0 - M**

1	Resistance type with controller	S	LUBE(sec); INT(sec)
3	3L reservoir	M	LUBE(sec); INT(min)
4	4L reservoir	H	LUBE(sec); INT(hour)
6	6L reservoir	N	LUBE(sec); INT(time)
8	8L reservoir	0	No level switch
20	20L reservoir	1	With level switch
0	No pressure switch	A	110 VAC
1	Pressure switch N.C.	B	220 VAC
		C	12 VDC
		D	24 VDC

## Feature

1. The pump has its own controller, LUB lubrication time: 1-999 seconds (minutes), INT interval time: 1-999 minutes (seconds/hours/times), special requirements can be customized.
2. The panel indicator light can display the lubrication and interval status of the lubrication pump.
3. The system can use the "RST" key to force lubrication or eliminate abnormal alarm signals.
4. The special alloy gear pump is matched with the induction motor, which has long service life and low noise.
5. The pressure relief device in the resistance system needs to be used with a proportional joint or a B-type distributor.
6. Equipped with an overflow valve to prevent the overloading of lubrication pump and the high pressure of the pipeline.
7. Lithium-based grease NLGI 000#~00#.

## Specification

Item Model	Motor Voltage (V)	Motor Power (W)	Lube Time (S)	Interval Time (M)	Working Pressure (MPa)	Max. Pressure (MPa)	Discharge (mL/min)	Outlet Diameter	Pressure Switch	Level Switch	Buzzer	Reservoir (L)	Weight (kg)
AMG1	AC110	40	1-999	1-999	3.5	4.5	300 500	6mm	Optional	Optional	Yes	3(Resin)	4.2
	AC220											4(Metal)	6.5
	DC12	25										6(Metal)	7.0
	DC24											8(Metal)	7.9

## AMG1 Dimension

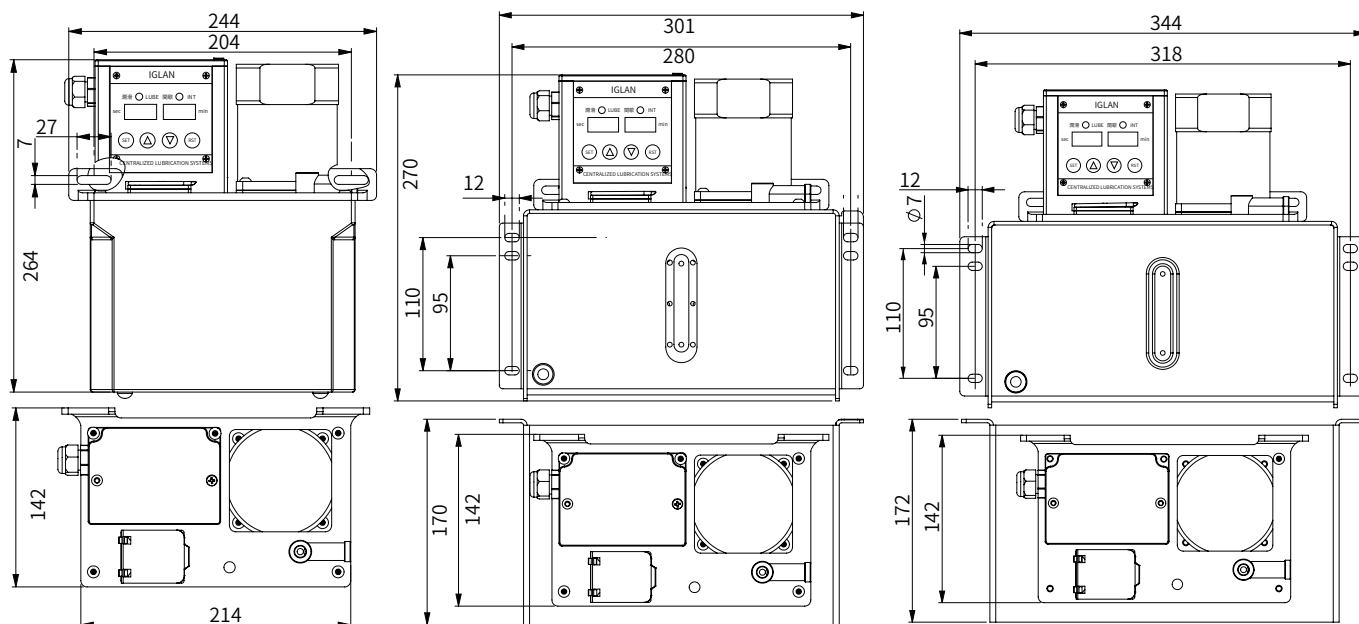

3L reservoir

4L reservoir

6L reservoir

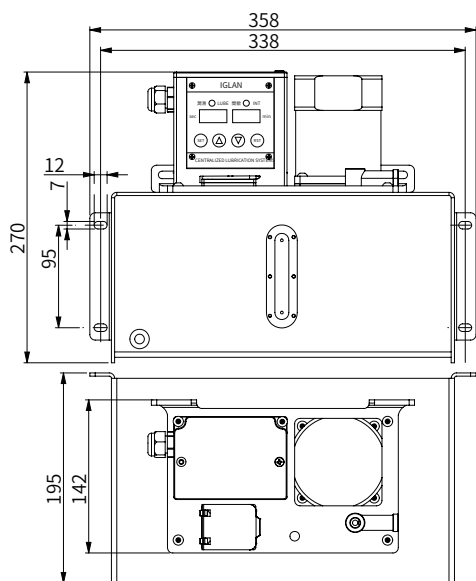

8L reservoir

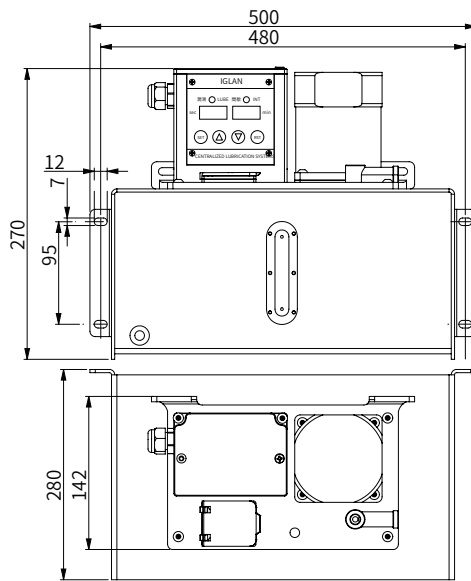

20L reservoir

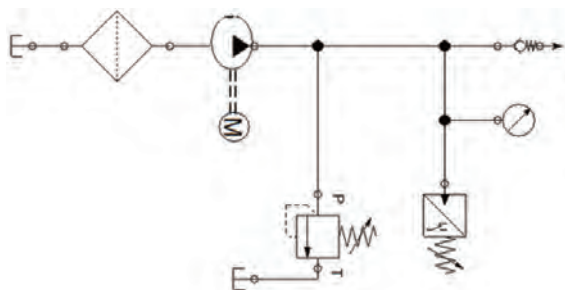

Circuit principle

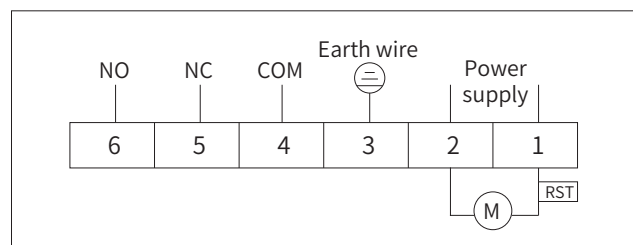

Wiring diagram



## AMG2 Resistance Type



Ordercode **AMG-2-3-0-A-1**

2	Resistance type without controller	1	Level switch N.C.
3	3L reservoir	2	Level switch N.O.
4	4L reservoir	A	110 VAC
6	6L reservoir	B	220 VAC
8	8L reservoir	C	12 VDC
20	20L reservoir	D	24 VDC
0	No pressure switch	E	3-phase 220 VAC
1	Pressure switch N.C.	F	3-phase 380 VAC
2	Pressure switch N.O.	G	3-phase 440 VAC
		H	3-phase 460 VAC

## Feature

1. The operation of the lubrication pump is controlled by the host PLC, working time and interval time.
2. The panel indicator light can display the lubrication status of the lubrication pump.
3. There is a "FEED" key in the system, which can be forced to lubricate.
4. The special alloy gear pump is matched with the induction motor, which has long service life and low noise.
5. The resistance system needs to be equipped with the B-type distributor or proportional connector.
6. The viscosity range of lithium grease is NLGI 000#~00#.

## Specification

Item Model	Motor Voltage (V)	Motor Power (W)	Lube Time (S)	Interval Time (M)	Working Pressure (MPa)	Max. Pressure (MPa)	Discharge (mL/min)	Outlet Diameter	Pressure Switch	Level Switch	Buzzer	Reservoir (L)	Weight (kg)
AMG2	110/220VAC 12/24VDC	25	PLC	PLC	3.5	4.5	300 500	6mm	Optional	Optional	No	3(Resin)	4.2
		25/40										4(Metal)	6.5
	3-phase 220 380/440/460											6(Metal)	7.0
												8(Metal)	7.9

## AMG2 Dimension

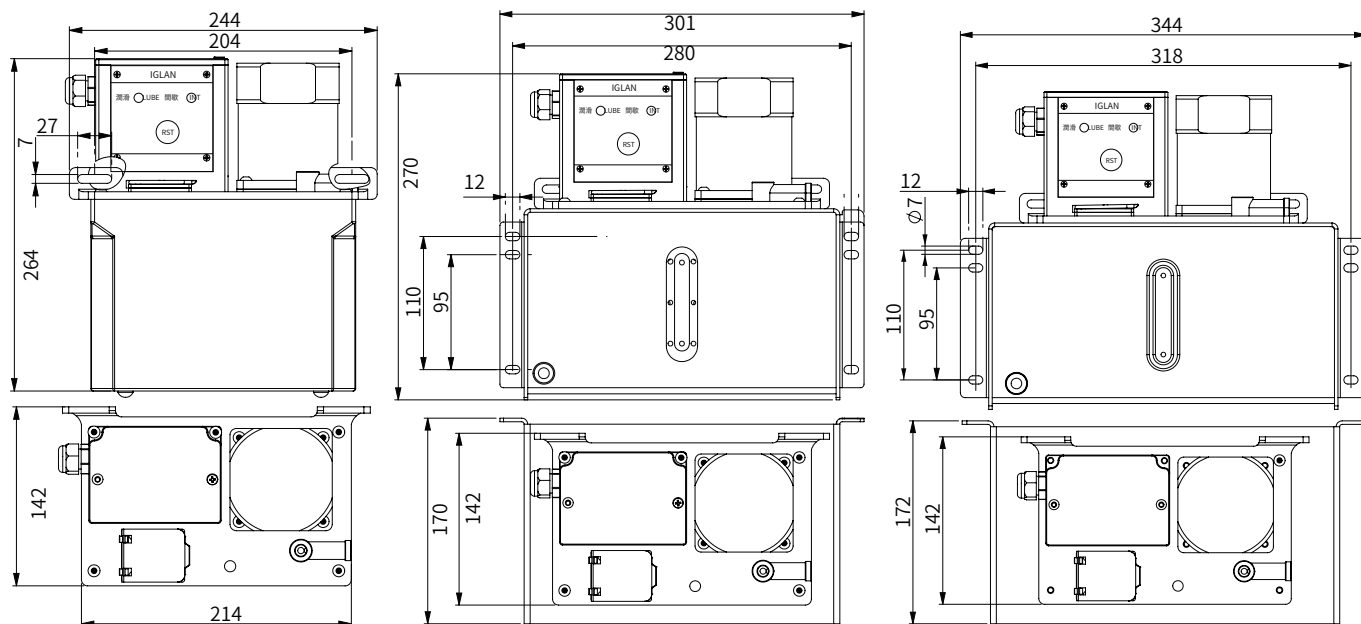

3L reservoir

4L reservoir

6L reservoir

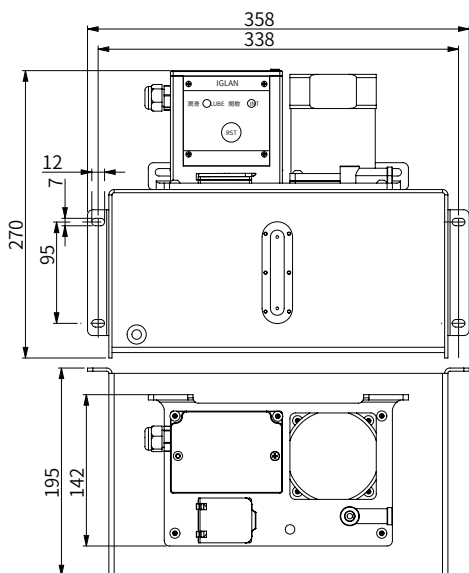

8L reservoir

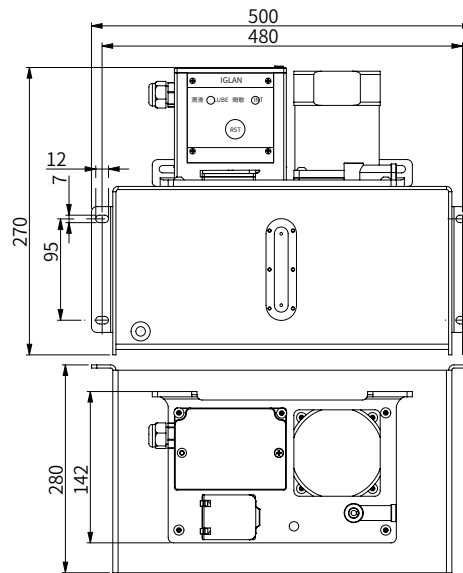

20L reservoir

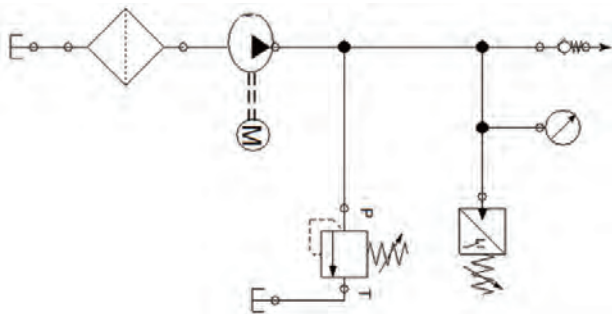

Circuit principle

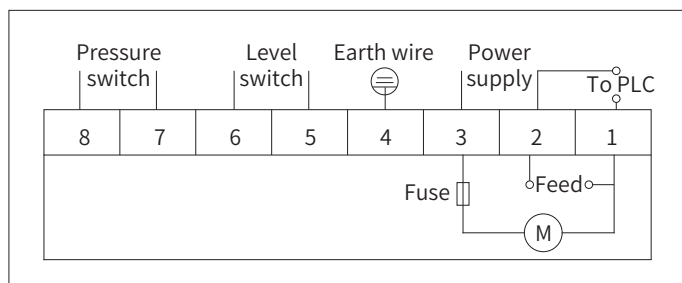

Wiring diagram

## AMG3 Pressure-relief with Controller



Ordercode **A M G - 3 - 3 - 0 - A - 0 - S**

3	Pressure-relief type with controller	S	LUBE(sec); INT(sec)
3	3L reservoir	M	LUBE(sec); INT(min)
4	4L reservoir	H	LUBE(sec); INT(hour)
6	6L reservoir	N	LUBE(sec); INT(time)
8	8L reservoir	0	No level switch
20	20L reservoir	1	With level switch
0	No pressure switch	A	110 VAC
1	Pressure switch N.C.	B	220 VAC
		C	12 VDC
		D	24 VDC

## Feature

1. Pump working time can be set, LUB lubrication time: 1-999 seconds (minutes), INT intermittent time: 1-999 minutes (seconds/hours/times), special requirements can be customized.
2. The panel indicator light can display the lubrication and intermittent status of the oiler.
3. The system can use the "RST" key to force lubrication or eliminate abnormal alarm signals.
4. There is a pressure relief device in the pressure relief system, which needs to be used with the MU/MG2/MG distributor.
5. Equipped with an overflow valve to prevent the pump from overloading and the line pressure from being too high.
6. The special alloy gear pump is matched with the induction motor, which has long service life and low noise.
7. Use oil range NLGI000#-00# lithium grease.

## Specification

Item Model	Motor Voltage (V)	Motor Power (W)	Lube Time (S)	Interval Time (M)	Working Pressure (MPa)	Max. Pressure (MPa)	Discharge (mL/min)	Outlet Diameter	Pressure Switch	Level Switch	Buzzer	Reservoir (L)	Weight (kg)
AMG3	AC110	40	1-999	1-999	3.5	4.5	250	6mm	Optional	Optional	Yes	3(Resin)	4.2
	AC220											4(Metal)	6.5
	DC12	25										6(Metal)	7.0
	DC24											8(Metal)	7.9

## AMG3 Dimension

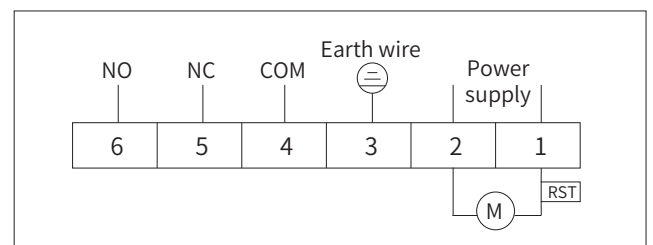
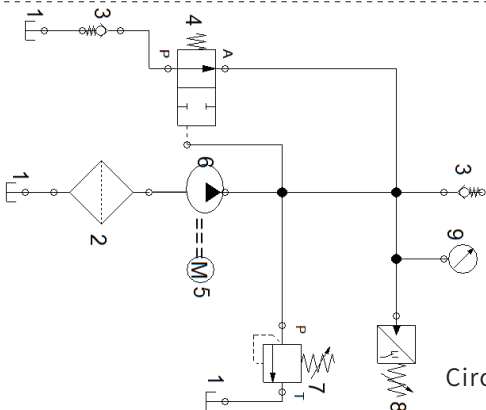
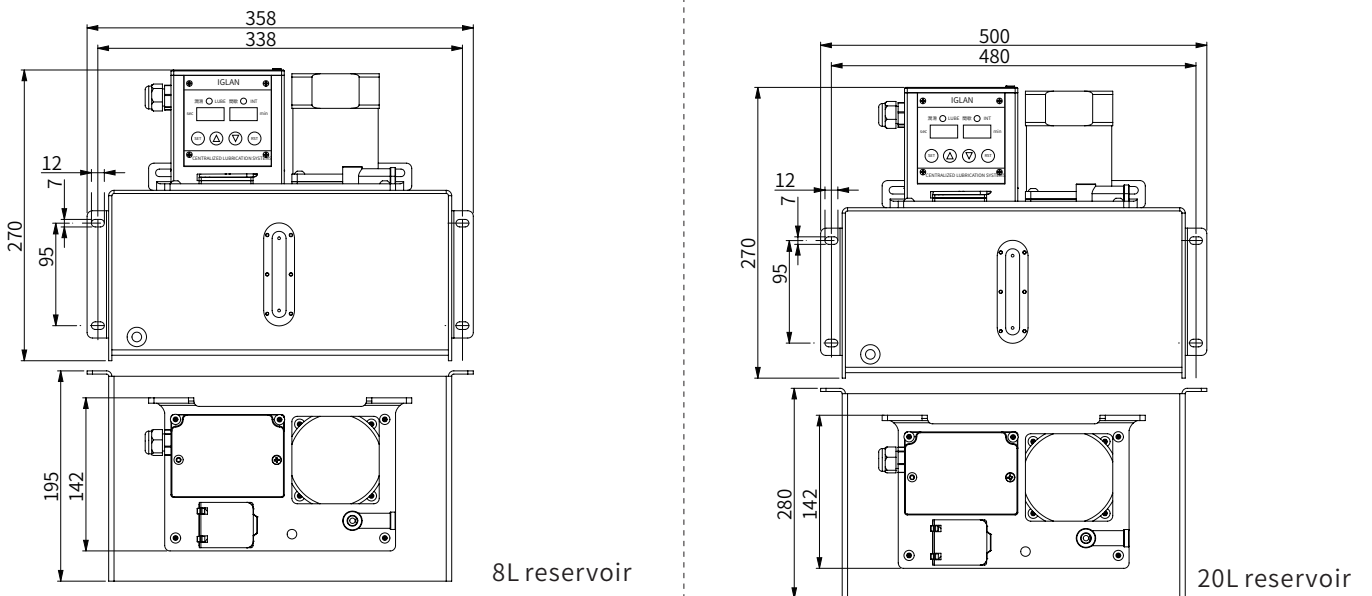
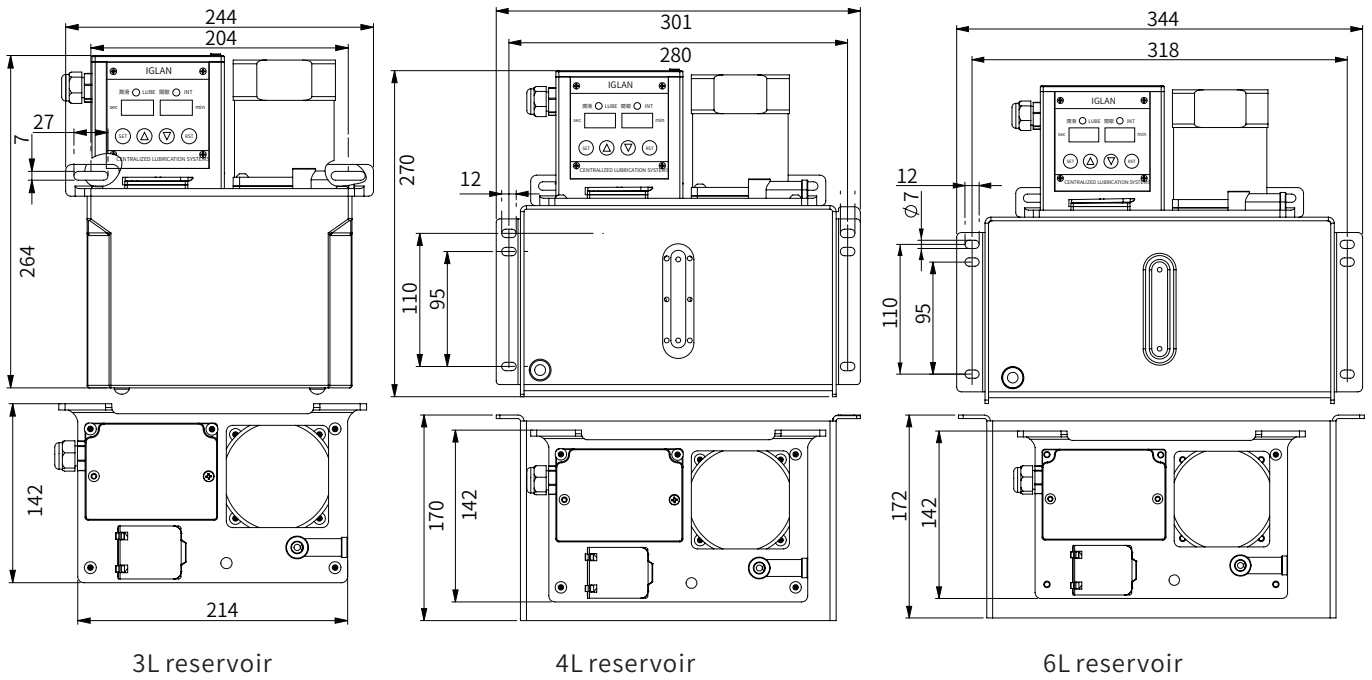

## AMG4 Pressure-relief Type



Ordercode **AMG-4-3-0-A-1**

4	Pressure-relief type without controller	0	No level switch
3	3L reservoir	1	With level switch
4	4L reservoir	A	110 VAC
6	6L reservoir	B	220 VAC
8	8L reservoir	C	12 VDC
20	20L reservoir	D	24 VDC
0	No pressure switch	E	3-phase 220 VAC
1	Pressure switch N.C.	F	3-phase 380 VAC
2	Pressure switch N.O.	G	3-phase 440 VAC
		H	3-phase 460 VAC

## Feature

1. The operation of the lubrication pump is controlled by the host PLC: working time and interval time
2. The panel indicator light can display the lubrication status of the lubrication pump.
3. There is a "FEED" key in the system, which can be forced to lubricate.
4. The special alloy gear pump is matched with the induction motor, which has long service life and low noise.
5. There is a decompression device in the volume system, which needs to be used with MU/MG2/MG distributor.
6. The range of oil products used is lithium base grease NLGI 000#~00#.

## Specification

Item Model	Motor Voltage (V)	Motor Power (W)	Lube Time (S)	Interval Time (M)	Working Pressure (MPa)	Max. Pressure (MPa)	Discharge (mL/min)	Outlet Diameter	Pressure Switch	Level Switch	Buzzer	Reservoir (L)	Weight (kg)	
AMG4	110/220VAC 12/24VDC	25	PLC	PLC	3.5	4.5	250	6mm	Optional	Optional	No	3(Resin)	4.2	
												4(Metal)	6.5	
	25/40	3-phase 220 380/440/460											6(Metal)	7.0
												8(Metal)	7.9	

## AMG4 Dimension

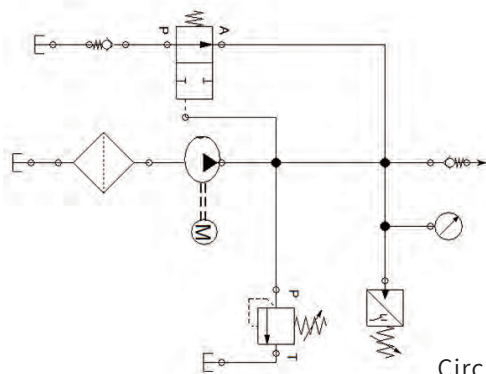
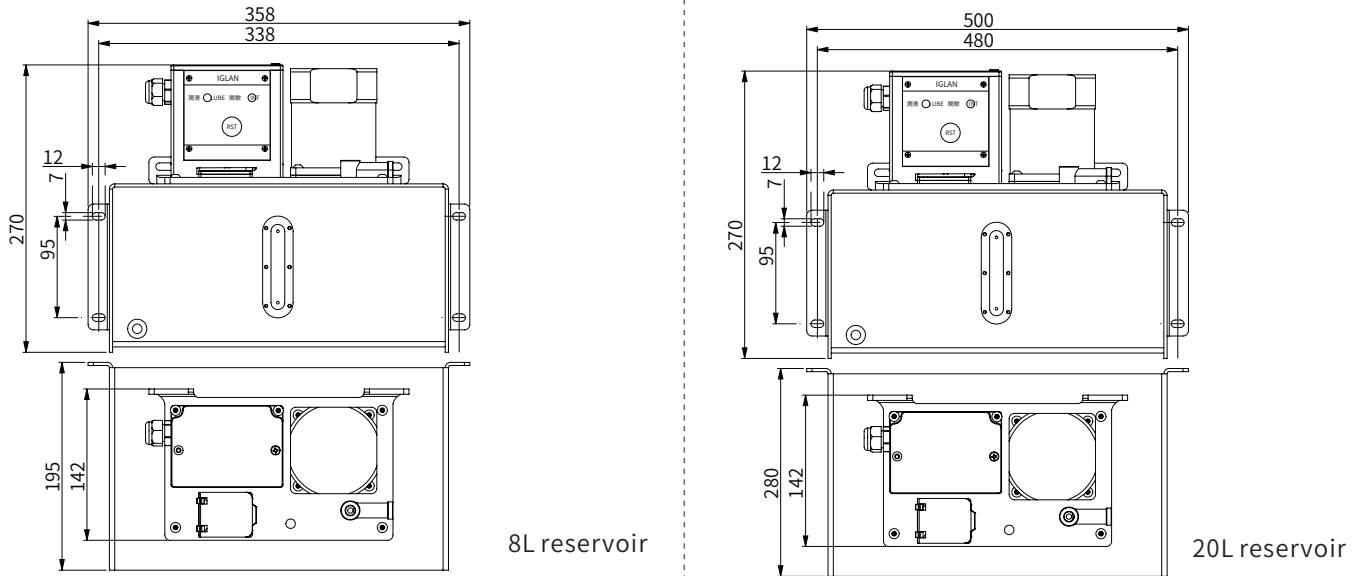
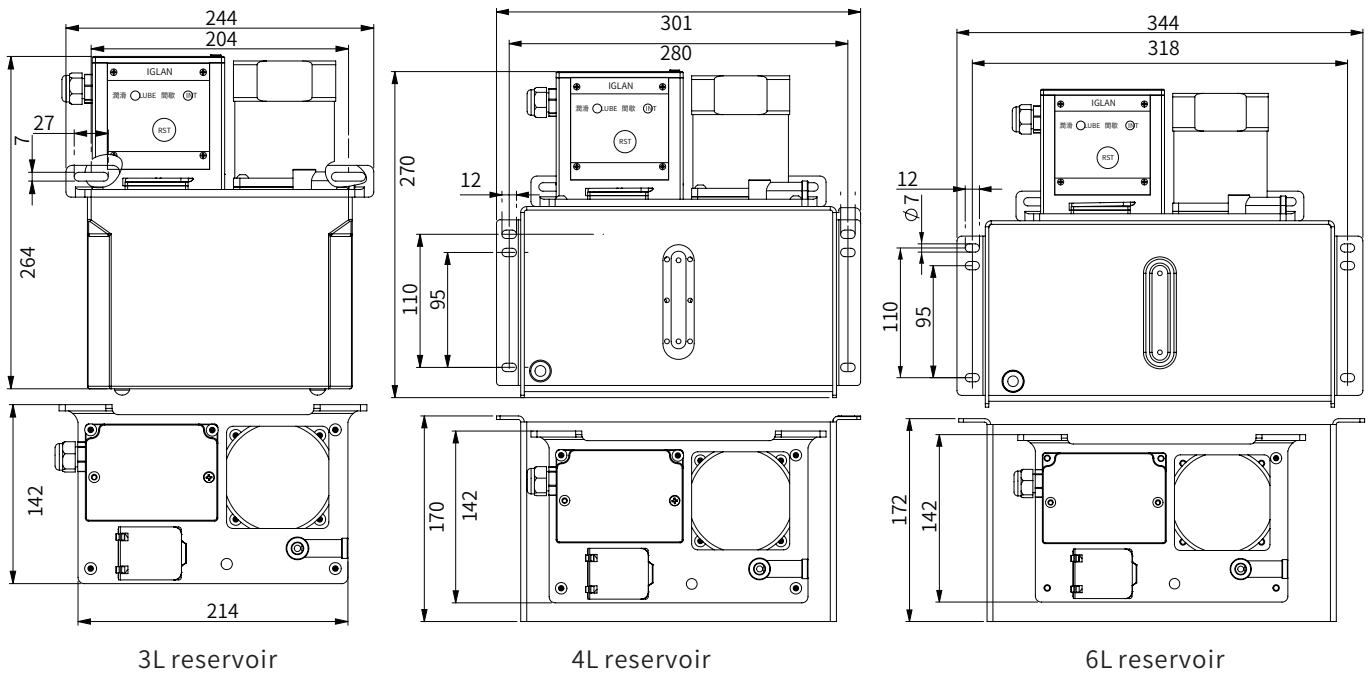

Circuit principle

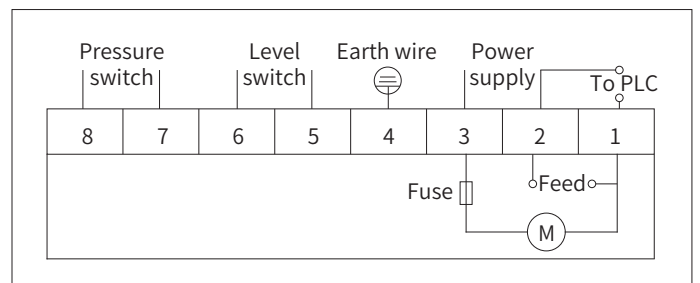

Wiring diagram

## P203 Multipoint Grease pump



Order code **P203-X-K-425-4-D-F**

P	Pressure plate		F	Level switch
X	Stirring type		N	No level switch
K	With controller		D	DC24V
N	No controller		B	AC220V
2	2.5mL/min	<p>Top view of outlets</p>	2	2L reservoir
4	4mL/min		4	4L reservoir
5	5mL/min		8	8L reservoir

### Feature

The pump adopts a special DC brushless motor (24VDC) and a gear reduction mechanism to drive the eccentric wheel, so that the plunger can reciprocate and complete grease suction and discharge process.

The pressure paddle is used to force the lubricant to suction port to improve grease suction efficiency, and grease in reservoir does not deposit. The pump is equipped with a low level signalling device.

Progressive lubrication systems can be formed through AVP, AVK, ASV and ASVB distributors.

The pump is equipped with a safety valve to prevent overloading of the working pressure. Pump protection class IP54.

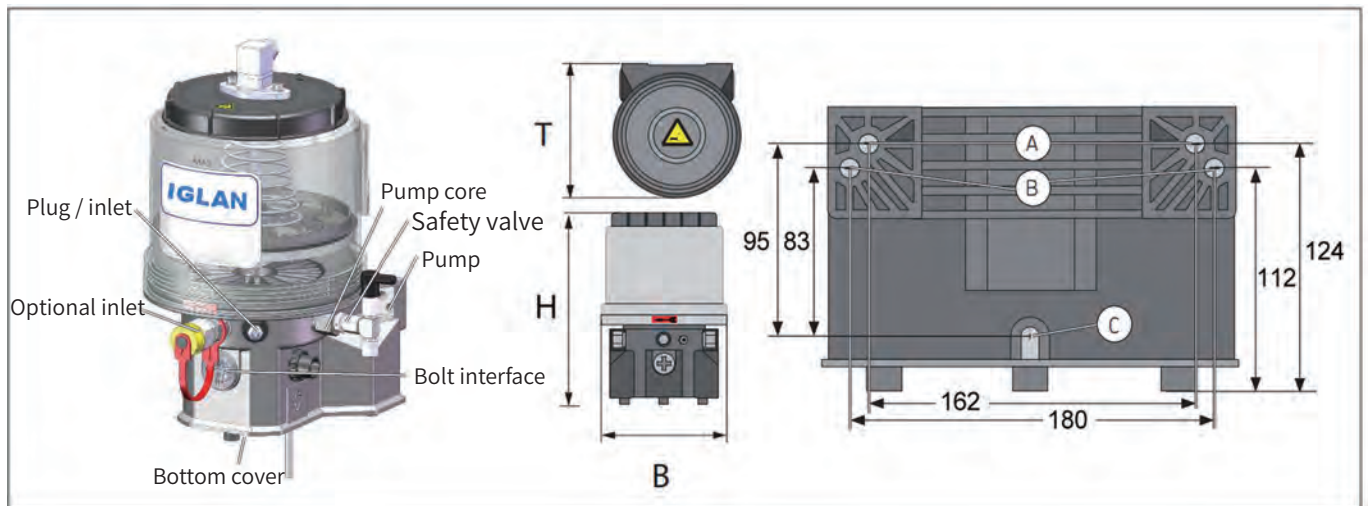

### Specification

Model	Reservoir	B	T	H	Pressure	Discharge	Outlets	Motor	Lubricants
P203X	2L	213	244	330	35MPa	2.5mL/min	1~3	24VDC/50W	NLGI 00#~2# -40°C~80°C
P203X	4L	230	250	355		4.0mL/min			
P203P	8L	230	250	465		5.0mL/min			



## AKM Grease Pump

### Feature

AKM lubrication pump is an electric grease pump with stable structure and powerful power, suitable for use in harsh working conditions. Selecting reducers with different speed ratios can achieve different discharges. The number of outlets is optional from one to six. Pumps can be equipped with large volume metal tanks or with explosion-proof motors. 380VAC, 15 liter metal tank version with PNP low level switch. The working time and interval time of the lubrication pump are controlled by an external PLC or timer.



### Specification

Rated pressure	30MPa
Reduction ratio	1: 25 (1~2 outlets), 1: 100 (3~6 outlets)
Rated current	1.6mL/min, 6.5mL/min, 10mL/min
Motor voltage	380VAC/90W, 220VAC/90W
Tank capacity	8L (PC tank), 15L (metal tank)
Outlet thread	Rp1/4, M10x1 (can be customized)
Lubricant range	NLGI 000# ~ 2#
Temperature range	-25°C ~ +60°C

### Order code

Code①	Code ②	Code ③	Code ④	Code ⑤	Code ⑥	Code ⑦
Voltage	Capacity	Outlets	Pump core	Level switch	Safety valve	Outlet joint
A = 110VAC	8 = 8L	1 = 1	K5	0 = none	N = none	0 = none
B = 220VAC	15 = 15L	2 = 2	K6	1 = NPN	Y = yes	6 = Φ 6
C = 380VAC		3 = 3	K7	2 = PNP	T =	8 = Φ 8
		.....			Y + piezometer	10 = Φ 10
		6 = 6				

# Electric Grease Pump

## AKM Dimension

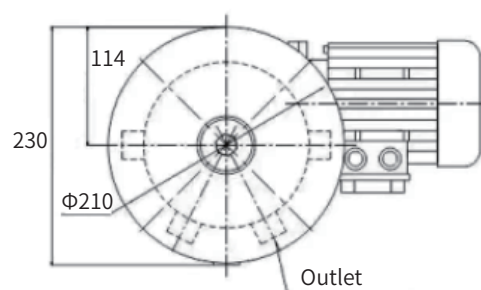
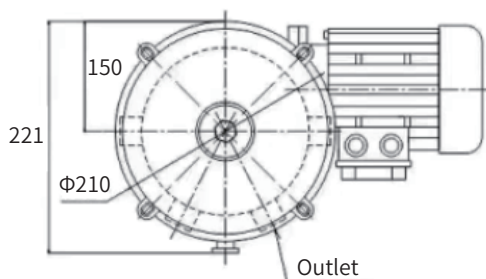
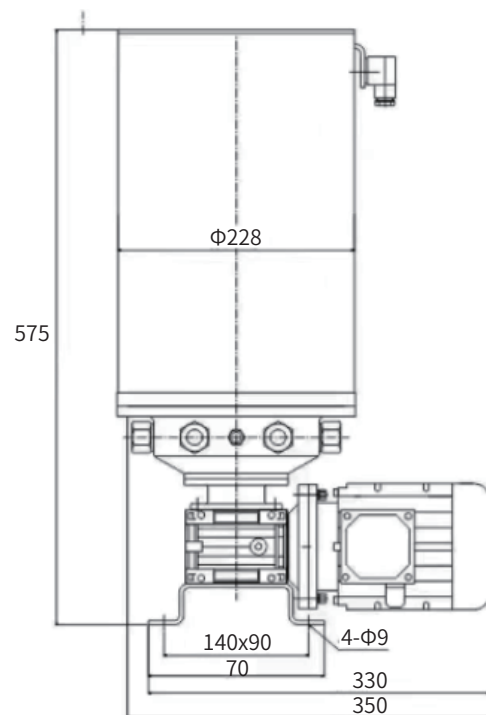
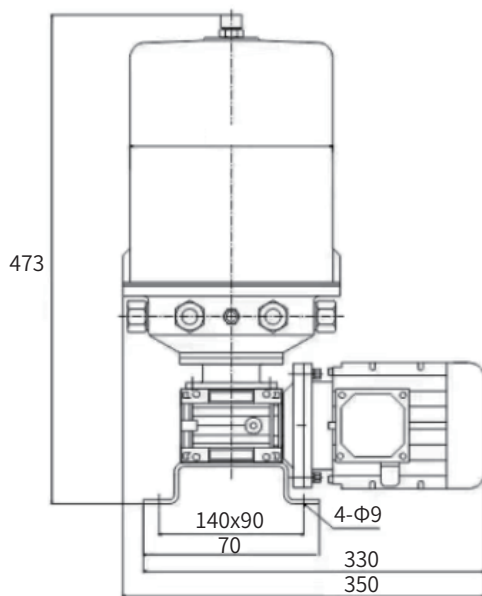

## DRB-Type

### Feature

DRB-P electric lubrication pump is suitable for single and double line grease lubrication systems with high frequency, long lines and dense lubrication points. It can be equipped with a mobile trolley, pipes, oil guns and cables to form a mobile lubrication system.

The lubrication pump is an electric high-pressure plunger type. The working pressure can be adjusted arbitrarily, with double overload protection. The reservoir has a liquid level alarm, and if the lubrication pump is equipped with an electrical control box, the centralized lubrication system can be fully automatically controlled and monitored.



### Order code

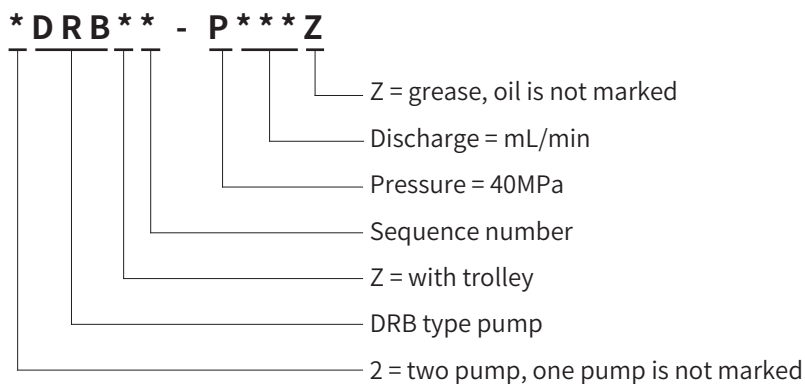

### Wiring diagram

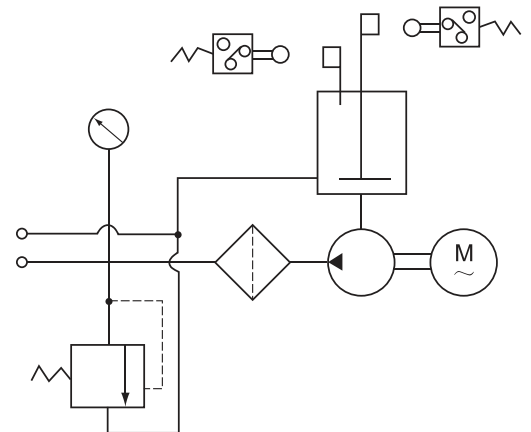

### Specification

Model	Discharge	Reservoir	Pressure	Power	Voltage	D	L	L1	H	H1	N.W
DRB1-P120Z	120mL/min	30L	40MPa	0.37kW	380V	310	500	233	760	1140	56kG
DRB2-P120Z	120mL/min	30L	40MPa	0.75kW	380V	310	563	233	760	1140	64kG
DRB3-P120Z	120mL/min	60L	40MPa	0.37kW	380V	400	500	278	810	1190	60kG
DRB4-P120Z	120mL/min	60L	40MPa	0.75kW	380V	400	563	278	810	1190	68kG
DRB5-P235Z	235mL/min	30L	40MPa	1.5kW	380V	310	575	233	760	1140	70kG
DRB6-P235Z	235mL/min	60L	40MPa	1.5kW	380V	400	575	278	810	1190	74kG
DRB7-P235Z	235mL/min	100L	40MPa	1.5kW	380V	500	575	328	920	1200	82kG
DRB8-P365Z	365mL/min	60L	40MPa	1.5kW	380V	400	575	278	810	1190	74kG
DRB9-P365Z	365mL/min	100L	40MPa	1.5kW	380V	500	575	238	920	1200	82kG

The range of lubricants used: lubricating grease NLGI 0~3#, lubricating oil > N68.

## Dimension

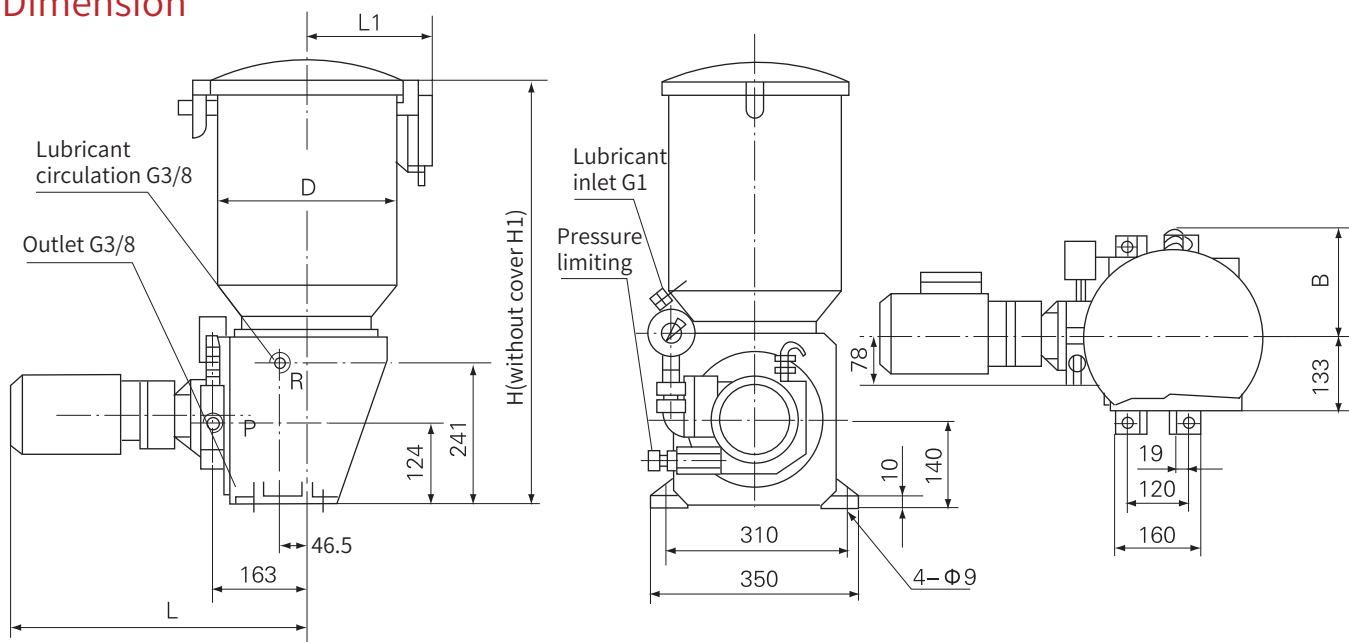

## Dimension with Trolley

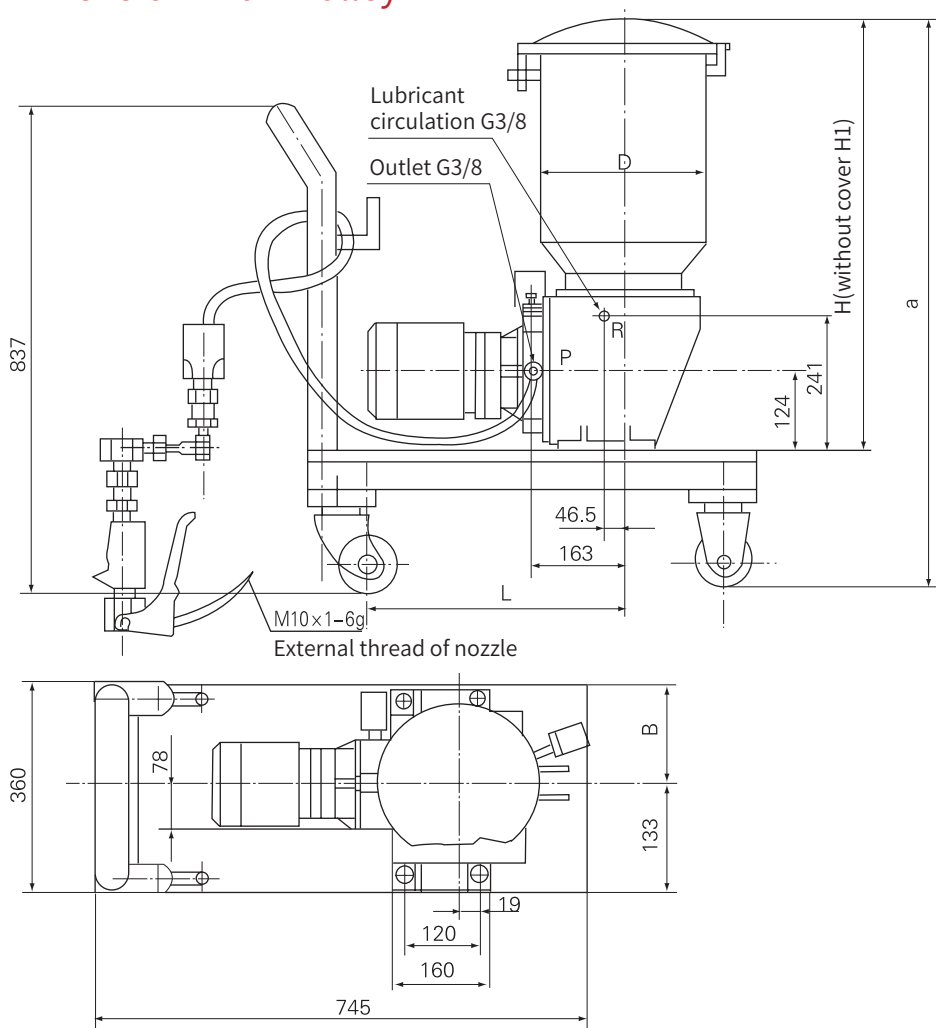

## MQL Minimal Quantity Lubrication Pump

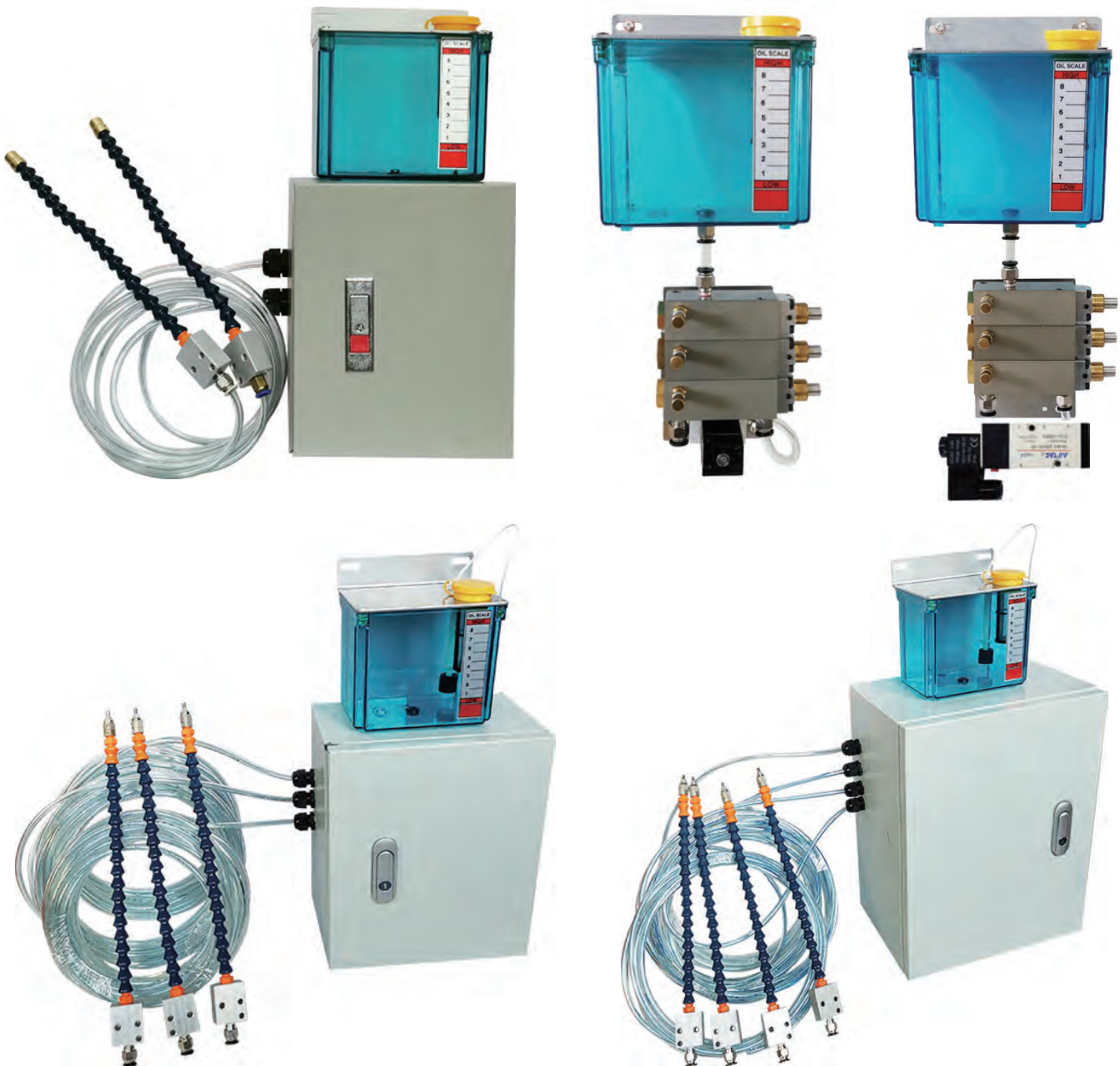

### Feature

MQL lubrication system is an external spraying minimum quantity lubrication system, which is used to replace the traditional water-soluble cutting fluid tool cooling lubrication system. The system is driven by a solenoid valve or a frequency generator. The mixture of air and liquid is atomized by high pressure and sprayed into the processing area, so that a small amount of oil is more evenly dispersed, the effect of lubricating and cooling is obtained, and the frictional heat generated by the tool and workpiece is eliminated. Because there is no waste of traditional cutting fluid to be disposed of, it is more environmentally friendly and more efficient.

## Minimum Quantity Lubrication System

### Feature

1. Improve production efficiency and effectively reduce production costs.
2. Basically keep room temperature, avoid tool size change, and prolong tool life by 1-2 times.
3. Reduce operating costs and eliminate the daily management and waste liquid treatment of traditional cutting fluids.
4. Improve the machining accuracy and reduce the surface roughness of the workpiece.
5. Reduce the amount of cutting oil, the amount used is 6mL~36mL/hour.
6. Realize dry cutting process, workpiece can be directly returned to the furnace without cleaning, reducing the process.
7. Lubricant is sprayed to the cutting edge without oil mist diffusion, which can be used in air-conditioned workshops.
8. The lubricant is extracted from plants, non-toxic and harmless, biodegradable, will not pollute the air, water and soil, and meets the ISO 14000 environmental protection standard.
9. Minimum quantity lubrication system can be added with control, detection and filtration according to needs of the site.

### Equipment

Sawing machines, lathes, milling machines, machining centers, gear machining, small rotary machines and other machine tools that use external cooling tools.

### Workpiece

It is suitable for the finishing and plate finishing of difficult-to-machine materials such as magnesium, copper, aluminum, free-cutting steel, medium-strength steel, etc.

### Specification

Model	Controller	Outlet dia.	Current	Air inlet dia.	Pressure	Discharge	Fixed hole
APOM-1	Pulse Valve	Φ6/Φ8	0A 0.1A	Φ8	4-8bar	0.01-0.09mL/cyc	60x90mm
APOM-2	Solenoid valve 110/220VAC, 24VDC	Φ6/Φ8 Tube-in-tube	0.1A 0.2A				

### Order code

<b>MQL</b>	<b>2</b>	<b>FC</b>	<b>2</b>	<b>3</b>	<b>T</b>	<b>F</b>
<b>Model</b>	<b>Reservoir</b>	<b>Control mode</b>	<b>Outlets</b>	<b>Tube</b>	<b>Spray nozzle</b>	<b>Level switch</b>
Minimum	03 = 0.3L	FH = Pulse valve + bracket	1 = 1 outlet	3~10meters	N = Non nozzle	F = Level switch
Quantity	05 = 0.5L	FC = Pulse valve + outer box	2 = 2 outlets		T = Flat nozzle	P = No level switch
Lubrication	10 = 1.0L	A = Solenoid valve 110V + box	3 = 3 outlets		50 = Long nozzle	
	20 = 2.0L	B = Solenoid valve 220V + box	4 = 4 outlets		E = 3-point nozzle	
		D = Solenoid valve 24V + box	5 = 5 outlets		U = U-shaped nozzle	



## MQL 1, 2 & 3-outlet Version with Bracket

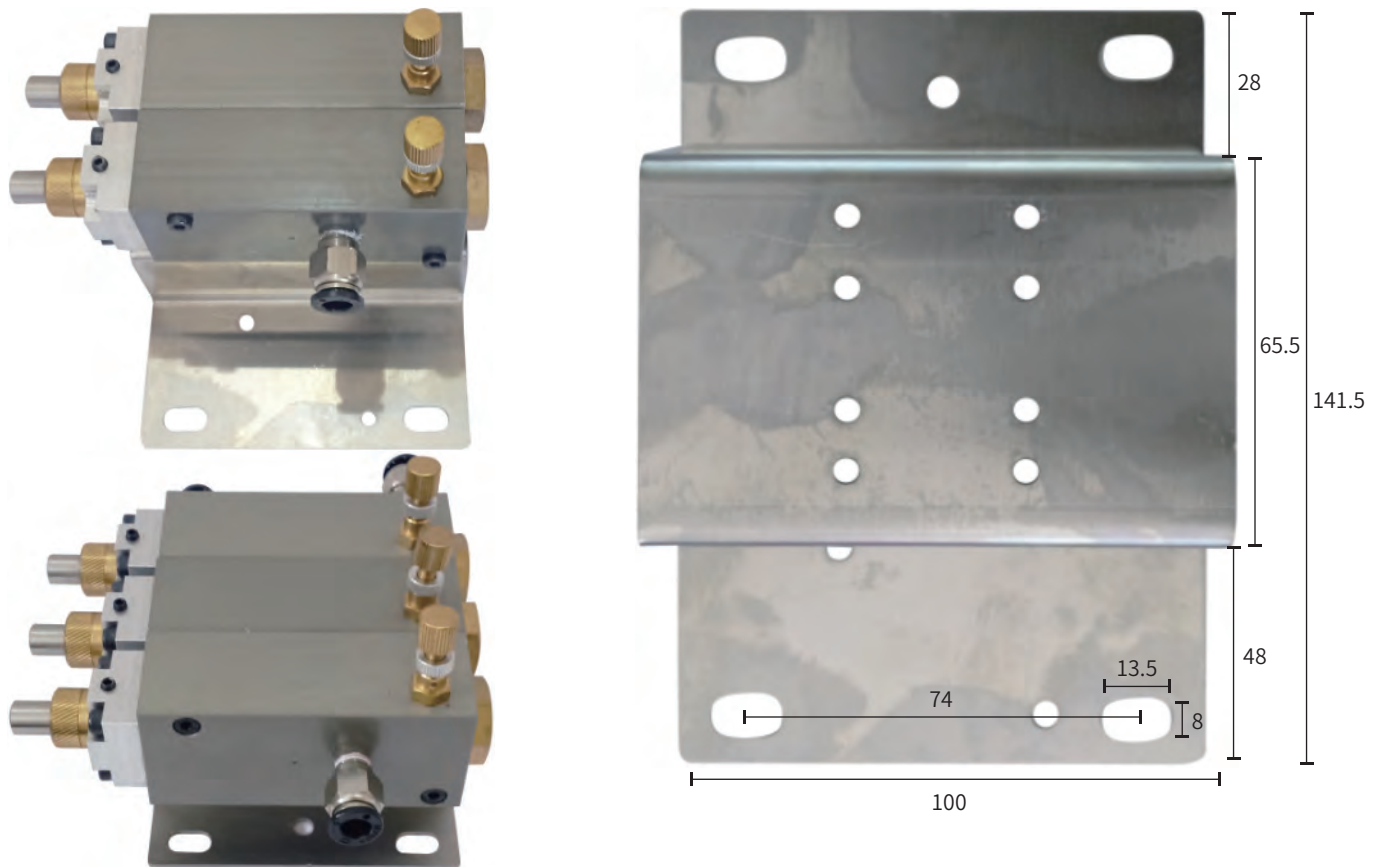

## MQL 2-outlet Version with Outer Box

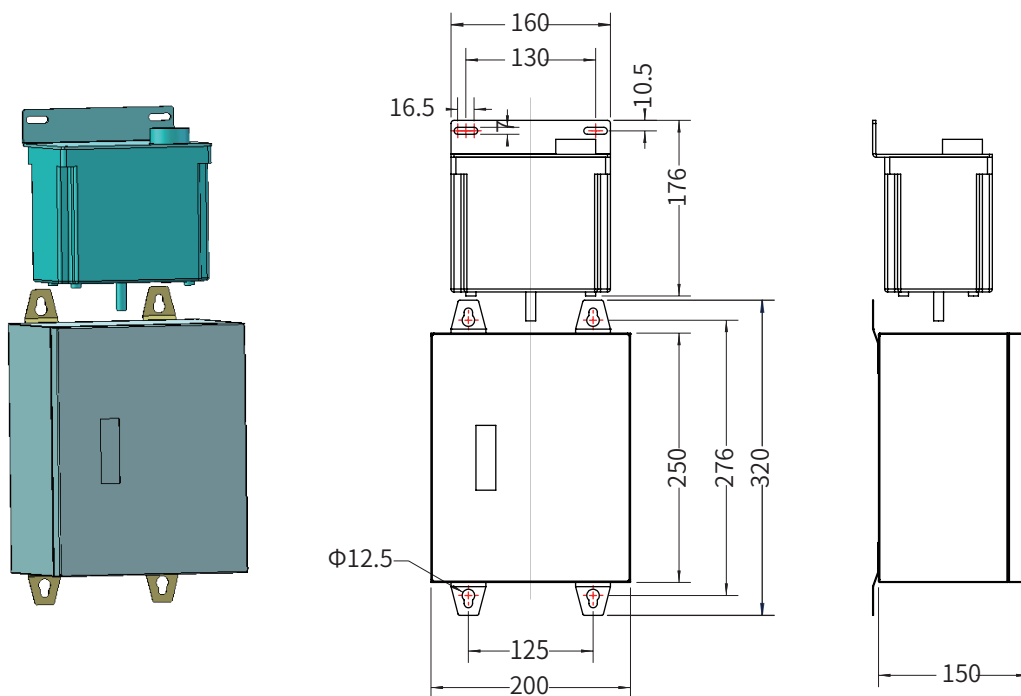



## MQL 3-outlet Version with Outer Box

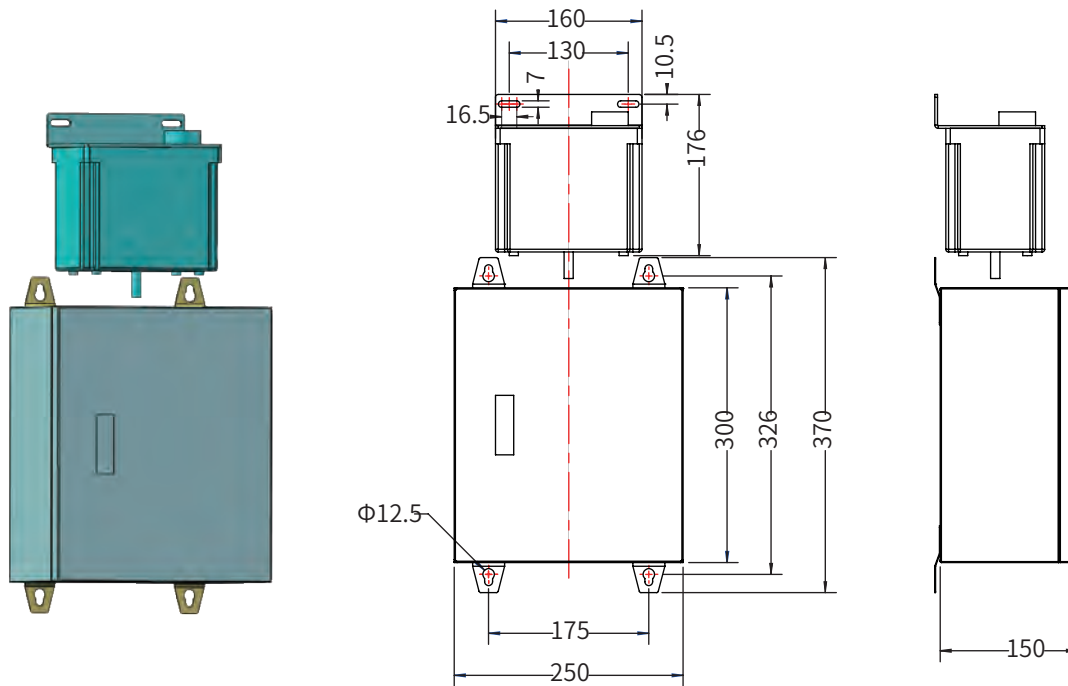

## MQL 4-outlet Version with Outer Box

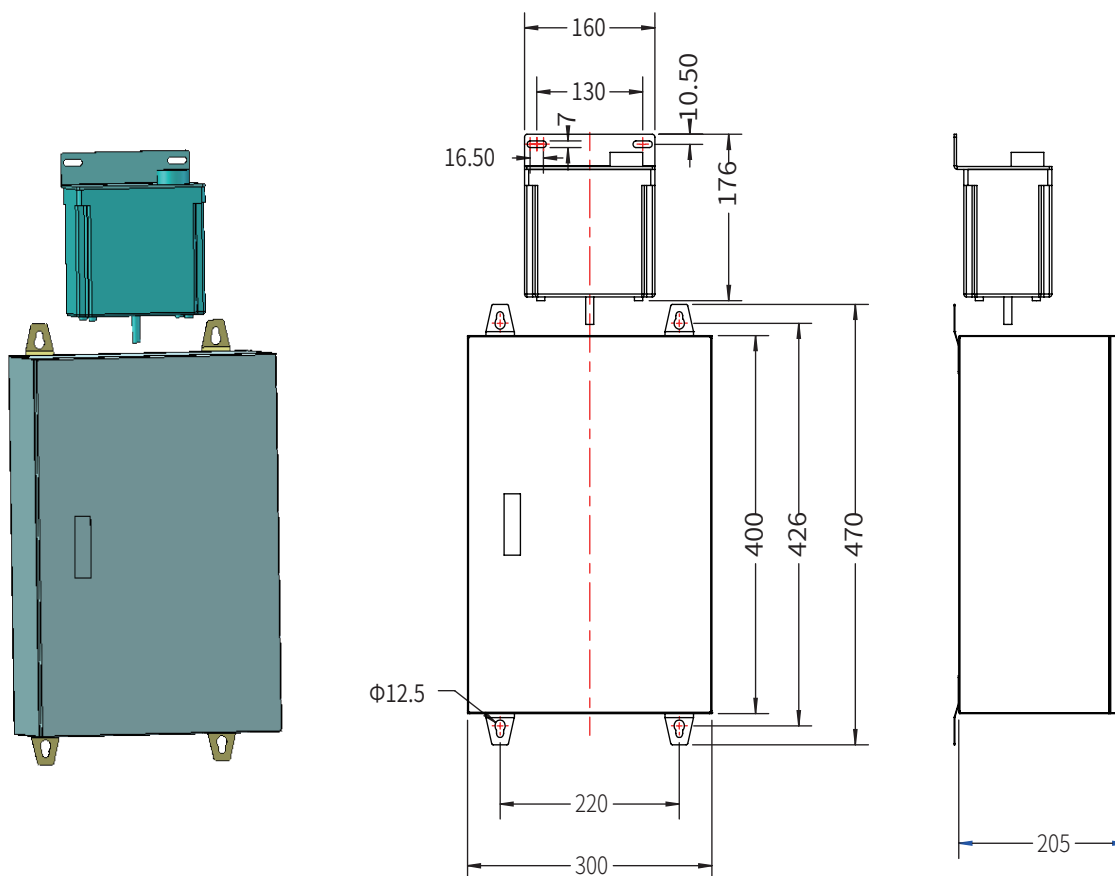

## SLM Automatic Single-point Lubricator



### Principle

There is an electrochemical generator on the top of the lubricator as the driving mechanism. The lubricator does not contain springs or other mechanical parts, and the lubricator is activated simply by adjusting the lube cycle time dial. The steady and growing gas generated in the generator pushes the piston, slowly squeezing out the lubricant. After that, the lubricator has been working automatically within the set lubrication cycle.

### Specification

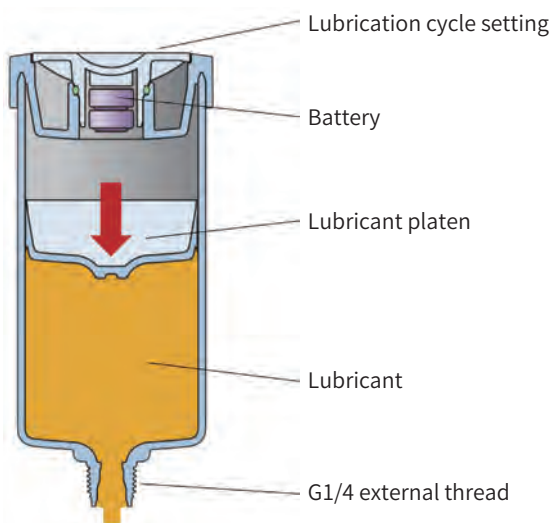

Model	Capacity	Drive type	Temperature range
SLM-120	120mL	Pneumatic	-20~60°C(suitable lubricant)
Model	IP Grade	Connection	Lubricants
SLM-120	IP65	G1/4	Oil or grease below NLGI 2
Model	Pressure	Working time	Dimension
SLM-120	Max. 5.5bar	1/3/6/9/12 months	Dia. 55mm, height 118mm

Note: Lubricator with grease is 185g, and without grease is 85g. SLM series single-point lubricators are disposable and cannot be refilled.

## GP Adjustable Single-point Lubricator

### Feature

1. Discharge can be adjusted depends on actual demand.
2. The lubricant grade is NLGI 0~3#, which can be refilled.
3. It can be waterproof, dustproof and cold resistant, and the temperature range is -20°C~125°C.
4. It is applied to single-point lube such as bearing and linear slide.

### Specification

Model	Spec	Capacity(g)
GP-26C	Height 120 x Φ55	78
GP-36C	Height 135 x Φ68	150



## SPM Automatic Single-point Lubricator

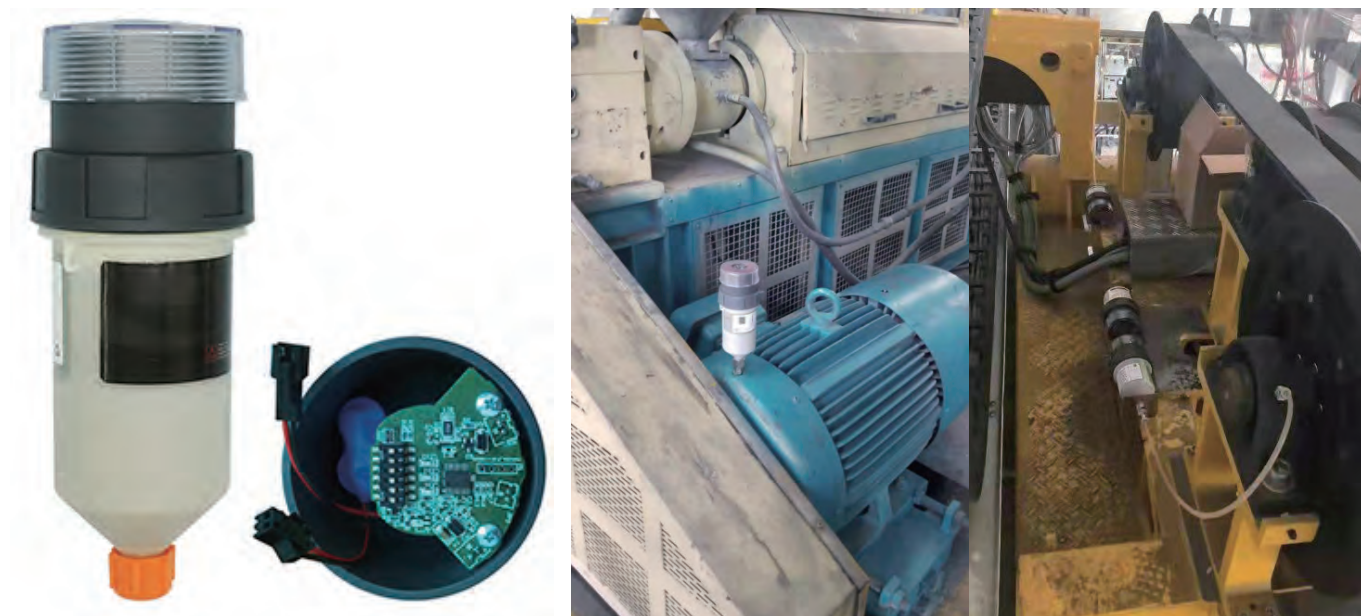

### Feature

1. The SPM series is suitable for applications in large temperature changes, direct installation, long-distance installation, vibrating machines, limited space or dangerous environments within
2. The metering volume speed is not affected by temperature.
3. The maximum lubrication pressure during the whole working period is 12bar.
4. Various lubrication cycles can be set.
5. Lubricant can be refilled when used up.
6. The translucent reservoir can visually check the remaining amount of lubricant.
7. The red-yellow-blue LED indicator shows the status of the lubricator.
8. The external power supply version can be linked with the start and stop of the device power supply.
9. Users can choose the version without grease, and lubricant for the initial filling can be determined according to the user's requirements, but it must be within the viscosity grade.

### Specification

Model	Capacity	Repeat fill times	Lubricant grade	Operating temperature	Work pressure
SPM-125	125mL (refillable)	Max. 10 times Seal is getting weaker	Oil or grease below NLGI 2#	-20°C to +60°C	Up to 12bar
SPM-250	250mL (refillable)				
Model	Dimension	Power supply	Working time	Battery Life	Connection
SPM-125	82mm x 178mm	3V lithium battery or 6V external power	0.5/1/3/6/9/12 months	Enough to discharge 250mL lubricant	Thread R1/2
SPM-250	82mm x 225mm				

## LA Oil Hand Pump

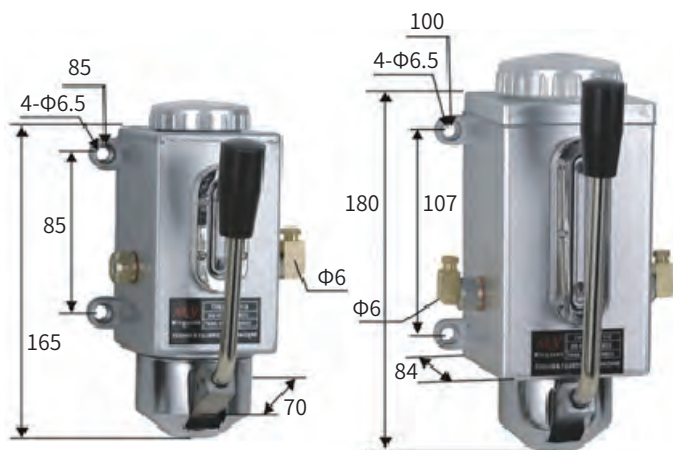

LA-8

### Feature

1. Volume of oil tank LA-6 (350mL) and LA-8 (600mL).
2. Low cost, high practicality.
3. Easy to be operated by pushing handle down for oil discharging.
4. Small discharge volume and easy to mounting.
5. It's equipped with reverse stopper that prevents the back-flow of oil.
6. Left outlet, right outlet, left and right double outlets.

Model	Discharge	Pressure	Capacity	L	W	H	Viscosity	Weight	Bolt center	Diameter	Outlets
LA-6	8mL/cyc	15bar	350cc	112	134	134	32-68cSt@40°C	1.2kg	85mm	4mm	1
											2
LA-8	8mL/cyc	15bar	600cc	124	138	138	32-68cSt@40°C	1.4kg	85mm	6mm	1
											2
LA-8	8mL/cyc	15bar	600cc	124	138	138	32-68cSt@40°C	1.4kg	100mm	4mm	1
											2
LA-8	8mL/cyc	15bar	600cc	124	138	138	32-68cSt@40°C	1.4kg	110mm	6mm	1
											2

## TA Oil Hand Pump

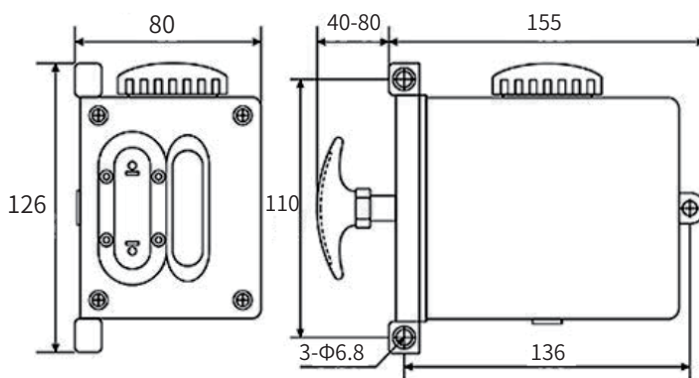

LA-8 dimension

Model	Fixed hole	Length	Width	Height	Capacity	Outlet	Weight	Discharge	Pressure	Viscosity
TA-3	56mm	117	70	126	180mL	Φ4, Φ6	0.5kg	8mL/cyc	3.5 bar	32-68cSt@40°C
TA-8 left	110mm	186	80	126	650mL	Φ4	1.0kg			
TA-8 right	136mm	186	80	126	650mL	Φ4	1.1kg			

## HP Oil Hand Pump



HP-5L (Left type)



HP-5M (middle type)



HP-5R (right type)

### Feature

1. The standard capacity is 600mL, and another large capacity is 2000mL.
2. Left type, right type and middle type, diameters 4mm and 6mm optional.
3. The cost is economical, the applicable machinery and equipment are diverse, and the practicability is high.
4. It is easy to operate by repeatedly operating the handle to deliver oil.
5. Small size and easy installation.
6. There is a non-return device to prevent the backflow of lubricating oil.

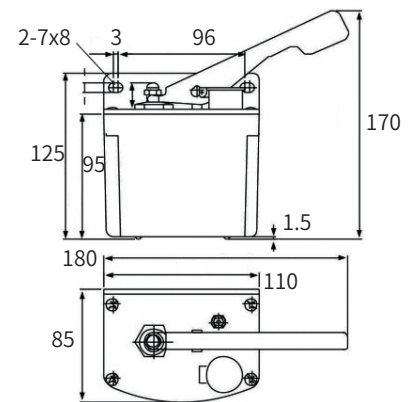

Model	Type	Pressure	Capacity	Diameter	Bolt center	Length	Width	Height	Viscosity	Weight	Discharge
HP-5L	Left	5 bar	600mL	Φ4	96mm	110mm	85mm	170mm	32-68cSt@40°C	8kg	5mL
HP-5R	Right										
HP-5M	Middle										

## XETP20 Oil & Grease Hand Pump

### Feature

1. Suitable for all kinds of oil and grease lubricants.
2. Insert the dosing pump into the standard 15kg barrel of commercial lubricant for operation.
3. Easy to carry, easy to operate and widely used.
4. By default, it is equipped with 1.5m hose and quick plug.
5. Lubricant: NLGI 000~2# lithium grease, N22~N320 oil.
6. Operating ambient temperature: -20~+80 °C.

### Specification

Model	Connection	Discharge	Pressure
SJC50Z	Nylon pipe quick plug	50mL/cyc	1.5Mpa
SJC50ZA	Rubber tube quick plug		

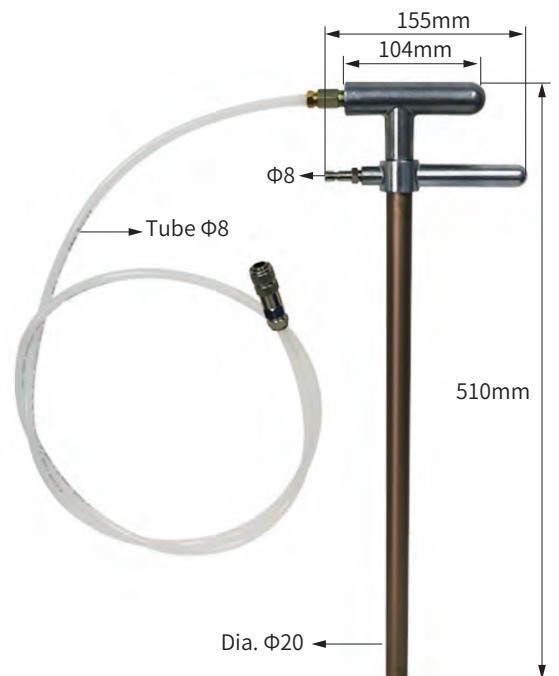



## EGH Pressure-relief Grease Pump



Order code

**EGH-4C-R-6**

EGH	Pressure relief Type	6	Outlet Φ6
4C	0.4L cartridge	8	Outlet Φ8
3P	0.3L reservoir	L	Left outlet
8P	0.8L reservoir	R	Right outlet
		T	Double outlet



### Feature

1. After the grease in the cartridge is used up, it cannot be refilled. Please use the recommended grease.
2. Do not use grease containing molybdenum disulfide.
3. Use lithium-based grease, if non-lithium grease must be used, please contact us.
4. Do not use any grease that will corrode brass or rubber substances.
5. The grease must be injected from the filler nozzle, and it is necessary to avoid the mixing of sundries.
6. When using a pressure relief hand pump, after the pressure reaches the rated value, return the joystick to the locked position to release the system pressure.

### Specification

Model	Discharge	Pressure	Lubricant	Capacity	Pressure relief	Weight
EGH	1.0mL/cycle	10MPa	NLGI 000# ~1#	0.3, 0.4, 0.8L	Manual lever	1.4kg

## EGH Dimension

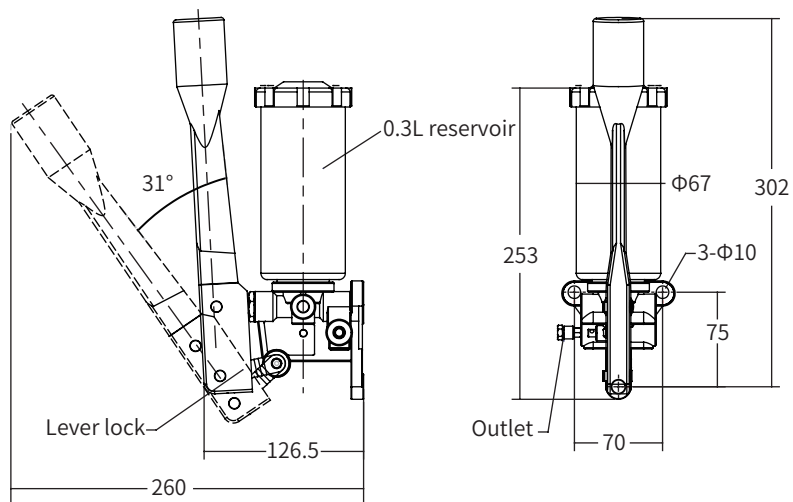

300mL reservoir

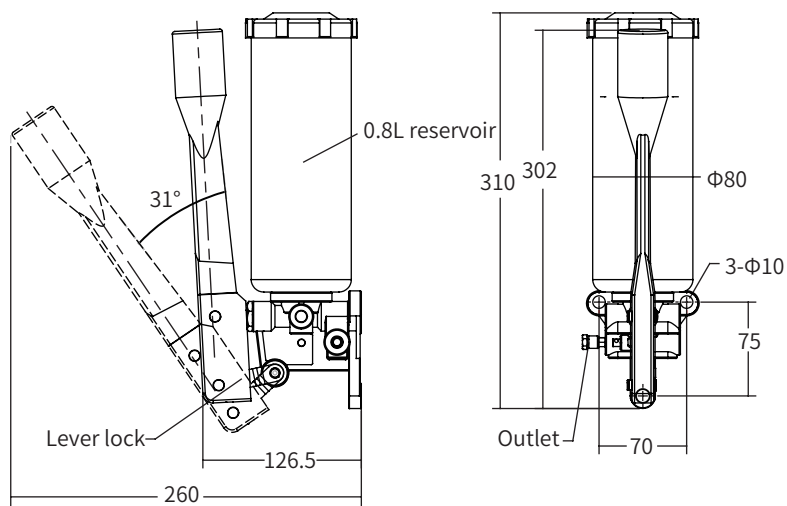

800mL reservoir

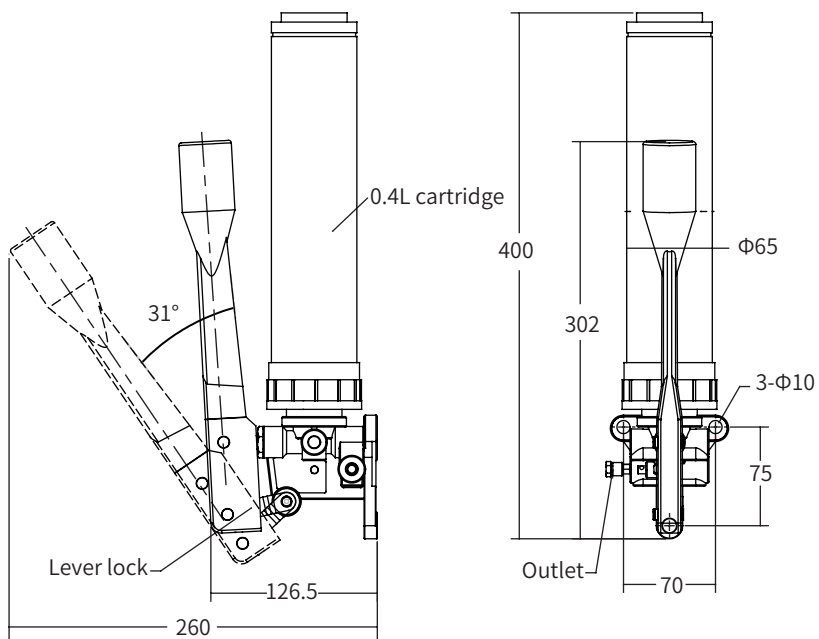

400mL cartridge



## EGHT Progressive Grease Pump

Order code **EGHT-8P-R-6**



EGHT	Progressive type	EGHT-8P-R-6	6	Outlet $\Phi$ 6
4C	0.4L cartridge		8	Outlet $\Phi$ 8
3P	0.3L reservoir		L	Left outlet
8P	0.8L reservoir		R	Right outlet
6HP	0.6L spring (NLGI2)		T	Double outlet



### Feature

1. After the lubricant in the cartridge is used up, it cannot be refilled. Please use the recommended lubricant.
2. Do not use lubricants containing molybdenum disulfide.
3. When using lithium-based grease, please contact us when non-lithium grease must be used.
4. Do not use any lubricant that corrodes brass or rubber.
5. When filling grease, be sure to inject it from the filler nozzle to avoid sundries mixed into the grease.

### Specification

Model	Discharge	Pressure	Lubricant	Capacity	NLGI 2#	Weight
EGHT	1.0mL/cycle	15MPa	NLGI 000# ~1#	0.3, 0.4, 0.8L	0.6L with spring	1.4kg

## EGHT Dimension

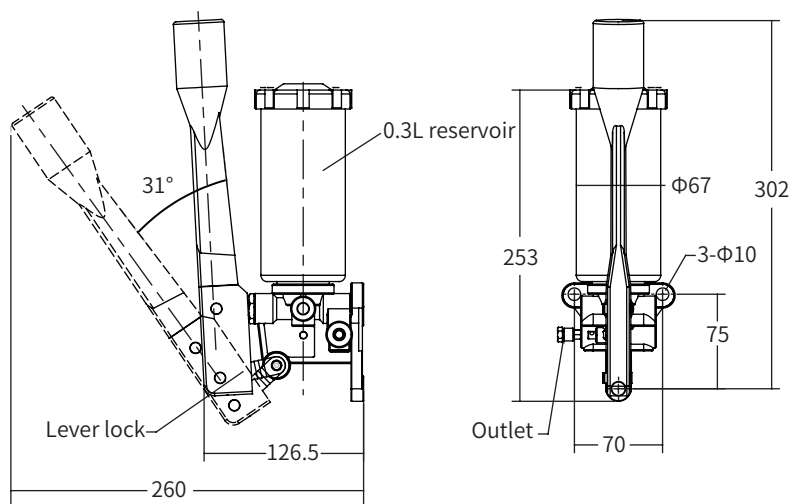

300mL reservoir

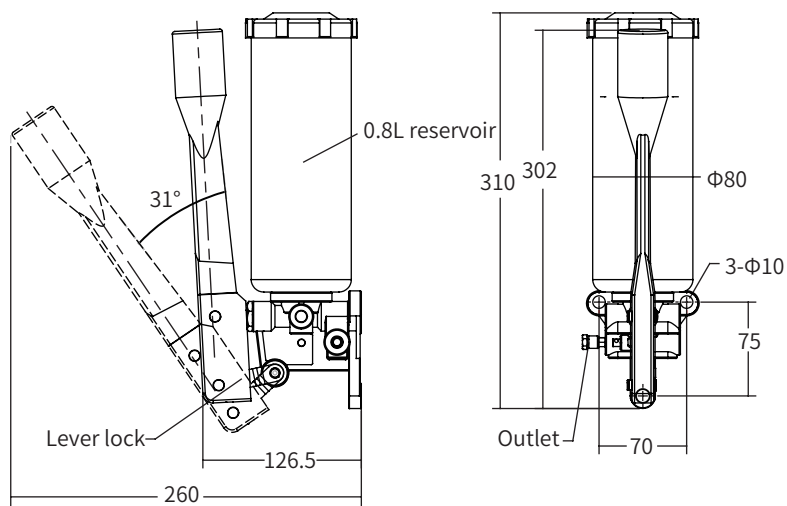

800mL reservoir

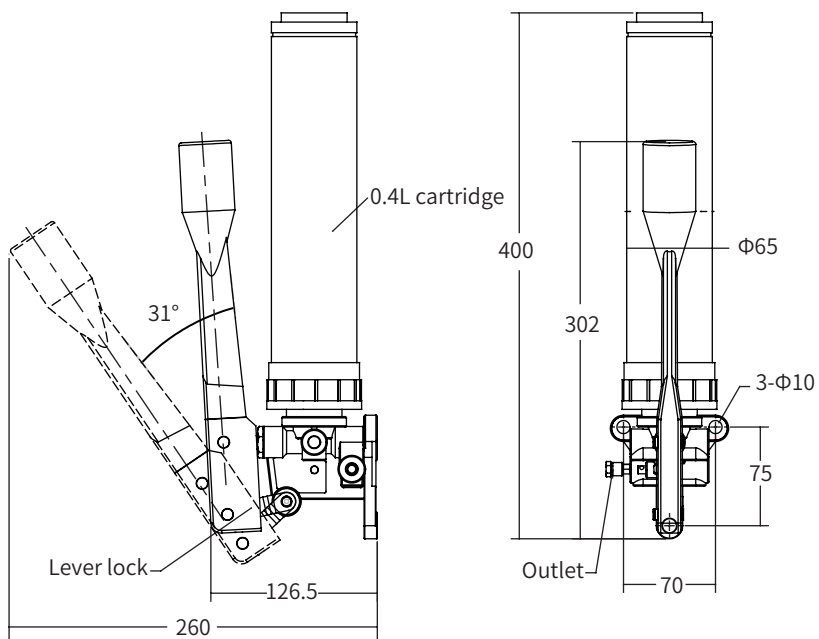

400mL cartridge

## AOM Pneumatic Oil-mist Pump

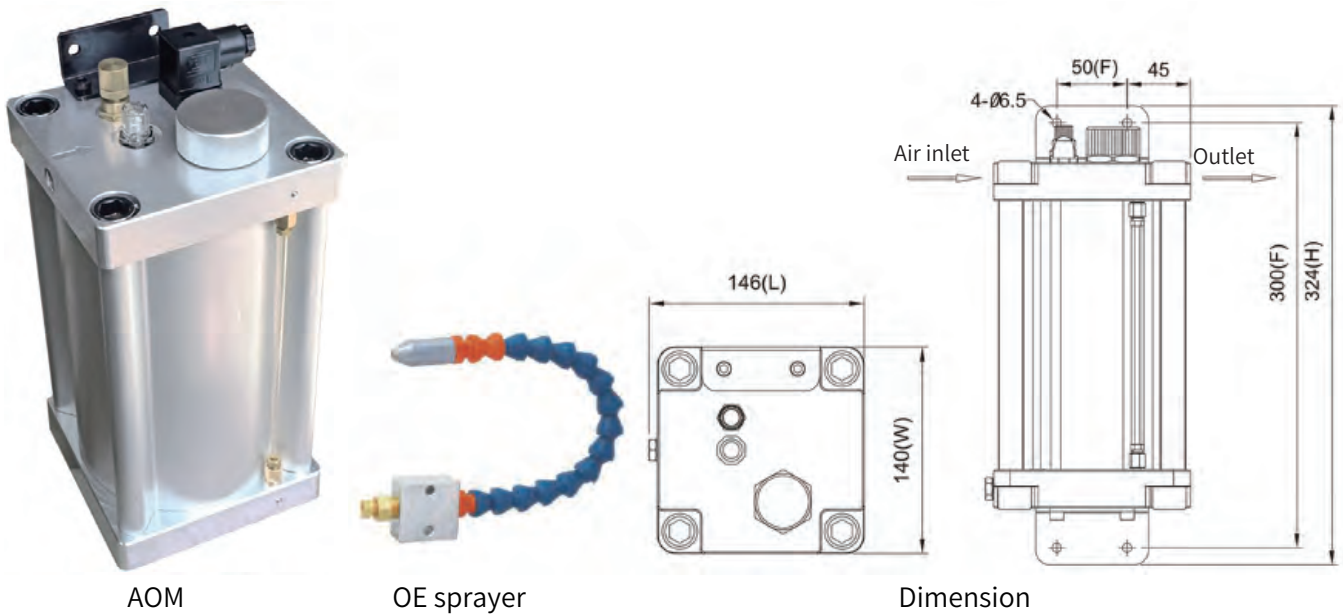

AOM

OE sprayer

Dimension

## Specification

Model	Capacity	Air inlet	Outlet	Pressure	Temperature	Mounting holes	Length(L)	Width(W)	Hight(H)	N.W
AOM	2L	PT/4	PT/4	Max. 15bar	5~60°C	300mm	146mm	140mm	324mm	6kg

## Feature

1. It is suitable for high-speed cutting lubrication, large-area lubrication, special processing lubrication and cooling.
2. The outlet of the pump can be equipped with various types of nozzles, suitable for a variety of cutting tools.
3. It is equipped with an oil volume adjustment knob, which can adjust the oil volume. Rotate the oil volume adjustment knob counterclockwise, the larger the air volume, the more oil mist volume. Clockwise rotation, the less oil mist.
4. The oil drop transparent window can observe whether the pump is normal, and the oil mirror can observe oil level.
5. The air pressure source of the pump can be directly driven with the air compressor, or the solenoid valve can be used to control the ON/OFF switching action of the air source.
6. The range of air pressure source is 4~8bar, and the atomization effect is the best.
7. Please use lubricating oil or cutting water with a viscosity range of 22-68cst@40°C, but it is forbidden to add volatile oil, such as ester, ethylene glycol-based oil.

## Order code

**A O M - 2 - F**

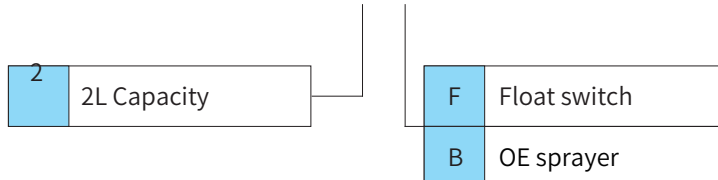

## PHA/PHB Pneumatic Oil Pump



PHA-4



PHA-2

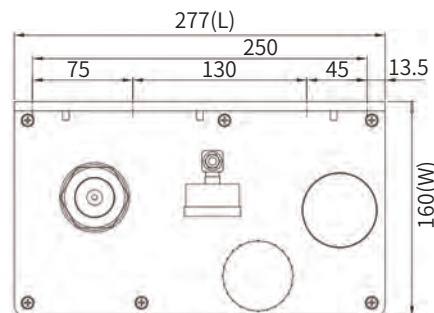

160(W)

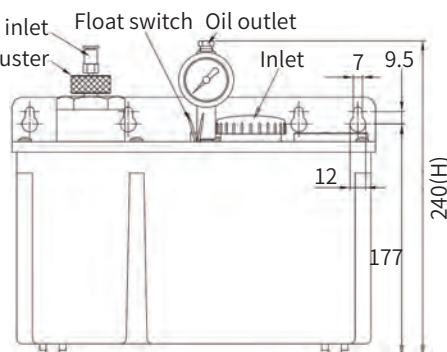

### Order code PH - A - 2 - 3 - 0

A	Resistance
B	Pressure relief
2	2L reservoir
3	3L eservoir
4	4L eservoir

0	Air hose $\Phi 4$
1	Air hose $\Phi 6$
0	Outlet $\Phi 4$
1	Outlet $\Phi 6$
2	Outlet $\Phi 4$ (gauge)
3	Outlet $\Phi 6$ (gauge)

## Feature

1. The pneumatic lubricating pump is driven by air pressure controlled by a solenoid valve, and the pressure is controllable, providing intermittent oil supply.
2. PHA is a resistance type, with a displacement of 0~8mL/cycle, which can be adjusted. Rotate the control valve clockwise to increase the discharge, and rotate counterclockwise to reduce the discharge.
3. PHB is a pressure relief type and needs to be used with volumetric distributors, such as DPB, LT and MO distributors.
4. The specification of the attached float switch is the energized contact under the liquid level, and the upper energized contact can also be selected.
5. The pressure gauge device can be selected according to customer needs.
6. The oil outlet can be equipped with a pressure switch.
7. The flow rate of PHA/PHB is small, which is suitable for mechanical equipment with small flow rate.

## Specification

Model	Code	Reservoir	Capacity(L)	Fixed hole(mm)	Length L(mm)	Wide W(mm)	High H(mm)	N.W(kg)
PHA/PHB	2	Resin	2	144	168	117.5	226	1.88
	3		3	170	204	161.5	221	2.50
	4		4	250	277	160.5	240	3.40

## ASK Pneumatic Grease Pump



### Ordercode

ASK-2-2-B-N-6-6

2	Resistance type	6	Outlet dia. 6mm
4	Pressure-relief	8	Outlet dia. 8mm
2	2L reservoir	6	Air hose 6mm
A	Solenoid valve 110V	8	Air hose 8mm
B	Solenoid valve 220V	N	No level switch
D	Solenoid valve 24V	O	Level switch NO

### Dimension

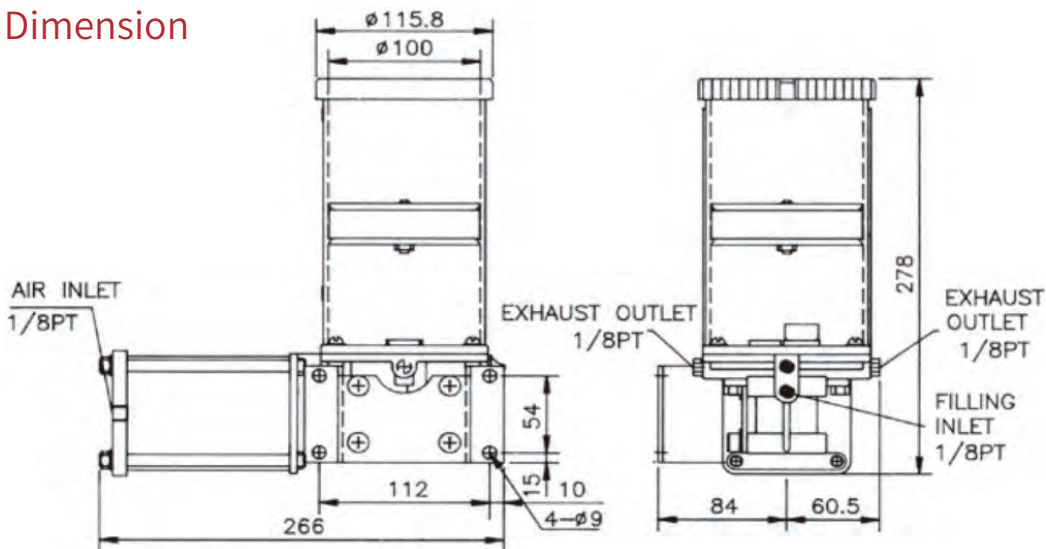

1. The pressure output is adjustable to meet the needs of various machines.
2. The touch switch can make the machine get the right amount of lubrication.
3. Optional timing control device to control lubrication time and interval time.
4. Optional oil pressure detection device can detect leakage.
  - ① Pipeline rupture: It is detected that the pressure in the pipe is insufficient.
  - ② Insufficient wind pressure: It is detected that the wind pressure is insufficient.
  - ③ Insufficient oil pressure: The detected parts are damaged and the output power is poor.
5. There is a bee island device, and an alarm sound is issued when abnormal.

### Specification

Model	Controller	Output	Solenoid valve	Air pressure	Floating ball	Capacity	Output pressure	Viscosity
ASK-2	Optional	15	24V, 110V, 220V	5~7bar	Optional	2L	Max 40~50bar	below NLGI 0#
ASK-4								

## GS Self-priming Cooling Lubrication Sprayer

### Feature

This sprayer is powered by the air source of the air compressor and the principle of vacuum self-priming, which mixes and atomizes the liquid and air, and then sprays it to the lubrication point of the workpiece, tool or bearing. It has good cooling effect, and provides functions such as lubrication, chip removal, cleaning, etc., which improves production efficiency and processing quality, and reduces tool wear and workshop pollution.

1. Cooling, lubricating and blowing off iron filings can be done at one time during processing.
2. It can improve the processing cutting speed, save processing time and reduce tool wear.
3. It can ensure the precision of the workpiece and the best use of the tool.
4. Processing alloy or superhard material can also achieve smooth and high precision.
5. The new sealing pipeline can avoid oil leakage and prolong the service life.
6. The air volume and coolant on the sprayer can be adjusted to adapt to different processing conditions.
7. There are different fixed tubes to choose from, which is convenient for fixed installation.

### Precautions

1. Clean liquid must be used.
2. Do not use corrosive liquids.
3. The air source pressure range is 5-7kgf/cm<sup>2</sup>.
4. The viscosity of the liquid used is below 68cSt.
5. It can be used in sawing machines, lathes, grinders, tapping machines, CNC machining centers, punching machines and other cutting and processing equipment.



### Dimension

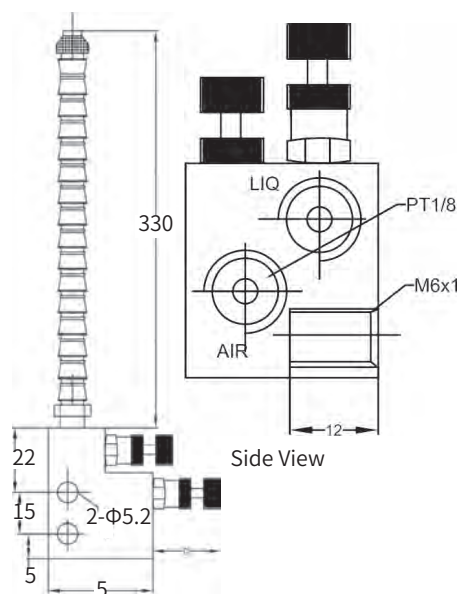

### Order code

**GS-300-4-8-A-1-1-F**

300	300mm length	D	Liquid tube connector
4	Liquid tube Φ4	F	Quick connector
6	Liquid tube Φ6	1	Air tube connector
6	Air tube Φ6	2	Quick connector
8	Air tube Φ8	1	With check valve
A	Large atomization /adjustable	2	No check valve
S	Micro-atomization/nonadjustable		



## ADY-50S Large Pump Head High Pressure Grease Injector

### Feature

The inlet is equipped with a filter screen, a super wear-resistant polyurethane grease seal is used. The pump is designed for high-viscosity grease, air inlet is equipped with a double-cup oil-water separator. The pump is not suitable for corrosive grease, suitable for grease NLGI #00 to #3 and high temperature special grease.



### Specification

Pressure ratio	80: 1
Maximum pressure	80MPa
Maximum discharge	600-900g/min
Maximum viscosity	NLGI #00 to #3
Pressure range	0.5-0.9MPa
Temperature	80°C
Pump head	80m
Tubing length	10m or 15m
Refill method	Replace 15-20kg bucket
Product weight	20kg
Package size	800*400*400mm

## High Pressure Grease Tube Reel



Open-type reel



Closed-type reel

Specifications	Open-type	Closed-type
Tubing size	8mm*6mm	8mm*6mm
Max. discharge	5L/min	5L/min
Max. pressure	28MPa	280MPa
Connection	M14*1.0	M14*1.0
Tubing length	10m, 15m	15m
Product weight	15kg(10m), 20kg(15m)	18kg
Package size	400*350*220mm(10m), 450*400*260mm(15m)	410*400*250mm



## ADY-50S Large Pump Head High Pressure Grease Injector

### Dimension



Stress 80:1



## ADY-50S Large Pump Head High Pressure Grease Injector

### Dimension

If you want to adjust the parts on the reel, the ones in the red box, you need to remove all the screws in the red circle, then you can adjust the orientation of the parts.

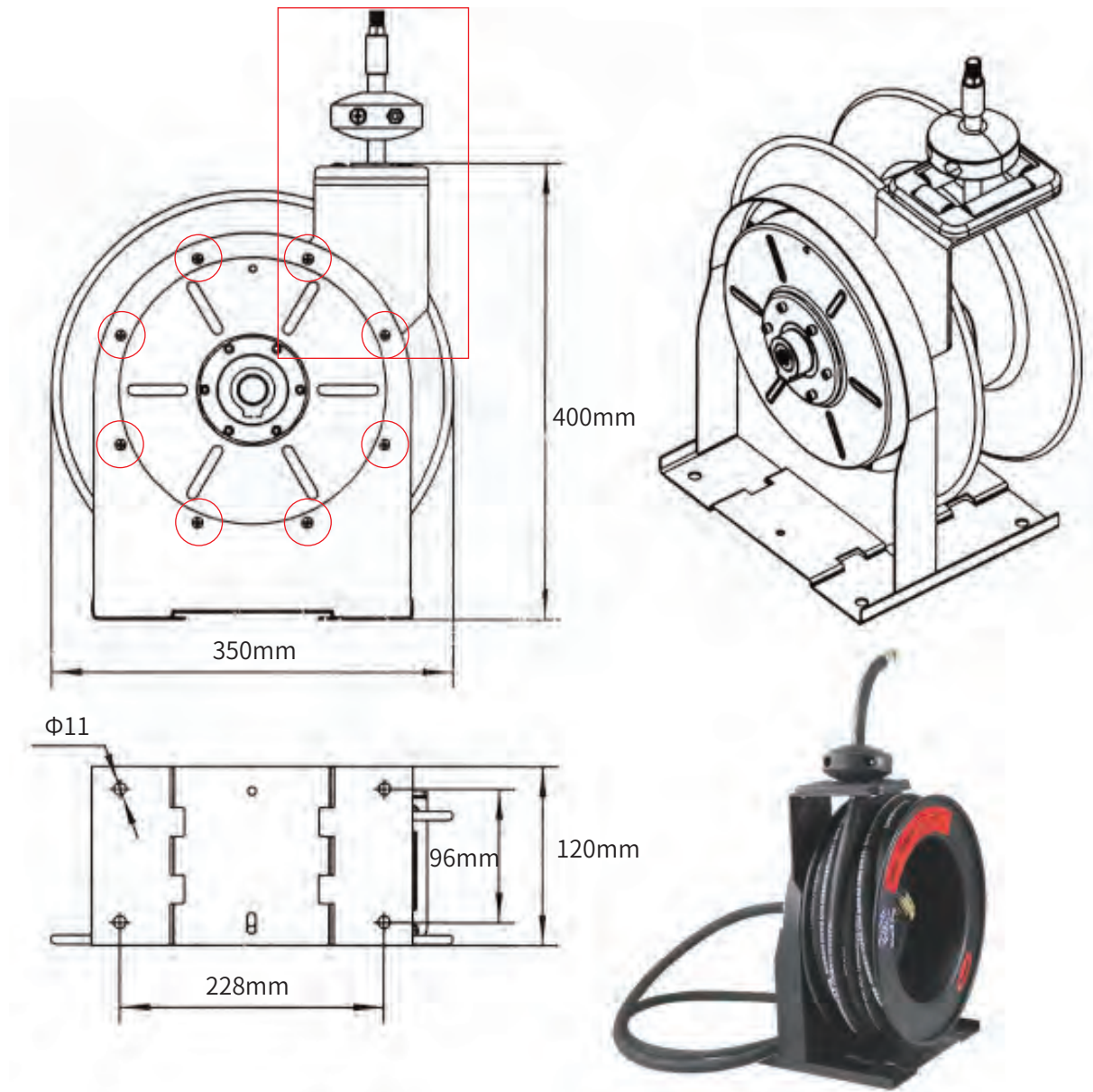

### Specification

Model	Hose length	Internal dia.	Hose materia	Hose pressure	Reel inlet	Hose outlet
R35015	15m	6mm	S.A.E. 100R1AT	28MPa	M14*1	M14*1

## Proportional Connector

A filter screen, a restrictor rod and a one-way valve inside, the flow is proportionally distributed through the throttling principle. Long service life, sensitive action and smooth oil discharge. For use in resistance oil lubrication systems.

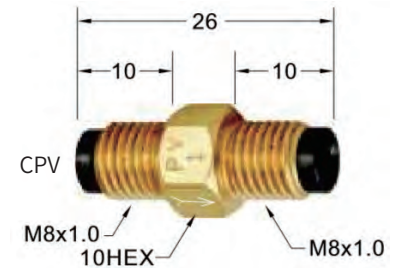
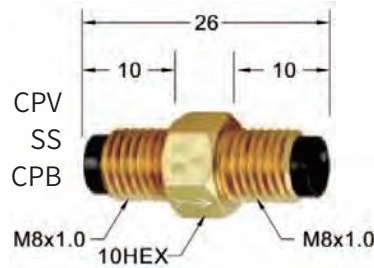
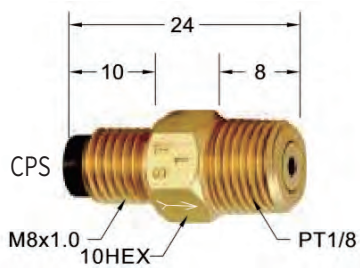

Specification	Model	Code					Ext. thread	N.W(g)	Code				
For NLGI 000~0#	CPS	1	2	3	4	5	M8xPT1/8	10	1	2	3	4	5
	CPB						M8xM8	9					
One-way check valve	CPT	1	2	3	4	5	M8xPT1/8	10	Flow Rate				
	CPV(standard)						M8x1.0	9	1	2	3	4	5
	CPV(nipple)						M8x1.0	9					

Specification	Model	Code					Ext. thread	N.W(g)	Code						
One-way large flow	ST	0	1	2	3	4	5	M8xPT1/8	9	0	1	2	3	4	5
	SS							M8x1.0	8	Flow Rate					
									2	4	8	16	32	64	

## Type-B Adjustable Distributor



Model	Outlets	Inlet	Outlet	A(mm)	B(mm)	N.W(Φ4)	N.W(Φ6)
B-2	2	Φ6/Φ4	Φ4/Φ6	47	37	96	99
B-3	3			62	52	127	130
B-4	4			77	67	159	162
B-5	5			92	82	189	192
B-6	6			107	97	221	224
B-7	7			122	112	251	254
B-8	8			137	127	283	286
B-9	9			152	142	323	316
B-10	10			167	157	343	346
B-12	12			197	187	404	407

## Order code

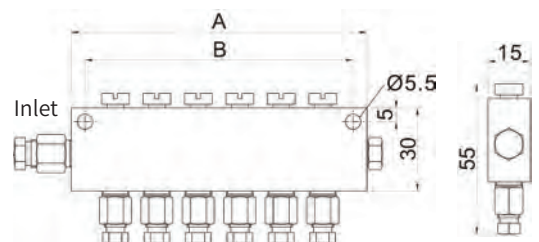
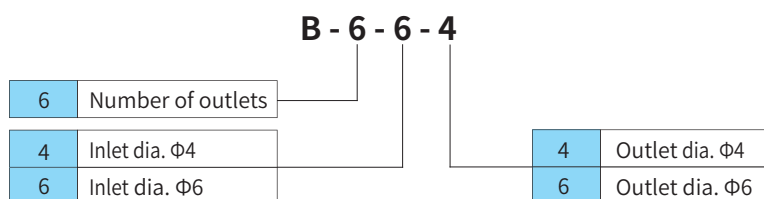

## Type-A distributor

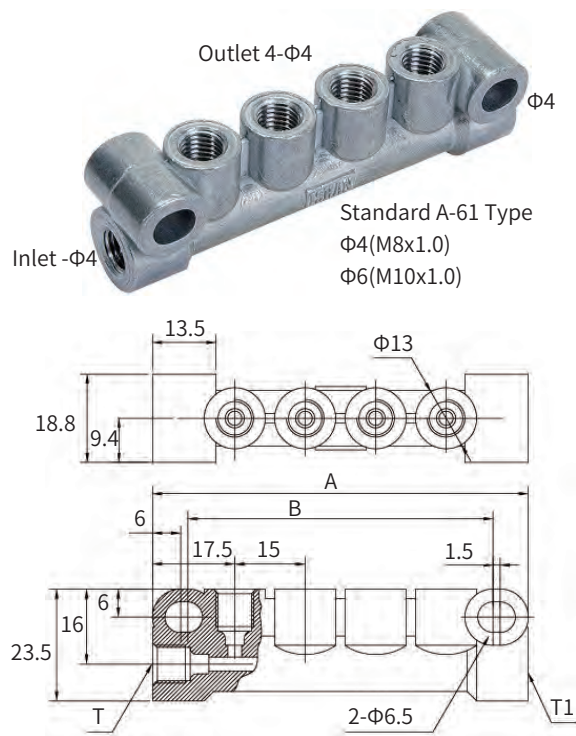

Model	T/T1	Outlet dia.	Inlets+outlets	A	B	N.W(g)
A41	Φ4	2-Φ4				
A42	Φ6	2-Φ4	4	48	34-36	59
A43	Φ6	2-Φ6				
A51	Φ4	3-Φ4				
A52	Φ6	3-Φ4	5	64	49-52	76
A53	Φ6	3-Φ6				
A61	Φ4	4-Φ4				
A62	Φ6	4-Φ4	6	80	60-68	96
A63	Φ6	4-Φ6				
A71	Φ4	5-Φ4				
A72	Φ6	5-Φ4	7	96	79-84	113
A73	Φ6	5-Φ6				
A81	Φ4	6-Φ4				
A82	Φ6	6-Φ4	8	112	95-10	135
A83	Φ6	6-Φ6				
A91	Φ4	7-Φ4				
A92	Φ6	7-Φ4	9	128	109-116	145
A93	Φ6	7-Φ6				
A101	Φ4	8-Φ4				
A102	Φ6	8-Φ4	10	144	123-132	164
A103	Φ6	8-Φ6				
A121	Φ4	10-Φ4				
A122	Φ6	10-Φ4	12	176	153-164	201
A123	Φ6	10-Φ6				

## AE Distributor

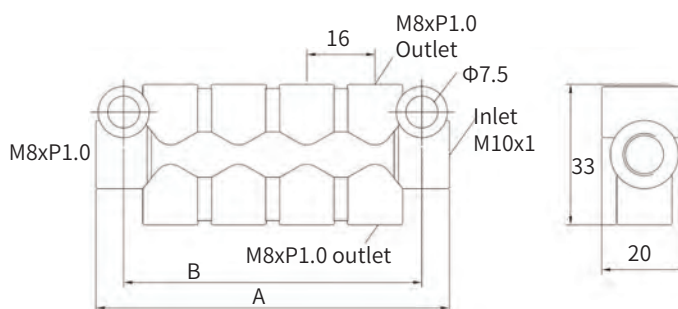

## Specification

Model	Outlets	A(mm)	B(mm)	N.W(Φ4)	N.W(Φ6)	Outlet dia.	Inlet dia.
AE-4	4	48	35	73g	71g	Φ4	Φ6 or Φ4
AE-6	6	65	51	103g	101g		
AE-8	8	83	70	128g	124g		
AE-10	10	97	83	151g	148g		
AE-12	12	112	99	179g	171g		

## Order code

**AE - 8 - 6 - S**

4~12	Number of outlets
4	Inlet diameter Φ4
6	Inlet diameter Φ6

S	Screw-in type fittings
N	No fittings



## LT Pressure-relief Distributor

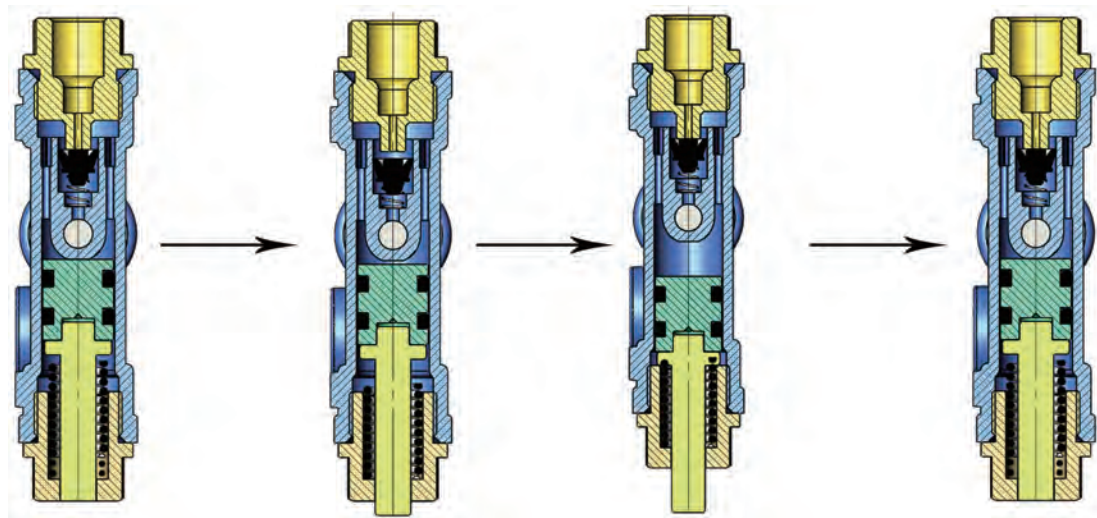

1. Before oil storage (Pressurization starts)      2. During oil storage (In pressurization)      3. After oil storage (After pressurization)      4. During oil discharge (Piston recovery)

1. The pumped oil pushes up the umbrella valve in the distributor.
2. After oil outlet is closed by the umbrella valve, oil pressure causes the piston to overcome spring force to drop, and the oil chamber is used to store oil.
3. When the piston is pushed to the top of the oil chamber, oil storage is completed.
4. When the pump stops supplying oil, the pressure relief valve starts, the system pressure drops, the umbrella valve returns and closes the oil inlet, the piston presses oil out of the oil chamber under the action of the spring force.

## Specification

Model	Outlets	A(mm)	B(mm)	C(mm)	Weight	Inlet	Outlet	Output	Pressure
LT-2	2	40	55	15	167g	M10x1 Φ6	M8x1 Φ4	0.1mL	8bar to 30bar
LT-3	3	55	70	30	232g			0.2mL	
LT-4	4	70	85	45	297g			0.3mL	
LT-5	5	85	100	60	362g			0.4mL	
LT-6	6	100	115	75	427g			0.5mL	
LT-7	7	115	130	90	492g			0.06mL	



## Order Code

<b>LT</b>	<b>2</b>	<b>2</b>	<b>5</b>
<b>Outlets</b>	<b>1st output</b>	<b>2nd output</b>	
2 = 2 oil outlets	1 = 0.1mL/cyc	1 = 0.1mL/cyc	
3 = 3 oil outlets	2 = 0.2mL/cyc	2 = 0.2mL/cyc	
4 = 4 oil outlets	3 = 0.3mL/cyc	3 = 0.3mL/cyc	
5 = 5 oil outlets	4 = 0.4mL/cyc	4 = 0.4mL/cyc	
6 = 6 oil outlets	5 = 0.5mL/cyc	5 = 0.5mL/cyc	
7 = 7 oil outlets	06 = 0.06mL/cyc	06 = 0.06mL/cyc	

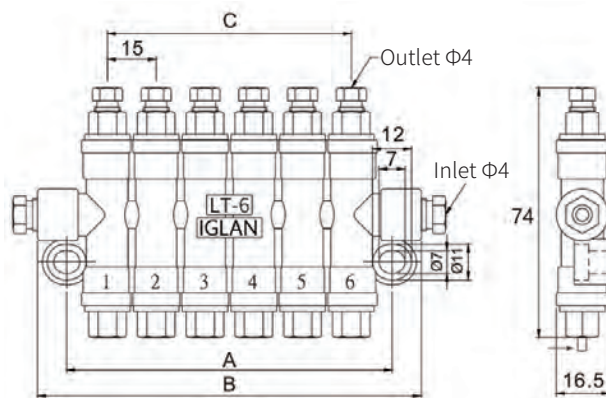

## DPB1 Pressurized Distributor

### Feature

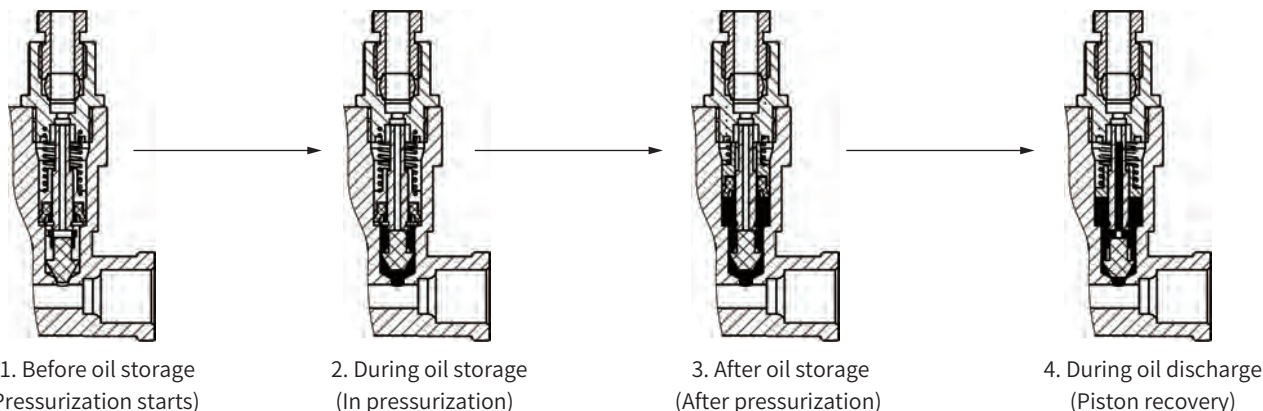

1. The pumped oil pushes up the umbrella valve in the distributor.
2. After the umbrella valve closes the center hole of core rod, oil pressure forces the piston to rise against the spring force and discharge oil originally stored in upper chamber.
3. When the piston moves to the top of the oil chamber, the oil discharge is completed.
4. When the pump stops supplying oil, the pressure relief valve is activated, the system pressure drops, and the piston returns under the spring force. When the umbrella valve closes the oil inlet, piston presses the oil in the lower chamber to the upper chamber through the small hole of the core rod, and oil storage for next cycle is completed.

### Specification

Model	Outlets	A(mm)	B(mm)	Weight	Inlet	Outlet	Output	Pressure
DPB11	1	-	40	55g	M10x1 Φ6	M8x1 Φ4	0.03mL 0.06mL 0.10mL 0.16mL	8bar to 30bar
DPB12	2	-	48	100g				
DPB13	3	17	65	145g				
DPB14	4	34	82	190g				
DPB15	5	51	99	236g				
DPB16	6	68	116	281g				
DPB18	8	102	150	371g				
DPB110	10	136	184	461g				

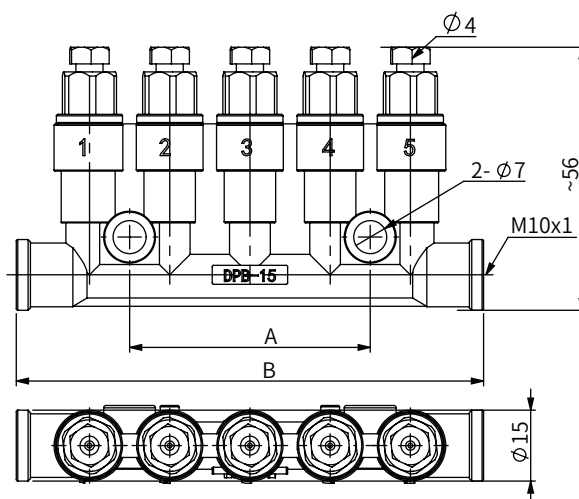

### Order Code

<b>DPB1</b>	<b>2</b>	<b>3</b>	<b>6</b>
<b>Outlets</b>	<b>1st output</b>	<b>2nd output</b>	
2 = 2 oil outlets	3 = 0.1mL/cyc	3 = 0.1mL/cyc	
3 = 3 oil outlets	6 = 0.2mL/cyc	6 = 0.2mL/cyc	
.....	10 = 0.3mL/cyc	10 = 0.3mL/cyc	
10 = 10 oil outlets	16 = 0.16mL/cyc	16 = 0.16mL/cyc	



## DPB2 Pressurized Distributor

### Specification

Model	Outlets	A(mm)	B(mm)	Inlet	Outlet	Output	Pressure
DPB21	1	-	40	M12x1 Φ6	M8x1 Φ4	0.1mL	8bar
DPB22	2	-	46				
DPB23	3	14	63				
DPB25	5	51	97				
DPB26	6	68	114				
DPB28	8	102	148				
DPB210	10	136	182				

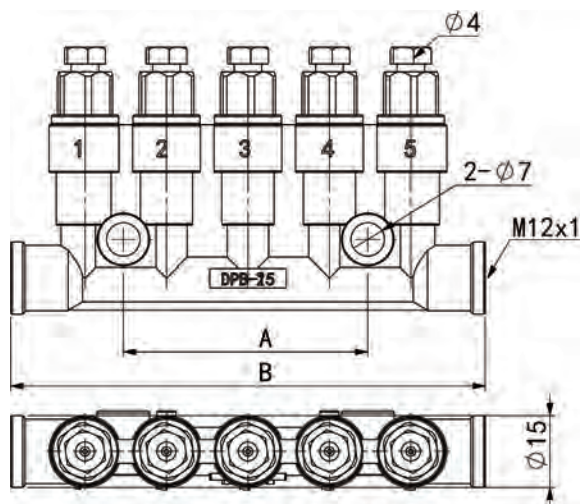

### Order Code

<b>DPB2</b>	<b>2</b>	<b>3</b>	<b>6</b>
	<b>Outlets</b>	<b>1st output</b>	<b>2nd output</b>
	2 = 2 oil outlets	1 = 0.1mL/cyc	1 = 0.1mL/cyc
	3 = 3 oil outlets	2 = 0.2mL/cyc	2 = 0.2mL/cyc
	.....	3 = 0.3mL/cyc	3 = 0.3mL/cyc
	10 = 10 oil outlets	4 = 0.4mL/cyc	4 = 0.4mL/cyc





## MO Metering Valve Unit

## Specification



Model	Metering volume	Mark	L(mm)	Fittings	Pressure	Recovery
MO-3	0.03mL/cyc	3	48	Screw-in	≥1.0MPa	≤0.3MPa
MO-5	0.05mL/cyc	5	48			
MO-10	0.10mL/cyc	10	48			
MO-20	0.20mL/cyc	20	64			
MO-30	0.30mL/cyc	30	64			
MO-50	0.50mL/cyc	50	64			
MOC-3	0.03mL/cyc	3	53.5	Push-in		
MOC-5	0.05mL/cyc	5	53.5			
MOC-10	0.10mL/cyc	10	53.5			
MOC-20	0.20mL/cyc	20	69.5			
MOC-30	0.30mL/cyc	30	69.5			
MOC-50	0.50mL/cyc	50	69.5			

## Order code

<b>MO</b>	<b>5</b>
<b>Fittings</b>	<b>Metering volume</b>
MO = Screw-in Type	3 = 0.03mL/cyc
MOC = Push-in Type	5 = 0.05mL/cyc
	10 = 0.10mL/cyc
	20 = 0.20mL/cyc
	30 = 0.30mL/cyc
	50 = 0.50mL/cyc

## Dimension

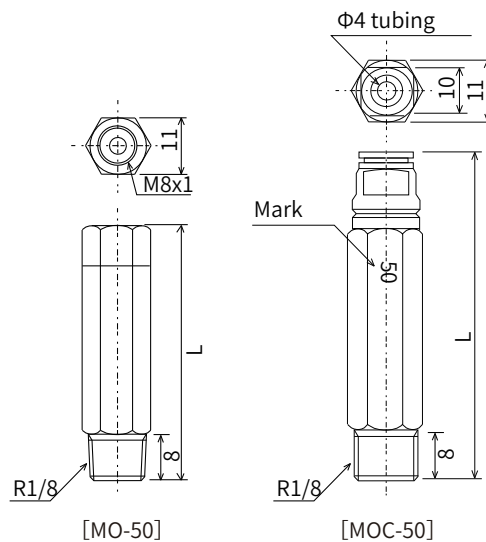

## Feature

1. The pressurized metering method is a direct pressure action type distributor. The pressure oil output from the pump pushes the piston built in the metering valve to discharge the lubricant. When the pump stops working, the internal piston recovers under the action of the spring force to store the lubricant.
2. The oil discharge is accurate, and only one discharge in one metering cycle. Whether the distributor is far, near, high or low in the lubrication system, horizontal or vertical installation has no effect on the discharge of the metering valve.
3. Forced oil discharge, sensitive action, two seals to prevent backflow of discharge.
4. The metering valve and the connecting block are independent. According to the lubrication amount of each lubrication point, choose the combination of metering valve and MOJ connection block, which can be used in series or in parallel.
5. The outlet fittings of the metering valve is Φ4, and there are two connection methods.  
Screw-in type: composed of PA4 and PB4.  
Push-in type: insert the Φ4 tube directly.

## Connection Block (Φ6, Φ8 tubing)

### Order Code

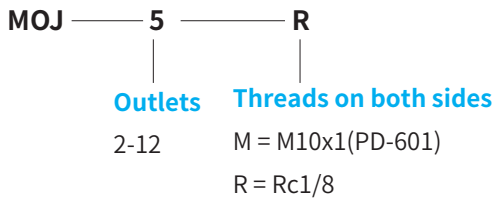

MOJ+MO

### Feature

1. The connecting block diverts lubricant in one direction.
2. It is used in thin oil single-line lubrication system.  
The MO metering valve is directly connected to it and delivers lubricant to the lubrication point. If there are redundant outlets, M10\*1 closure plugs can be used to close them.  
The Φ6 main line is connected with MOJ-M, and its outlet thread is M10x1, which is used in combination with PA-6 connector and PB-6 double cone ferrule. Its end port can be closed with PG06 closure plug.  
Φ6 main line is connected with MOJ-R. Its outlet thread is Rc1/8, which can be used with straight connector. Its end port can be closed with Rc1/8 closure plug.
3. Made of aluminum alloy, the surface is anodized, and the appearance is beautiful.
4. Special requirements can be customized
5. According to the actual needs of the lubrication system, the connection blocks can be used in parallel or in series.

### Specification

Model	Outlets	L1	L2
MOJ-1R	1	31	20
MOJ-2R	2	47	36
MOJ-3R	3	65	54
MOJ-4R	4	81	70
MOJ-5R	5	97	86
MOJ-6R	6	113	102
MOJ-7R	7	129	118
MOJ-8R	8	145	134
MOJ-9R	9	161	150
MOJ-10R	10	177	166
MOJ-12R	12	209	198

### Dimension

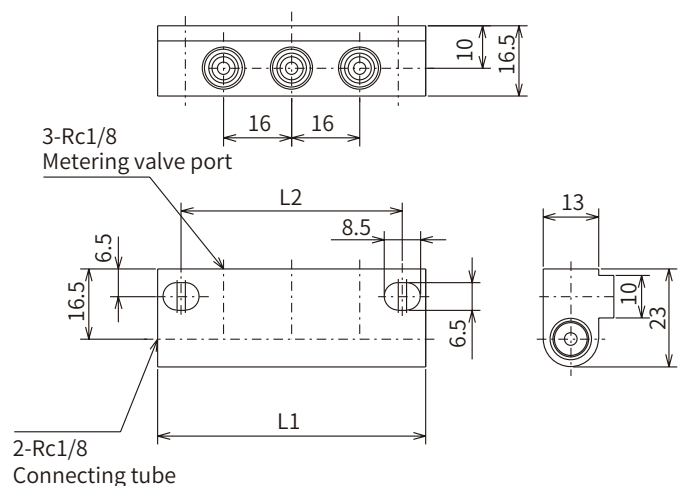

[Connection Block MOJ-3S]

## AO Pressurized Oil-air Distributor

### Feature

AO type distributor is a metering oil and air lubrication distributor developed with advanced oil and air mixer technology.

There are four kinds of measuring volumes: 0.03, 0.06, 0.1, 0.16mL/cycle.

Any combination of different discharges is superimposed, and the number of distributor outlets is 1 to 6.

The AO distributor can adjust and control the air flow through the air flow adjustment screw.

A small amount is discharged, and the utilization rate of lubricant is high.

Oil viscosity range: 10-750cSt.

### Specification

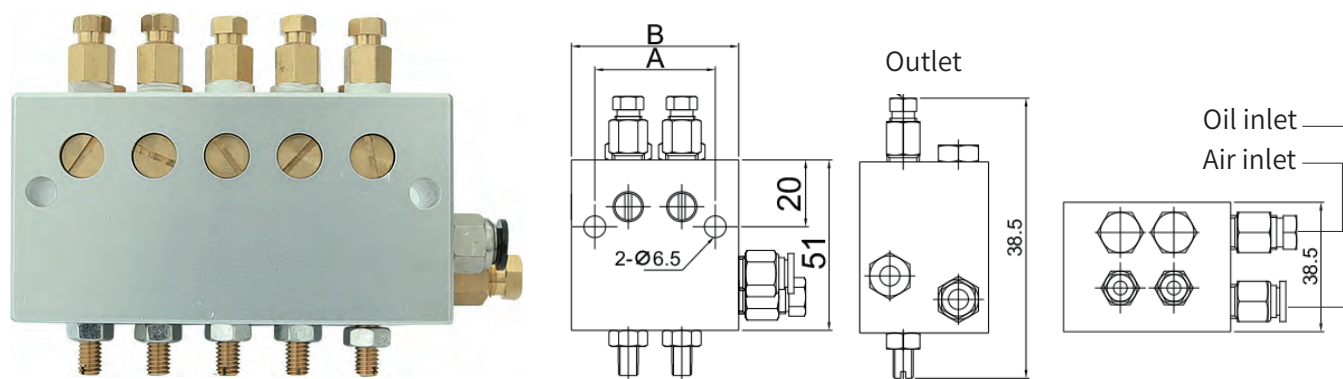

Model	Outlets	A(mm)	B(mm)	Metering volume	Oil inlet	Oil outlet	Oil pressure	Air pressure	Function
AO-1	1	20	4	0.03mL/cycle 0.06mL/cycle 0.10mL/cycle 0.16mL/cycle	M10xP1.0 Φ6	M8xP1.0 Φ4	15~30bar	4~7bar	Air volume regulation
AO-2	2	36	50						
AO-3	3	52	66						
AO-4	4	68	82						
AO-5	5	84	98						
AO-6	6	100	114						

### Order code

<b>AO</b>	<b>6</b>	<b>1</b>	<b>2</b>	<b>3</b>	<b>4</b>	<b>5</b>
	<b>Outlets</b>	<b>1st output</b>	<b>2nd output</b>	<b>3rd output</b>	<b>4th output</b>	<b>5th output</b>
	1 = 1 oil outlets	1 = 0.03mL/cyc	1 = 0.03mL/cyc	1 = 0.03mL/cyc	1 = 0.03mL/cyc	1 = 0.03mL/cyc
	2 = 2 oil outlets	2 = 0.06mL/cyc	2 = 0.06mL/cyc	2 = 0.06mL/cyc	2 = 0.06mL/cyc	2 = 0.06mL/cyc
	3 = 3 oil outlets	3 = 0.10mL/cyc	3 = 0.10mL/cyc	3 = 0.10mL/cyc	3 = 0.10mL/cyc	3 = 0.10mL/cyc
	4 = 4 oil outlets	4 = 0.16mL/cyc	4 = 0.16mL/cyc	4 = 0.16mL/cyc	4 = 0.16mL/cyc	4 = 0.16mL/cyc
	5 = 5 oil outlets					
	6 = 6 oil outlets					

## MU Metering Valve Unit

## Specification



Model	Metering volume	Mark	L(mm)	Fittings	Pressure	Recovery
MG2-5	0.05mL/cyc	5	37.4	Screw-in	≥1.5MPa	≤0.5MPa
MG2-10	0.10mL/cyc	10	37.4			
MG2-20	0.20mL/cyc	20	50.4			
MG2-30	0.30mL/cyc	30	57.8			
MG2-50	0.50mL/cyc	50	57.8			
MG2C-5	0.05mL/cyc	5	46.7	Push-in		
MG2C-10	0.10mL/cyc	10	46.7			
MG2C-20	0.20mL/cyc	20	59.7			
MG2C-30	0.30mL/cyc	30	66.1			
MG2C-50	0.50mL/cyc	50	67.1			

## Order Code

<b>MU</b>	<b>5</b>
<b>Fittings</b>	<b>Metering volume</b>
MU = Screw-in type	5 = 0.05mL/CY
MUC = Push-in type	10 = 0.10mL/CY
	20 = 0.20mL/CY
	30 = 0.30mL/CY
	50 = 0.50mL/CY

## Dimension

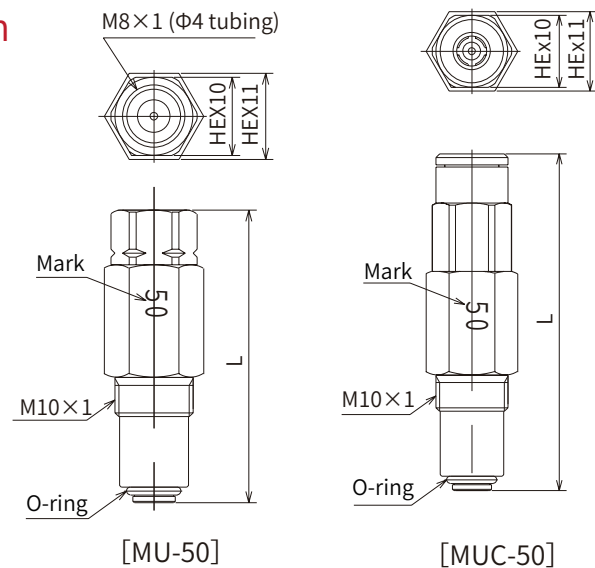

## Feature

- MU is a pressurized direct pressure action metering valve. The pressure lubricant delivered by the pump pushes the piston in the metering valve to forcibly discharge the lubricant. When the pump stops working, the piston recovers under the action of the spring force, and the lubricant is stored.
- The discharge is accurate, and one metering cycle is only discharged once. Whether the distributor is far, near, high or low in the lubrication system, horizontal or vertical installation has no effect on the discharge of the metering valve.
- Forced discharge, sensitive action, there are two seals to prevent backflow of discharge.
- The metering valve and the connection block are independent. Based on lubrication amount of lubrication points, the metering valve can be freely combined with the MU and MUJ connection blocks, and can be used in series or in parallel.
- The outlet fittings of the metering valve are Φ4, with two types.  
Screw-in type: composed of PA4 and PB4.  
Push-in type: insert the Φ4 tube directly.

## Connection Block (Φ6, Φ8 tubing)

### Order Code

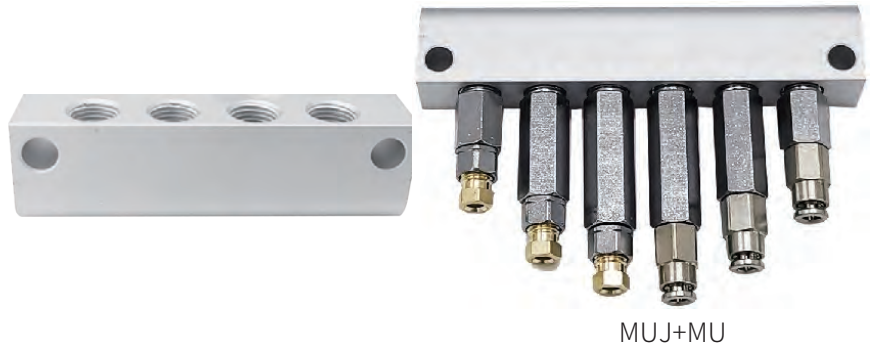
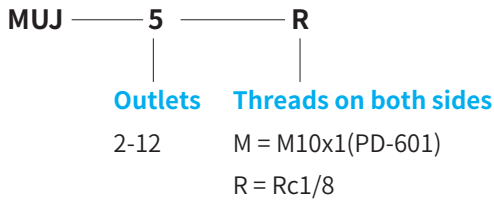

### Feature

1. The connecting block diverts lubricant in one direction.
2. It is used in thin oil single-line lubrication system.

The MO metering valve is directly connected to it and delivers lubricant to the lubrication point. If there are redundant outlets, M10x1 closure plugs can be used to close them.

The Φ6 main line is connected with MOJ-M, and its outlet thread is M10x1, which is used in combination with PA-6 connector and PB-6 double cone ferrule. Its end port can be closed with PG06 closure plug.

Φ6 main line is connected with MOJ-R. Its outlets thread are Rc1/8, which can be used with straight connector. Its end port can be closed with Rc1/8 closure plug.

3. Made of aluminum alloy, the surface is anodized, and the appearance is beautiful.
4. Special requirements can be customized
5. According to the actual needs of the lubrication system, the connection blocks can be used in parallel or in series.

### Feature

Model	Outlets	L1	L2
MUJ-1R	1	31	20
MUJ-2R	2	47	36
MUJ-3R	3	63	52
MUJ-4R	4	79	68
MUJ-5R	5	95	84
MUJ-6R	6	111	100
MUJ-7R	7	127	116
MUJ-8R	8	143	132
MUJ-9R	9	159	148
MUJ-10R	10	175	164
MUJ-12R	12	207	196

### Dimension

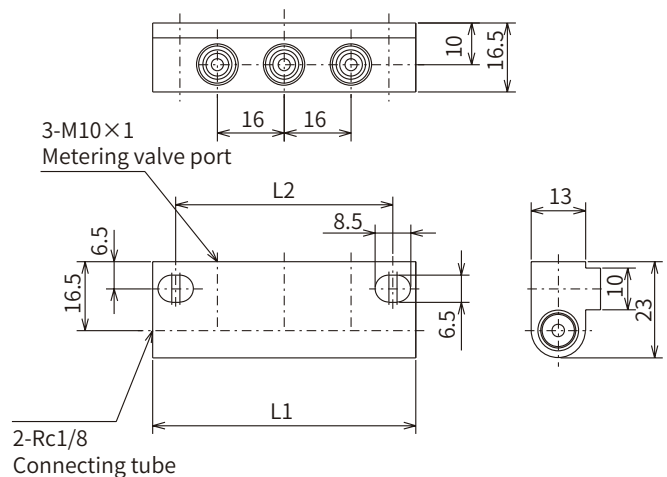

[Connection Block MUJ-3S]

## MG Metering Valve Unit

## Specification



Model	Metering volume	Mark	L(mm)	Fittings	Pressure	Recovery
MG-3	0.03mL/cyc	3	46	Screw-in	≥1.2MPa	≤0.5MPa
MG-5	0.05mL/cyc	5	46			
MG-10	0.10mL/cyc	10	46			
MG-20	0.20mL/cyc	20	53.5			
MG-30	0.30mL/cyc	30	53.5			
MG-50	0.50mL/cyc	50	65			
MGC-3	0.03mL/cyc	3	50.5	Push-in		
MGC-5	0.05mL/cyc	5	50.5			
MGC-10	0.10mL/cyc	10	50.5			
MGC-20	0.20mL/cyc	20	58			
MGC-30	0.30mL/cyc	30	58			
MGC-50	0.50mL/cyc	50	69.5			

## Order code

<b>MG</b>	<b>5</b>
Fittings	Metering volume
MG = Screw-in type	3 = 0.03mL/cyc
MGC = Push-in type	5 = 0.05mL/cyc
	10 = 0.10mL/cyc
	20 = 0.20mL/cyc
	30 = 0.30mL/cyc
	50 = 0.50mL/cyc

## Dimension

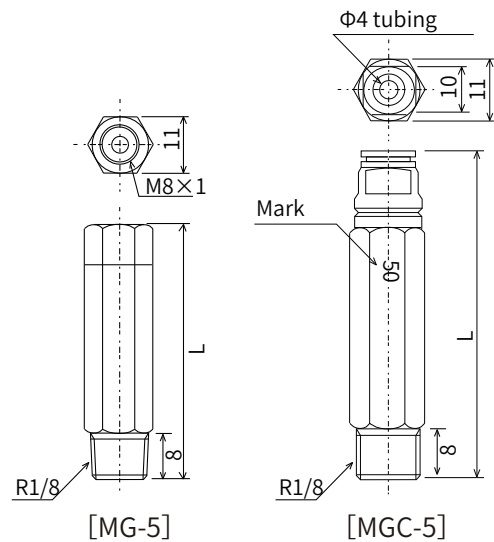

## Feature

1. Pressurized (volumetric) metering valve unit.  
The pressure lubricant discharged by the pump pushes the piston built in the metering valve, forcibly discharging lubricant. When pump stops, the piston is reset by force of spring, and metering valve stores lubricant.
2. The metering volume is accurate. In the lubrication system, far, near, high, low, horizontal or vertical installations have no effect on the metering volume of the metering valve.
3. Forced discharge, sensitive action, two seals are used to prevent backflow of discharge.
4. The metering valve and the junction block are independent. The metering volume can be selected based on the lubrication amount required by each lubrication point. It can be freely combined with the MGJ junction block.
5. The outlet diameter of the metering valve is Φ4, and there are two kinds of outlet connectors.  
Ferrule type: It needs to be used together with PA-4 connector and PB-4 double taper ferrule when connecting tube.  
Quick-plug type: insert the Φ4 nylon tube directly.



## Junction Block ( $\Phi 6$ , $\Phi 8$ tubing)

### Order code

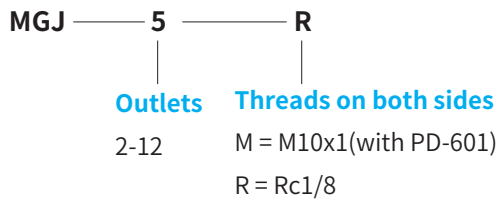

MGJ+MG

### Feature

1. The connector is a one-way shunt.
2. MGJ-M is connected to the main pipeline of  $\Phi 6$ . Its outlet threads are all M10x1, used in combination with PA-6 connector and PB-6 double taper ferrule. The end outlet of the system is closed with a PG06 closure plug.
- MGJ-R is connected to the main pipeline of  $\Phi 6$ . The oil outlet threads are all Rc1/8, which can be directly connected with PD601 straight connector. The outlet at the end of the system is closed with an Rc1/8 closure plug.
3. Made of aluminum alloy, the surface is anodized, and the appearance is beautiful.
4. Mounting holes can also be customized for places where special processing is required.
5. According to the actual lubricating system, choose the connection blocks to be used in parallel or in series.

### Specification

Model	Outlets	L1	L2
MGJ-1R	1	31	20
MGJ-2R	2	47	36
MGJ-3R	3	65	54
MGJ-4R	4	81	70
MGJ-5R	5	97	86
MGJ-6R	6	113	102
MGJ-7R	7	129	118
MGJ-8R	8	145	134
MGJ-9R	9	161	150
MGJ-10R	10	177	166
MGJ-12R	12	209	198

### Dimension

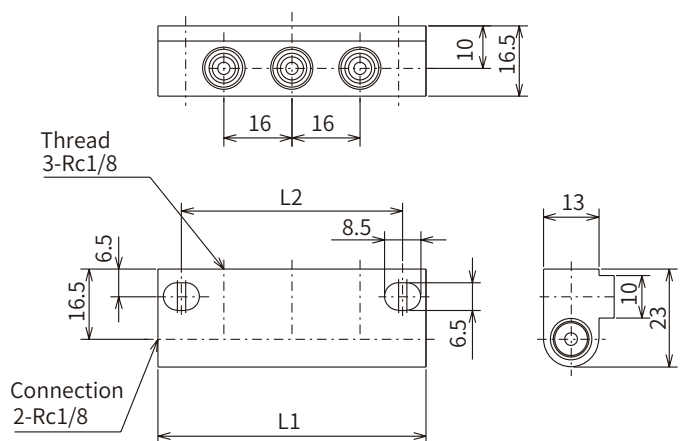

[Junction block MGJ-3R]

## MG2 Metering Valve Unit

## Specification



Model	Metering volume	Mark	L(mm)	Fittings	Pressure	Recovery
MG2-3	0.03mL/cyc	3	48	Screw-in	$\geq 2.5\text{MPa}$	$\leq 1.4\text{MPa}$
MG2-5	0.05mL/cyc	5	48			
MG2-10	0.10mL/cyc	10	48			
MG2-20	0.20mL/cyc	20	64			
MG2-30	0.30mL/cyc	30	64			
MG2-50	0.50mL/cyc	50	64			
MG2C-3	0.03mL/cyc	3	53.5	Push-in		
MG2C-5	0.05mL/cyc	5	53.5			
MG2C-10	0.10mL/cyc	10	53.5			
MG2C-20	0.20mL/cyc	20	69.5			
MG2C-30	0.30mL/cyc	30	69.5			
MG2C-50	0.50mL/cyc	50	69.5			

## Order Code

<b>MG</b>	<b>5</b>
<b>Fittings</b>	<b>Metering volume</b>
MG2 = Screw-in type	5 = 0.05mL/CY
MG2C = Push-in type	10 = 0.10mL/CY
	20 = 0.20mL/CY
	30 = 0.30mL/CY
	50 = 0.50mL/CY

## Dimension

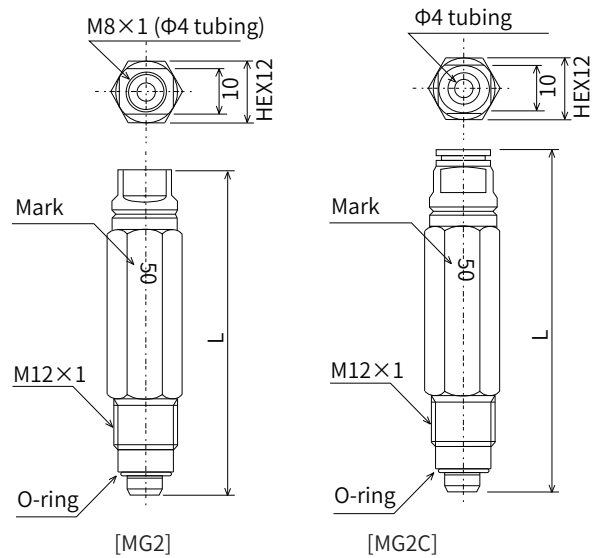

## Feature

1. MG2 is a pressurized direct pressure action metering valve. The pressure lubricant delivered by the pump pushes the piston in the metering valve to forcibly discharge the lubricant. When the pump stops working, the piston recovers under the action of the spring force, and the lubricant is stored.
2. The discharge is accurate, and one metering cycle is only discharged once. Whether the distributor is far, near, high or low in the lubrication system, horizontal or vertical installation has no effect on the discharge of the metering valve.
3. Forced discharge, sensitive action, there are two seals to prevent backflow of discharge.
4. The metering valve and the connection block are independent. Based on lubrication amount of lubrication points, the metering valve can be freely combined with the MG2 and MG2J connection blocks, and can be used in series or in parallel.
5. The outlet fittings of the metering valve are  $\Phi 4$ , with two types.  
Screw-in type: composed of PA4 and PB4.  
Push-in type: insert the  $\Phi 4$  tube directly.

## Connection Block (Φ6, Φ8 tubing)

### Order Code

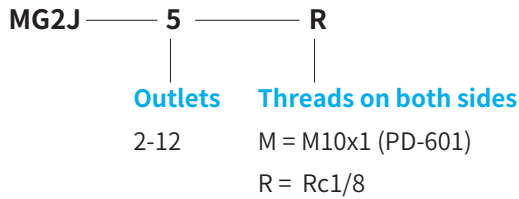

### Feature

1. The connecting block diverts lubricant in one direction.
2. It is used in grease single-line lubrication system.

The MG2 metering valve is directly connected to it and delivers lubricant to the lubrication point. If there are redundant outlets, M12\*1 closure plugs can be used to close them.

The Φ6 main line is connected with MG2J-M, and its outlet thread is M12x1, which is used in combination with PA-6 connector and PB-6 double cone ferrule. Its end port can be closed with PG06 closure plug.

Φ6 main line is connected with MG2J-R. Its outlet thread is Rc1/8, which can be used with straight connector. Its end port can be closed with Rc1/8 closure plug.

3. Made of aluminum alloy, the surface is anodized, and the appearance is beautiful.
4. Special requirements can be customized
5. According to the actual needs of the lubrication system, the connection blocks can be used in parallel or in series.

### Specification

Model	Outlets	L1	L2
MG2J-1R	1	33	22
MG2J-2R	2	49	38
MG2J-3R	3	65	54
MG2J-4R	4	81	70
MG2J-5R	5	97	86
MG2J-6R	6	113	102
MG2J-7R	7	129	118
MG2J-8R	8	145	134
MG2J-9R	9	161	150
MG2J-11R	11	177	166
MG2J-10R	10	193	182
MG2J-12R	12	209	198

### Dimension

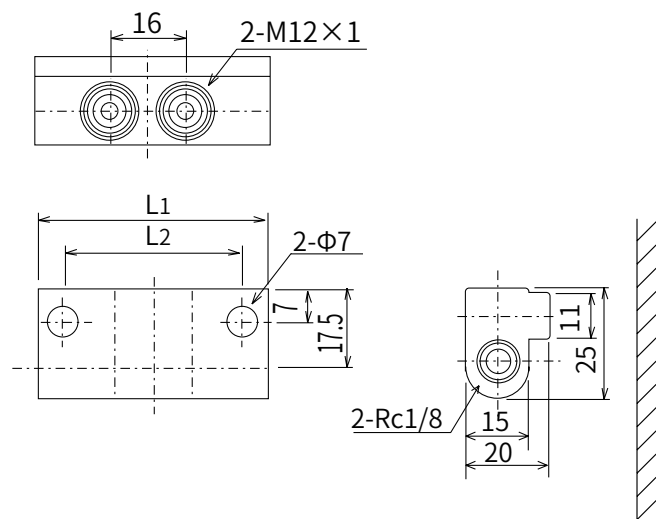

## ASL-43 Pressure-relief Metering Device

### Application

The distributor is used in a pressure relief lubrication system, and has the advantages of high lubricant pressure at the lubrication point, adjustable individual metering volume, strong resistance to backflow at the outlet, and simple system layout. It can be used in oil or grease systems with a few to hundreds of lubrication points.

### Component

Inside contains a pair of plungers and a pair of pistons. The plunger is responsible for controlling the piston to store and discharge lubricant. The stroke of the piston is adjustable, so as to realize the adjustment of the single lubricant storage. The distributor discharges the lubricant when the system is pressurized, and the lubricant is stored at the same time.

### Specification

Working pressure: 65~250bar

Residual pressure after system pressure relief:  $\leq 15$ bar

Measuring volume per outlet: 0.019~0.143mL/cyc

Oil viscosity range: 32~2000 Cst

Grease viscosity range: NLGI 000~1#

Working temperature: -25~80°C (120°C for special occasions)

Inlet thread: Rc1/8

Outlet connection:  $\Phi 4$ mm (nylon tube, copper tube, steel tube)



### Feature

The plunger hole and plunger are made of special heat-treated and precision-machined materials, which ensure the matching clearance and service life.

Piston seals are made of high-quality fluororubber seals, with a life of more than 100,000 operations and sufficient pressure resistance.

High machining accuracy makes it suitable for both oil and grease systems.

With any number of combinations of 2~10 outlets, it is more convenient to install the lubrication system.

The special structure of the outlet check valve is designed to resist the backflow of lubricants.

The metering volume adjustment is simple and easy to operate, and is equipped with a cap to lock.

Each action of the metering valve can be displayed on the indicator rod, which is convenient to observe action of the distributor.

A detection switch can be added to automatically monitor the working conditions of each metering valve.

## ASL-43 Pressure-relief Metering Device

### Product Selection

Production code	Model	Number of outlets	Outlet diameter
189013-2	ASL-43-2	2	4mm
189013-3	ASL-43-3	3	
189013-4	ASL-43-4	4	
189013-5	ASL-43-5	5	
189013-6	ASL-43-6	6	
189013-7	ASL-43-7	7	
189013-8	ASL-43-8	8	
189013-9	ASL-43-9	9	
189013-10	ASL-43-10	10	

### Dimension

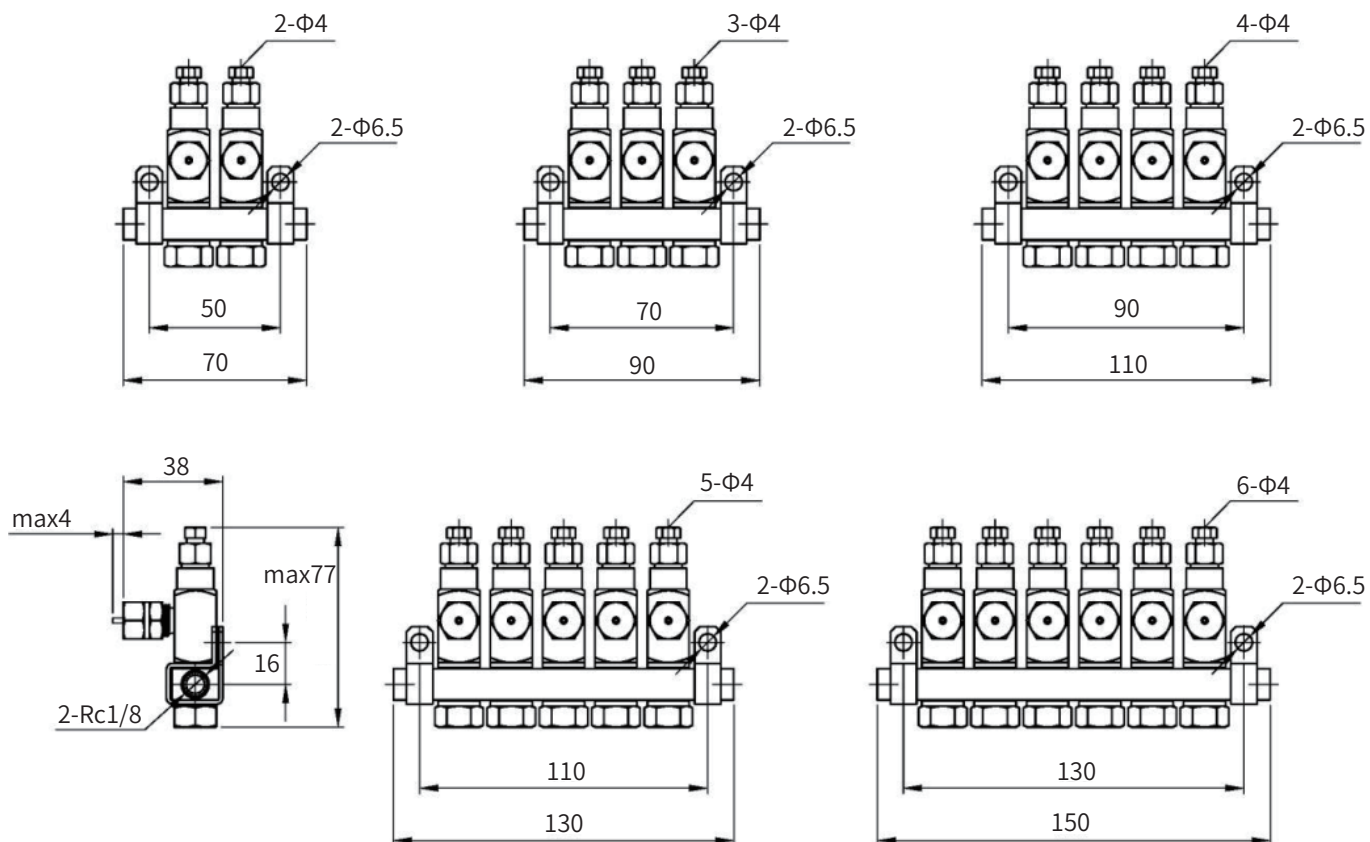

## Working process

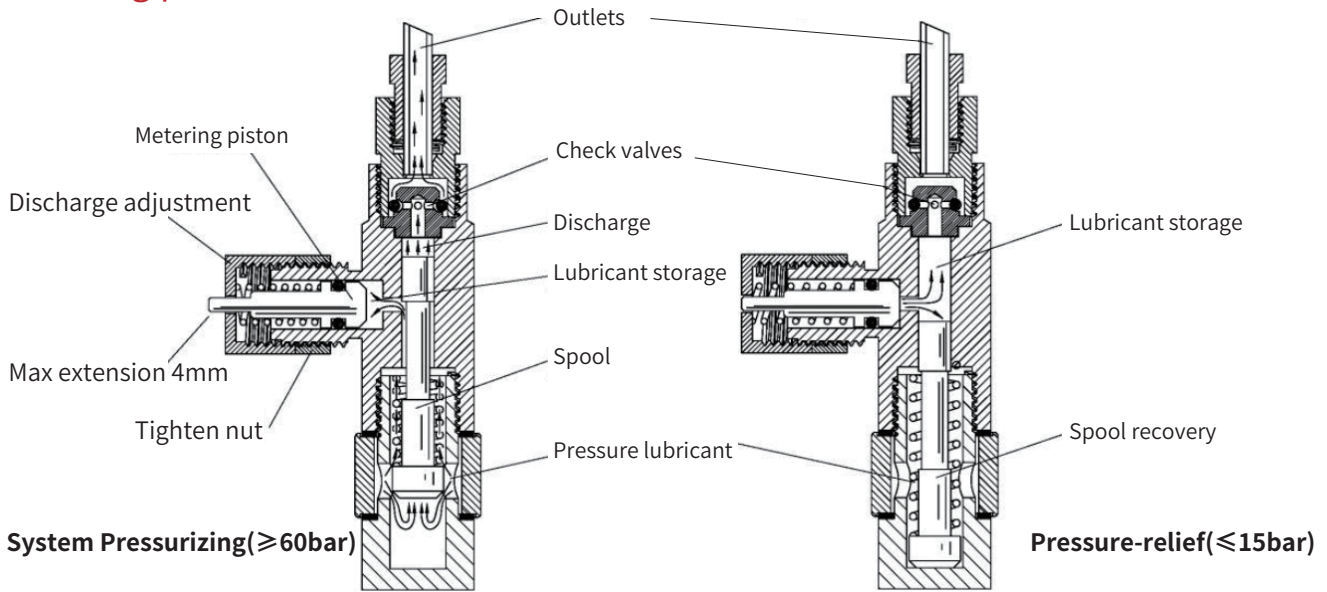

The high-pressure lubricant output by the pump pushes the valve core to move upward, and the lubricant stored in the upper part of the valve core and the valve body is discharged through the one-way valve. When the spool moves to the top, the inlet passage to the side piston opens and high pressure lubricant enters the piston. After the pump reaches the set pressure, it stops running and the system is depressurized. The spool is reset to the bottom under the action of an internal spring. Under the action of the spring, the metering piston discharges the lubricant between the valve core and the valve body, waiting for the next discharge. When the maximum single discharge is performed, the piston indicator rod is flush with the discharge adjustment nut (the system is depressurized), and the indicator rod extends up to 4mm. The discharge adjusting nut is screwed to the bottom for the minimum single discharge.

## Layout

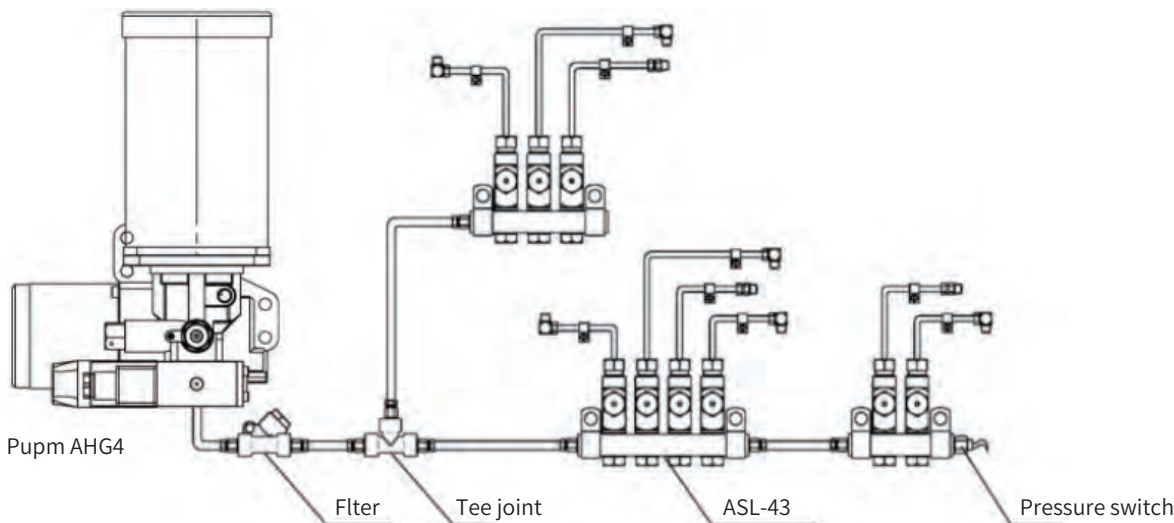

Since the viscosity of the lubricant varies greatly with the environment, it is recommended to configure a pressure switch at the end of the system pipeline and use the pressure control mode to ensure the discharge of each outlet. When installing the system, ensure the cleanliness of tubing and lubricants, preferably with filters.



## AVK1 Progressive Distributor

### Feature

The AVK1 distributor can be used for medium pressure and wide temperature changes. It can form a progressive lubrication system with manual, electric and pneumatic pumps. It is a distributor for various small machine tools and plastic machines or large lubrication systems.

A typical AVK1 distributor consists of start and end sections and 1 to 10 working section in the middle. AVK1 can provide lubrication for 3 to 24 lubrication points, the metering volume of each section can be different.

The left and right exits of the working section are not connected internally. Users can combine multiple outlets through 3-way or 4-way connectors to increase the metering volume or reduce the number of outlets, and cannot block any outlet.

### Specification

1. Maximum working pressure: 16 MPa.
2. Metering volume per outlet: 0.07mL/cyc, 0.16mL/cyc, 0.23mL/cyc, 0.32mL/cyc.
3. Lubricant range (at standard temperature): oil  $\geq$  ISO VG 68, grease NLGI 000#~2#.
4. Working ambient temperature: -20C~+80°C.
5. Pressure difference between outlets:  $\leq$ 5MPa.
6. The maximum cycle rate of plunger of mechanical cycle indicator: 60cyc/min.
7. The maximum circulation rate of the plunger: 200cyc/min.
8. Number of working sections: 3~12 pieces.
9. Lubrication points: 3~24 points.
10. Diameter and length of the best tube for working:  $\Phi$ 6mm, length 1.2~3.5m.
11. Valve body material and coating: carbon steel and zinc plated.

### AVK1 Dimension

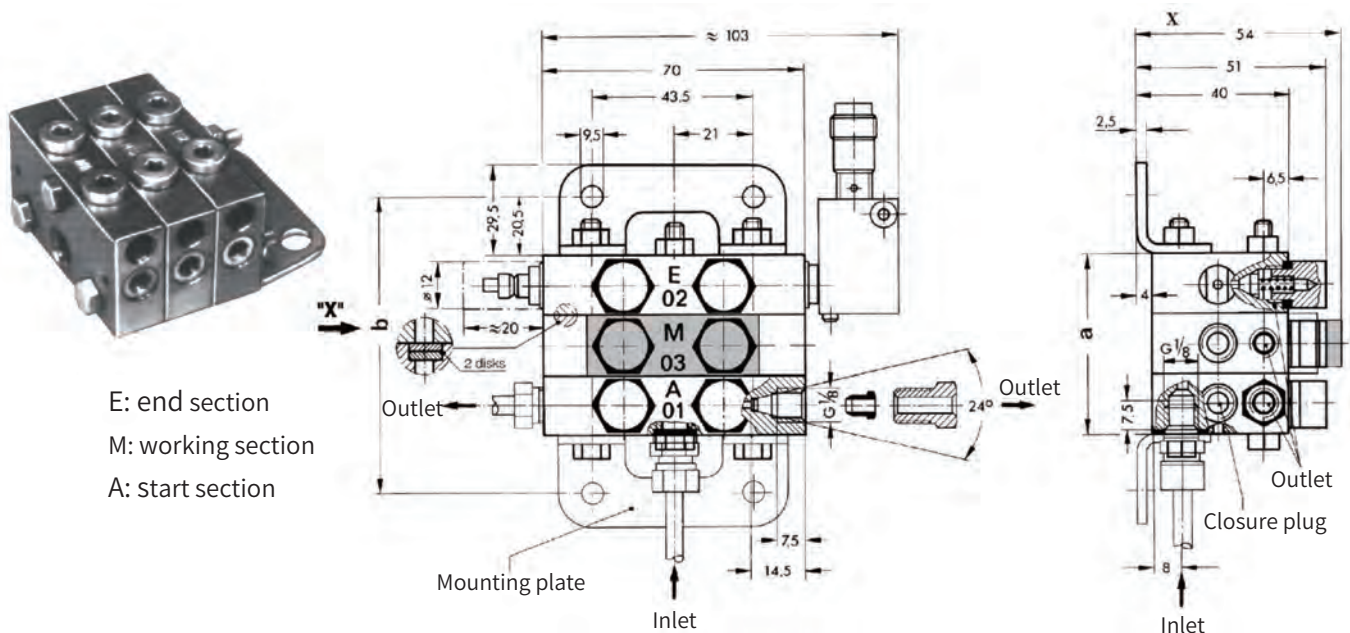



## Order code

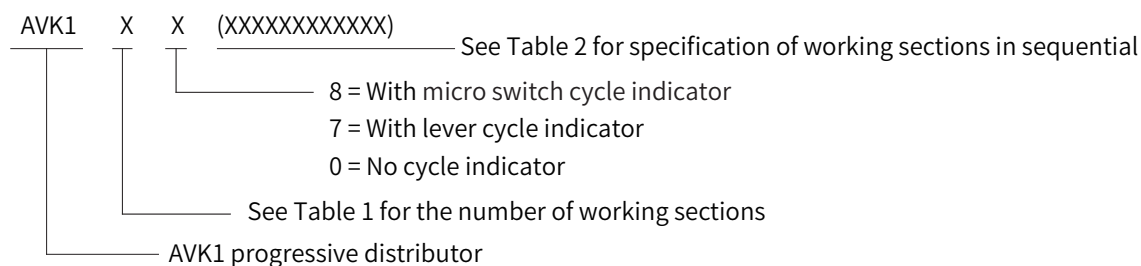

Code example : **AVK1-06-7-(0.16, 0.23, 0.07, 0.32-7R, 0.23, 0.07)**

R = right side, L = left side. 7L = left mounted micro switch cycle indicator.

Table 1

Mark	03	04	05	06	07	08	09	10	11	12
Quantity	3	4	5	6	7	8	9	10	11	12

Table 2

Mark	Metering volume
0.07	0.07mL/cycle/outlet (cycle indicator cannot be installed)
0.16	0.16mL/cycle/outlet
0.23	0.23mL/cycle/outlet
0.32	0.32mL/cycle/outlet

## AVK2 Progressive Distributor

### Feature

The AVK2 distributor can be used for medium pressure and wide temperature changes. It can form a progressive lubrication system with manual, electric and pneumatic pumps. It is a distributor for various small machine tools and plastic machines or large lubrication systems.

A typical AVK2 distributor consists of start and end sections and 1 to 10 working sections in the middle. AVK2 can provide lubrication for 3 to 24 lubrication points, the metering volume of each section can be different.

The left and right exits of the working section are not connected internally. Users can combine multiple outlets through 3-way or 4-way connectors to increase the metering volume or reduce the number of outlets, and cannot block any outlet.

### Specification

1. Maximum working pressure: 30 MPa.
2. Metering volume per outlet: 0.15, 1.2, 2.0mL/cyc.
3. Lubricant range: oil  $\geq$  ISO VG 68, grease NLGI 000#~2#.
4. Working ambient temperature: -20C~+80°C.
5. Pressure difference between outlets:  $\leq$ 5MPa.
6. Maximum cycle rate of lever cycle indicator: 60cyc/min.
7. Maximum cycle rate rate of the plunger: 200cyc/min.
8. Number of working sections: 3~12 pieces.
9. Lubrication points: 3~24 points.
10. Diameter and length of best hose:  $\Phi$ 6mm, 1.2~3.5m;  $\Phi$ 8mm, 1.5~4.5m.
11. Material and coating: carbon steel and zinc plated.

## AVK2 Dimension

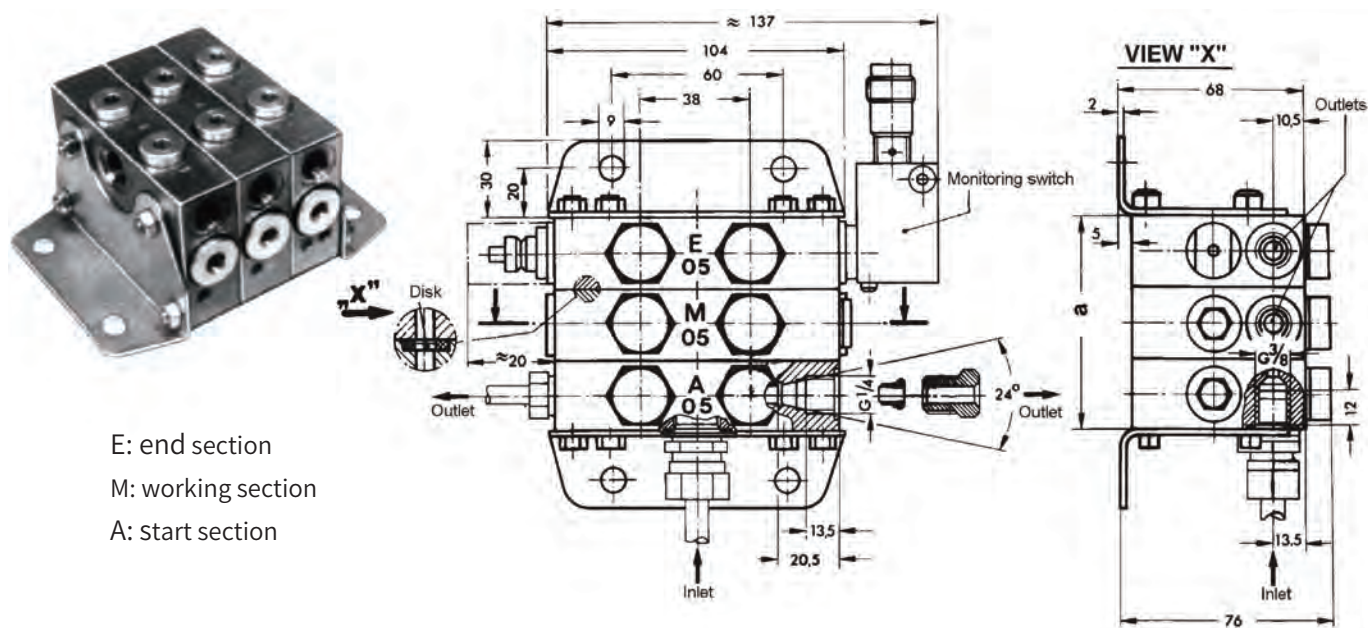

E: end section  
 M: working section  
 A: start section

## Order code

AVK2 X X (XXXXXXXXXX) — See Table 2 for working specification of sections in sequential

- 8 = With micro switch cycle indicator
- 7 = With lever cycle indicator
- 0 = No cycle indicator

See Table 1 for the number of working sections

AVK2 progressive distributor

Code example : **AVK2-06-8-(0.5, 1.2, 0.5, 1.2, 0.5, 2.0-8R)**

R = right side, L = left side. 8R = right mounted micro switch cycle indicator.

Table 1

Mark	03	04	05	06	07	08	09	10	11	12
Quantity	3	4	5	6	7	8	9	10	11	12

Table 2

Mark	Metering volume
0.5	0.5mL/cycle/outlet
1.2	1.2mL/cycle/outlet
2.0	2.0mL/cycle/outlet

## AVP1 Progressive Distributor

### Feature

The AVP1 distributor can be used for medium pressure and wide temperature changes. It can form a progressive lubrication system with manual, electric and pneumatic pumps. It is a distributor for various small machine tools and plastic machines or large lubrication systems.

A typical AVP1 distributor consists of start section, end section and 3 to 10 working sections in the middle. AVP1 can provide lubrication for 3 to 20 lubrication points, the metering volume of each section can be different. The left and right outlets of the working section are connected internally. In the marking of the working section, T = 2 outlets, on both sides of the working section, and S = 1 outlet. The left and right outlets of the working section are connected internally.

The number of outlets and metering volume of the distributor should be confirmed when ordering, otherwise the user can only combine the outlets through 3-way or 4-way connectors, and cannot block any outlets.

### Specification

1. Maximum working pressure: 16 MPa.
2. Metering volume per outlet: 0.08 mL/cyc ~ 0.48 mL/cyc.
3. Lubricant range (at standard temperature): oil  $\geq$  ISO VG 68, grease NLGI 000#~2#.
4. Ambient temperature: -20°C ~ +60°C (antifreeze grease at low temperature)
5. The maximum cycle rate of plunger of mechanical cycle indicator: 60cyc/min.
6. The maximum circulation rate of the plunger: 200cyc/min.
7. Number of working sections: 3~10 pieces.
8. Lubrication points: 3~20 points.
9. Diameter and length of the hose: length 0.5~2.5m( $\Phi$ 4), length 1.5~3.5m( $\Phi$ 6).
10. Valve body material and coating: carbon steel and zinc plated.



### Working Section

Item	Working section	Metering volume	Outlets per section	Max Pressure	Min Pressure	Inlet thread	Inlet diameter	Outlet thread	Outlet diameter
1	AVP1-05T	0.08mL/cyc	2	16 MPa	14 MPa	M10 x 1	$\Phi$ 6	M8 x 1	$\Phi$ 4
	AVP1-05S	0.16mL/cyc	1						
2	AVP1-10T	0.16mL/cyc	2						
	AVP1-10S	0.32mL/cyc	1						
3	AVP1-15T	0.24mL/cyc	2						
	AVP1-15S	0.48mL/cyc	1						

## AVP1 Dimension

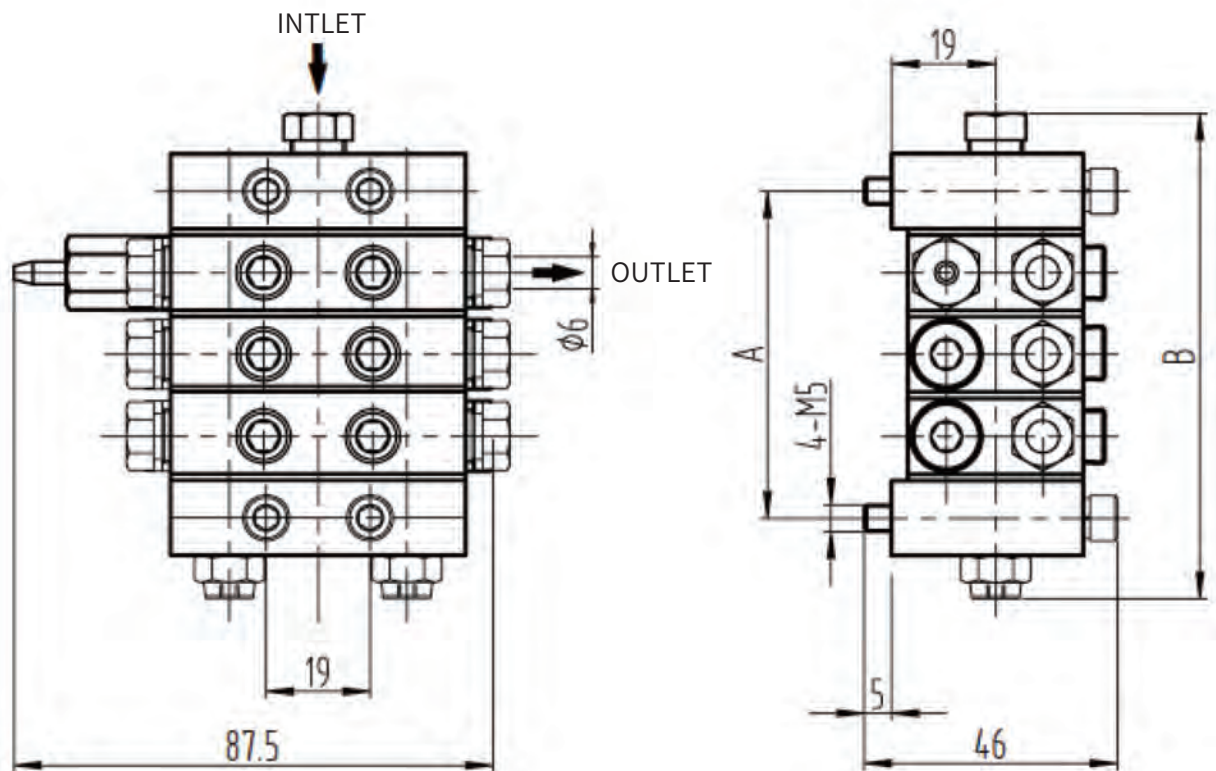

Working sections	A (mm)	B (mm)	Working sections	A (mm)	B (mm)
3	59.3	80.0	6	104.6	125.0
4	74.7	95.0	7	119.6	141.0
5	89.5	110.0	8	134.7	156.0

### NOTE

1. A cycle indicator can be installed on the AVP1 working section.
2. AVP1 is equipped with inlet and outlet fittings, if you want to change fittings, please specify when ordering.
3. Users should not block any outlet of AVP to avoid damage to the distributor due to overpressure.
4. A complete AVP distributor consists of at least one start section, one end section and 3 working sections.

## AVP1 Circuit Connector

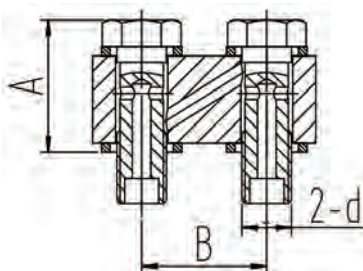

Model	Name	A(mm)	B(mm)	2-d
TDG0101	AVP1 circuit connector	19	15	2-G1/8

Mechanical lever indicators, micro switch type indicators, proximity switch type indicators and overpressure alarms are used in the same way as other AVP models.

## AVP2 Progressive Distributor

### Feature

The AVP2 distributor can be used for medium pressure and wide temperature changes. It can form a progressive lubrication system with manual, electric and pneumatic pumps. It is a distributor for various small machine tools and plastic machines or large lubrication systems.

A typical AVP2 distributor consists of start section, end section and 3 to 10 working sections in the middle. AVP2 can provide lubrication for 3 to 20 lubrication points, the metering volume of each section can be different. The left and right outlets of the working section are connected internally. In the marking of the working section, T = 2 outlets, on both sides of the working section, and S = 1 outlet.

The number of outlets and metering volume of the distributor should be confirmed when ordering, otherwise the user can only combine the outlets through 3-way or 4-way connectors, and cannot block any outlets.

### Specification

1. Maximum working pressure: 25 MPa.
2. Metering volume per outlet: 0.16 mL/cyc ~ 1.12 mL/cyc.
3. Lubricant range (at standard temperature): oil  $\geq$  ISO VG 68, grease NLGI 000#~2#.
4. Ambient temperature: -20°C ~ +60°C (antifreeze grease at low temperature)
5. The maximum cycle rate of plunger of mechanical cycle indicator: 60cyc/min.
6. The maximum circulation rate of the plunger: 200cyc/min.
7. Number of working sections: 3~10 pieces.
8. Lubrication points: 3~20 points.
9. Diameter and length of the hose: length 1.2~3.5m( $\Phi$ 6), length 1.5~4.5m( $\Phi$ 8).
10. Valve body material and coating: carbon steel and zinc plated.

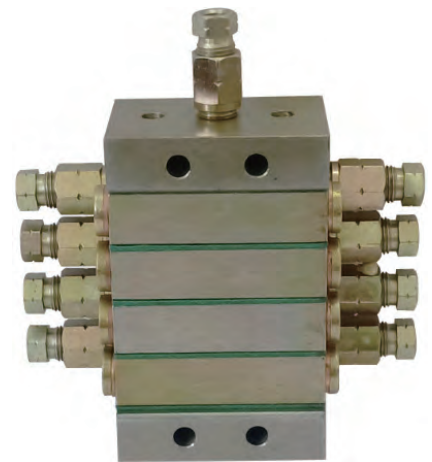

### Working Section

Item	Working section	Metering volume	Outlets per section	Max Pressure	Min Pressure	Inlet thread	Inlet diameter	Outlet thread	Outlet diameter
1	AVP2-10T	0.16 mL/cyc	2	25 MPa	14 MPa	M12x1.0	$\Phi$ 8	M10x1.0	$\Phi$ 6
	AVP2-10S	0.32 mL/cyc	1						
2	AVP2-15T	0.24 mL/cyc	2						
	AVP2-15S	0.48 mL/cyc	1						
3	AVP2-20T	0.32 mL/cyc	2						
	AVP2-20S	0.64 mL/cyc	1						
4	AVP2-25T	0.40 mL/cyc	2						
	AVP2-25S	0.80 mL/cyc	1						
5	AVP2-30T	0.48 mL/cyc	2						
	AVP2-30S	0.96 mL/cyc	1						
6	AVP2-35T	0.56 mL/cyc	2						
	AVP2-35S	1.12 mL/cyc	1						

## AVP2 Dimension

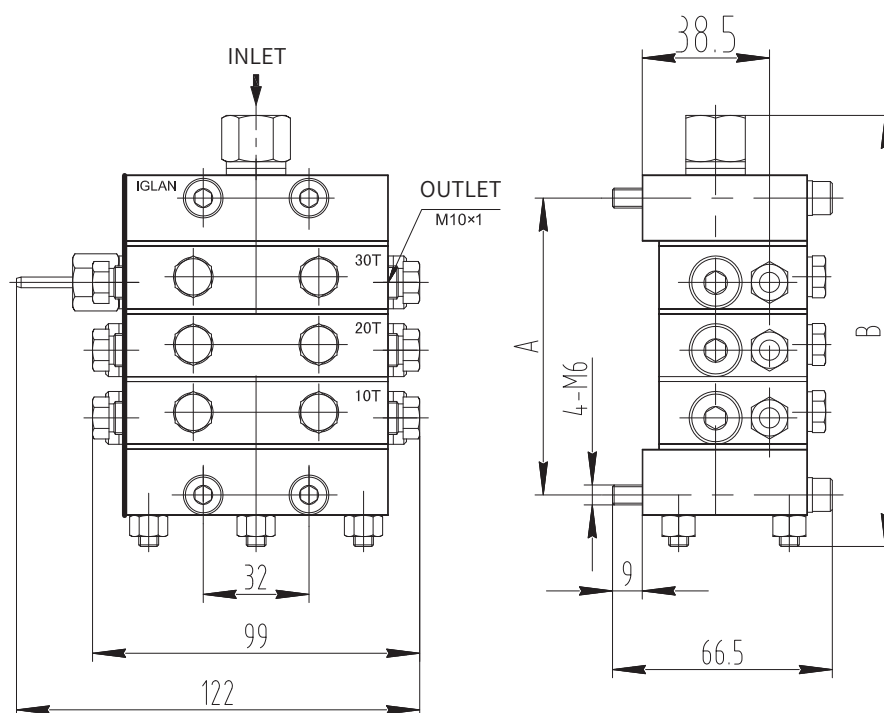

Working sections	A (mm)	B (mm)	Working sections	A (mm)	B (mm)
3	90	143	7	172	223
4	110.5	163	8	192.5	244
5	131	183	9	213	264
6	151.5	203	10	233.5	284

### NOTE

1. AVP2 working section of 20T or 20S and above can be equipped with a cycle indicator.
2. AVP2 is equipped with inlet and outlet fittings, if you want to change fittings, please specify when ordering.
3. Users should not block any outlet of AVP to avoid damage to the distributor due to overpressure.
4. A complete AVP distributor consists of at least one start section, one end section and 3 working sections.

## AVP2 Circuit Connector

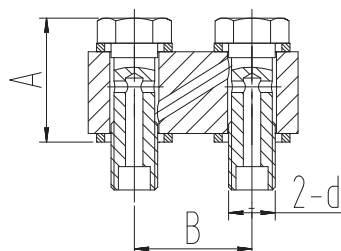

Model	Name	A(mm)	B(mm)	2-d
TDM88	AVP2 circuit connector	22	21	2-M8

Mechanical lever indicators, micro switch type indicators, proximity switch type indicators and overpressure alarms are used in the same way as other AVP models.



## AUV, AVP1, AVP2, AVP3 Order Configuration

It is best to let us know the metering volume for each outlet before confirming the order code.

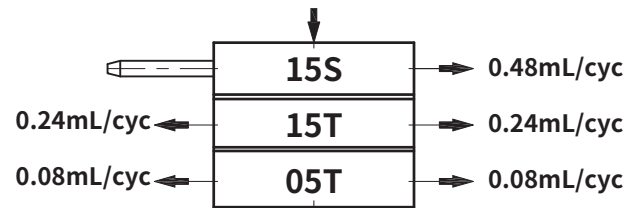

Order code  $\frac{\text{AVP1}}{\text{A}} - \frac{3}{\text{B}} - \frac{7}{\text{C}} - \frac{7}{\text{D}} \left( \frac{15\text{R-7L}}{\text{E}} \frac{15\text{T}}{\text{F}} \frac{05\text{T}}{\text{G}} \right)$

A = AVP1 series distributor.

B = number of working sections.

C = 7 = lever cycle indicator, 8 = micro switch cycle indicator, 9 = proximity switch cycle indicator, 0 = no cycle indicator.

D = start section.

E = 1st working section is marked 15S, R = right outlet, L = left outlet. 7L = left mounted lever cycle indicator.

F = 2nd working section is marked 15T.

G = 3rd working section is marked 05T.

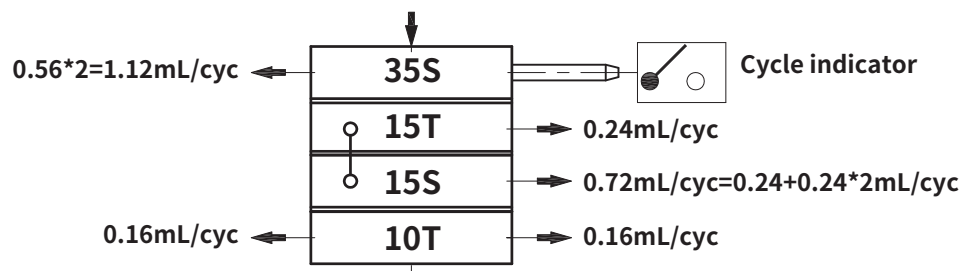

Order code  $\frac{\text{AVP2}}{\text{A}} - \frac{4}{\text{B}} - \frac{8}{\text{C}} - \frac{8}{\text{D}} \left( \frac{35\text{S-8R}}{\text{E}} \frac{\text{CF}15\text{T}}{\text{F}} \frac{15\text{SR}}{\text{G}} \frac{10\text{T}}{\text{H}} \right)$

A = AVP2 series distributor.

B = number of working sections.

C = 7 = lever cycle indicator, 8 = micro switch cycle indicator, 9 = proximity switch cycle indicator, 0 = no cycle indicator.

D = start section.

E = 1st working section is marked 35S, R = right outlet, L = left outlet. 8R = right mounted micro switch cycle indicator.

F = 2nd working section is marked 15T. Before 15, CF = left mounted circuit connector. After 15, CF = right mounted circuit connector. If two working sections are equipped with CF, only one of them is marked in the order code.

G = 3rd working section is marked 15S.

H = 4th working section is marked 10T.

## AVP3 Progressive Distributor

### Feature

The AVP3 distributor can be used for medium pressure and wide temperature changes. It can form a progressive lubrication system with manual, electric and pneumatic pumps. It is a distributor for various small machine tools and plastic machines or large lubrication systems.

A typical AVP3 distributor consists of start section, end section and 3 to 10 working sections in the middle. AVP3 can provide lubrication for 3 to 20 lubrication points, the metering volume of each section can be different. The left and right outlets of the working section are connected internally. In the marking of the working section, T = 2 outlets, on both sides of the working section, and S = 1 outlet.

The number of outlets and metering volume of the distributor should be confirmed when ordering, otherwise the user can only combine the outlets through 3-way or 4-way connectors, and cannot block any outlets.

### Specification

1. Maximum working pressure: 25 MPa.
2. Metering volume per outlet: 0.4 mL/cyc ~ 4.8 mL/cyc.
3. Lubricant range (at standard temperature): oil  $\geq$  ISO VG 68, grease NLGI 000#~2#.
4. Ambient temperature: -20°C ~ +60°C (antifreeze grease at low temperature)
5. The maximum cycle rate of plunger of mechanical cycle indicator: 60cyc/min.
6. The maximum circulation rate of the plunger: 200cyc/min.
7. Number of working sections: 3~10 pieces.
8. Lubrication points: 3~20 points.
9. Diameter and length of the hose: length 1.5~4.5m( $\Phi$ 8), length 1.8~5.5m( $\Phi$ 10).
10. Valve body material and coating: carbon steel and zinc plated.



### Working Section

Item	Working section	Metering volume	Outlets per section	Max Pressure	Min Pressure	Inlet thread	Inlet diameter	Outlet thread	Outlet diameter
1	AVP3-25T	0.40 mL/cyc	2	25 MPa	14 MPa	Rp3/8	$\Phi$ 10	Rp3/8	$\Phi$ 8
	AVP3-25S	0.80 mL/cyc	1						
2	AVP3-50T	0.80 mL/cyc	2						
	AVP3-50S	1.60 mL/cyc	1						
3	AVP3-75T	1.20 mL/cyc	2						
	AVP3-75S	2.40 mL/cyc	1						
4	AVP3-100T	1.60 mL/cyc	2						
	AVP3-100S	3.20 mL/cyc	1						
5	AVP3-125T	2.00 mL/cyc	2						
	AVP3-150S	4.00 mL/cyc	1						
6	AVP3-150T	2.40 mL/cyc	2						
	AVP3-150S	4.80 mL/cyc	1						

## AVP3 Dimension

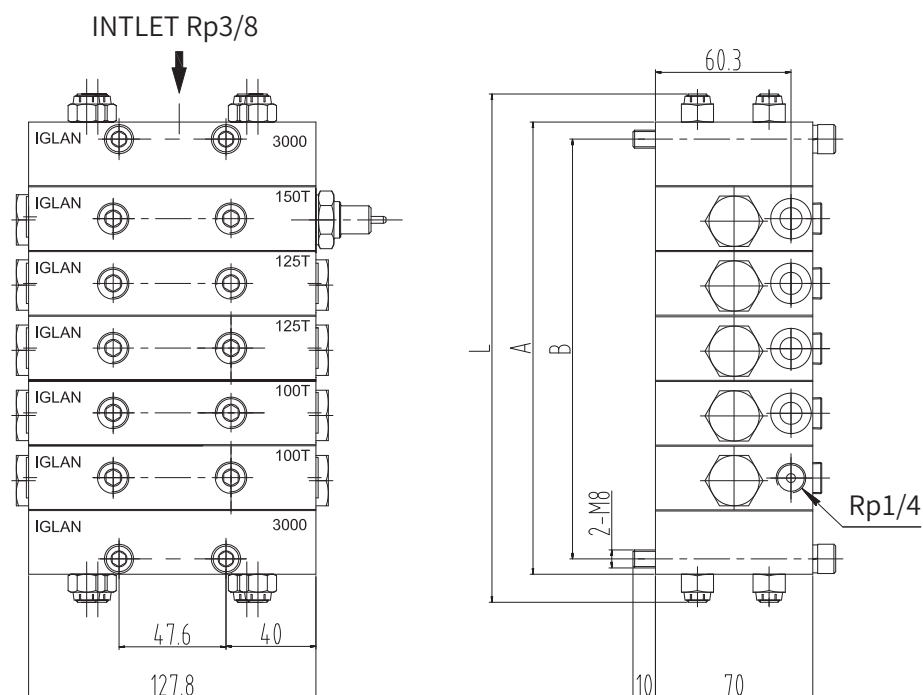

Working sections	A (mm)	B (mm)	Working sections	A (mm)	B (mm)
3	128.6	167.9	7	242.9	282.2
4	157.1	196.5	8	271.4	310.8
5	185.7	225	9	300	339.9
6	214.3	253.6	10	328.6	367.9

### NOTE

1. AVP3 working section of 50T or 50S and above can be equipped with a cycle indicator.
2. AVP3 is not equipped with inlet and outlet connectors, please specify when ordering if you need.
3. Users should not block any outlet of AVP to avoid damage to the distributor due to overpressure.
4. A complete AVP distributor consists of at least one start section, one end section and 3 working sections.

## AVP3 Circuit Connector

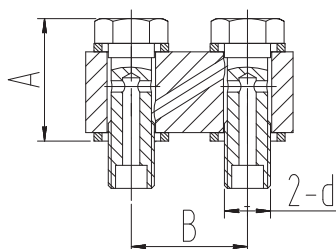

Model	Name	A(mm)	B(mm)	2-d
TDR0202	AVP3 circuit connector	24.5	28.5	2-G1/4

Mechanical lever indicators, micro switch type indicators, proximity switch type indicators and overpressure alarms are used in the same way as other AVP models.

## Mechanical lever cycle indicator



## Micro Switch Type Cycle Indicator

A microswitch-type cycle indicator is a device that monitors the flow of lubricant in the system. It utilizes the reciprocating motion of the indicator rod on the plunger in the progressive distributor to trigger the opening or closing of the micro switch, thereby sending electrical signals to the control system of the host. Once the lubrication system is abnormal, the control system of the host can issue an alarm or stop the system operation for timely maintenance.

Contact capacity: 250VAC 1A / 125VAC 3A



## Proximity Switch Type Cycle Indicator

An inductive proximity switch cycle indicator is a device that monitors the flow of lubricant in a system. It uses the indicator rod on the plunger in the progressive distributor to reciprocate. When the indicator rod moves to the front of the proximity switch induction, it is detected by the proximity switch and sends an electrical signal to the control system of the host. Once the lubrication system is abnormal, the control system of the host can issue an alarm or stop the operation of the lubrication system for timely maintenance. The proximity switch is a high-frequency oscillation type proximity switch, which has the advantages of high reliability, high precision, high switching frequency, and long life.



## Specification

1. DC three-wire type NPN type, rated voltage 24VDC ( $\pm 10\%$ ), PNP optional.
2. Sensing distance: 1.5mm; setting distance: 0-1.2mm.
3. Response frequency: 800HZ.
4. Protection class: IP67.
5. Protection circuit: power reverse connection protection circuit, interference protection circuit and overcurrent protection circuit.
6. Material: Housing is brass (chrome plated), sensing face is PTB resin.

## Pressure Alarm

The pressure alarm uses hydraulic transmission energy to act, and converts the lubricant pressure set by the system into mechanical visual signal or electrical switch signal. When the pressure of the lubrication system exceeds the set value, send out the mechanical visual signal or the electrical switch signal in time.

### Feature

1. Mechanical visual signal of overvoltage alarm, or electrical switch signal, contact capacity: 250VAC 1A / 125VAC 3A.
2. There are two types of pressure alarms: unloading and non-unloading. In the event of a failure of the unloading pressure alarm, the alarm will discharge the lubricant, while the distributor and its system are still running. Once the non-unloading pressure alarm is blocked, the distributor and its system will stop running.
3. Easy to install. Manual reset can only be done after the overpressure fault has been eliminated.

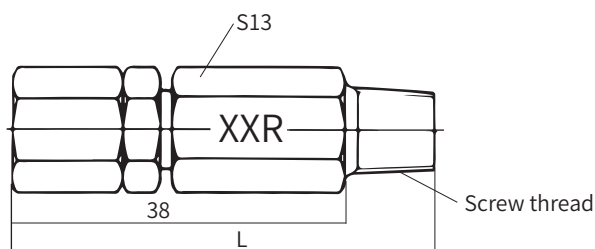

Item	Model	Thread	Distributor	L	Type	Alarm pressure
1	APA-4501	R1/8	AVP	48.3	Unloading	5 MPa
2	APA-4508	M8×1	AVP2, AVK	59.8		
3	APA-2501	R1/8	AVP	48.3	Non-unloading	
4	APA-2508	M8×1	AVP2, AVK	59.8		
5	APA-41001	R1/8	AVP	48.3	Unloading	10 MPa
6	APA-41008	M8×1	AVP2, AVK	59.8		
7	APA-21001	R1/8	AVP	48.3	Non-unloading	
8	APA-21008	M8×1	AVP2	59.8		
9	APA-41501	R1/8	AVP	48.3	Unloading	15 MPa
10	AAPA-41508	M8×1	AVP2, AVK	59.8		
11	APA-21501	R1/8	AVP	48.3	Non-unloading	
12	APA-21508	M8×1	AVP2	59.8		
13	APA-42001	R1/8	AVP	48.3	Unloading	20MPa
14	APA-42008	M8×1	AVP2	59.8		
15	APA-22001	R1/8	AVP	48.3	Non-unloading	
16	APA-22008	M8×1	AVP2	59.8		





## AVU Dimension

Working sections	M (mm)	L (mm)	Working sections	M (mm)	L (mm)
3	91	122	7	185	215
4	115	145	8	208	239
5	138	169	9	231	262
6	161	192	10	255	285

## Working section

Item	Working section	Metering volume	Outlets per section	Cycle indicator	Max Pressure	Min Pressure
1	AVU-05T	0.08 mL/cyc	2	-	25 MPa	14 MPa
	AVU-05S	0.16 mL/cyc	1	-		
2	AVU-10T	0.16 mL/cyc	2	-		
	AVU-10S	0.32 mL/cyc	1	-		
3	AVU-15T	0.24 mL/cyc	2	-		
	AVU-15S	0.48 mL/cyc	1	-		
4	AVU-20T	0.32 mL/cyc	2	M20TP		
	AVU-20S	0.64 mL/cyc	1	M20SP		
5	AVU-25T	0.41 mL/cyc	2	M25TP		
	AVU-25S	0.82 mL/cyc	1	M25SP		
6	AVU-30T	0.49 mL/cyc	2	M30TP		
	AVU-30S	0.98 mL/cyc	1	M30SP		
7	AVU-35T	0.57 mL/cyc	2	M35TP		
	AVU-35S	1.14 mL/cyc	1	M35SP		
8	AVU-40T	0.64 mL/cyc	2	M40TP		
	AVU-40S	1.28 mL/cyc	1	M40SP		

### NOTE

1. A cycle indicator can be installed on the working section.
2. If the user needs to change the diameter of the inlet and outlet pipes, please specify when ordering.
3. User should not block the outlet of AVP1 without permission to avoid damage to the distributor due to overpressure.
4. The minimum working section is 3 pieces and the maximum is 10 pieces.
5. For AUV order codes, the AVP series can be referenced, but AUV cycle indicator order code should be "M".

## ASV Progressive Distributor

### Feature

1. ASV progressive distributor through the plunger sequence action, progressive point by point in order to discharge.
2. The metering volume of each outlet in each cycle is 0.2mL.
3. One outlet can be blocked by a special closure plug, which doubles metering volume of the next outlet.
4. 6-20 outlets can be selected, outlets have one-way valves to prevent lubricant from flowing back.
5. Easy to monitor, visual monitoring or electronic monitoring. It is easy to replace and does not affect other pipelines.
6. Applicable lubricants: grease NLGI 000# ~ 2#, oil 32-220cSt@40°C.
7. The operating temperature is -20°C~+80°C.

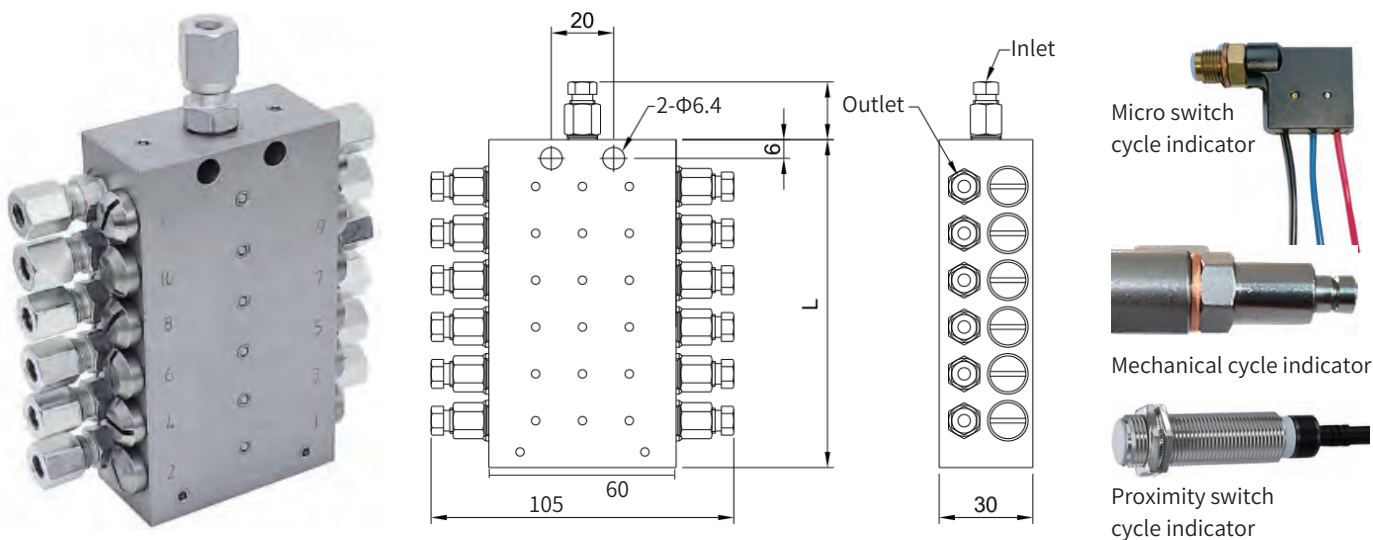

### Specification

Model	Outlets	L(mm)	Weight(kg)	Inlet dia.	Outlet dia.	Metering volume	Pressure
ASV-6	6	60	0.9	Φ6 or Φ8	Φ6	0.2mL/outlet/cycle	Grease 1.5~30MPa
ASV-8	8	75	1.2				
ASV-10	10	90	1.4				
ASV-12	12	105	1.6				
ASV-14	14	120	1.8				
ASV-16	16	135	2.1				
ASV-18	18	150	2.2				
ASV-20	20	165	2.5				

### Order code

<b>ASV</b>	<b>—</b>	<b>6</b>	<b>—</b>	<b>01</b>	<b>—</b>	<b>8</b>	<b>—</b>	<b>6</b>	<b>—</b>	<b>S</b>
		<b>Outlets</b>		<b>Detector</b>		<b>Inlet</b>		<b>Outlet</b>		<b>Hose fittings</b>
		6 = 6 outlets		01 = No indicator		6 = Φ6		6 = Φ6		F = Push-in type
		8 = 8 outlets		02 = Mechanical cycle indicator		8 = Φ8				S = Screw-in type
		.....		03 = Micro switch cycle indicator						
		20 = 20 outlets		04 = Proximity switch cycle indicator						

## ASVB Progressive Distributor

### Feature

1. The ASVB distributor acts through the plunger, and each outlet discharges the lubricant in sequence.
2. The metering volume of each outlet in each cycle is 0.2 mL.
3. Optional visual indicator rod monitoring or electronic signaling monitoring.
4. No outlet can be blocked, the outlet can be combined with a three-way or four-way connector.
5. There are 6-20 outlets to choose from. The maximum number of cycles is 200/min.
6. 30-200bar is used for oil system, 300bar is used for grease system.
7. Applicable lubricants: grease NLGI 000#-2#, oil 32-220cSt@40°C.
8. Operating temperature: -20°C~+80°C.

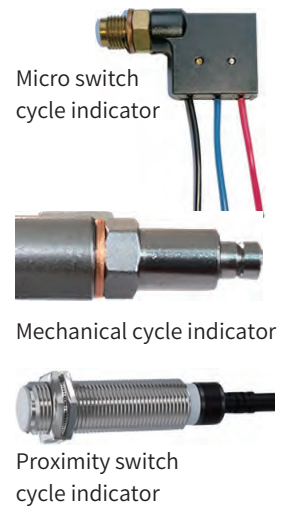
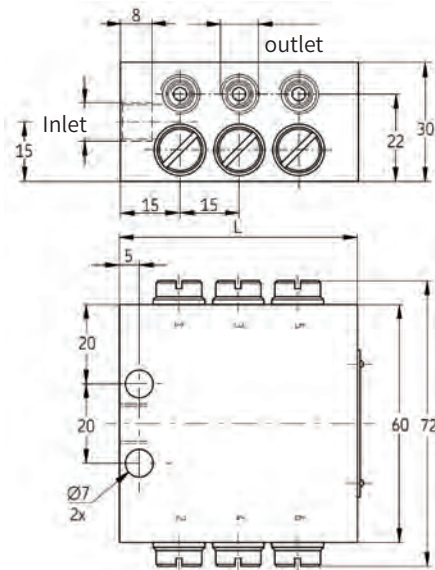

### Specification

Model	Outlets	L(mm)	Weight(kg)	Inlet dia.	Outlet dia.	Metering volume	Pressure
ASVB-6	6	60	0.9	Φ6 or Φ8	Φ6 or Φ4	0.2mL/outlet/cycle	Grease 1.5~30MPa
ASVB-8	8	75	1.2				
ASVB-10	10	90	1.4				
ASVB-12	12	105	1.6				
ASVB-14	14	120	1.8				
ASVB-16	16	135	2.1				
ASVB-18	18	150	2.2				
ASVB-20	20	165	2.5				

### Order code

<b>ASVB</b>	<b>—</b>	<b>6</b>	<b>—</b>	<b>01</b>	<b>—</b>	<b>8</b>	<b>—</b>	<b>6</b>	<b>—</b>	<b>S</b>
		<b>Outlets</b>		<b>Detector</b>		<b>Inlet</b>		<b>Outlet</b>		<b>Hose fittings</b>
		6 = 6 outlets		01 = No indicator		6 = Φ6		4 = Φ4		F = Push-in type
		8 = 8 outlets		02 = Mechanical cycle indicator		8 = Φ8		6 = Φ6		S = Screw-in type
		.....		03 = Micro switch cycle indicator						
		20 = 20 outlets		04 = Proximity switch cycle indicator						

## Elastic Grease Cartridge

Ordercode **GF1-0-07**

00	NLGI 00#	04	400ml reservoir
0	NLGI 0#	07	700ml reservoir
1	NLGI 1#		
2	NLGI 2#		



### Feature

1. The cartridge is used with AGHS, EGM series grease pump.
2. The applicable temperature range of grease is -25°C~130°C.
3. This product has high dropping point, strong compressive performance, good lubricating effect, good mechanical stability and colloidal stability.
4. Compared with refilling, the cartridge can be replaced directly, which is easy to operate, environmentally friendly.
5. Applicable industries: lubrication systems in plastics, food, industrial robots, metal cutting machine tools, forging, automotive chassis and other industries.

ITEMS	GF	GF1
Appearance	Orange uniform grease	Green uniform grease
Dropping point °C	170	180
Base oil freezing point °C	-25	-25
Penetration 0.1mm	450-380	310-340
Corrosion (T2 copper sheet, 100°C, 24h)	No green or black change in copper	
Corrosion resistance (52°C, 24h)	1	1
Water leaching loss (38°C, 1h), (mass fraction%)	2	2
Roller stability, 4h cone penetration difference, 0.1mm	40	45
Similar viscosity (-10°C, 10S-1), Pa s	90	220
Extreme pressure performance (four-ball machine method) PB/N	800	900
Impurities (microscopy), pcs/cm <sup>3</sup>	25µm	2500
	75µm	400
	100µm	0

### Note

1. The cartridge is a one-time product, it is strictly forbidden to refill it after use.
2. During storage and use, dust and impurities should be prevented from mixing.
3. Do not mix with other lubricants, otherwise physical or chemical reactions may occur and performance will be reduced.
4. Avoid direct sunlight during storage and use.

### Magnetic Spring Current Detector

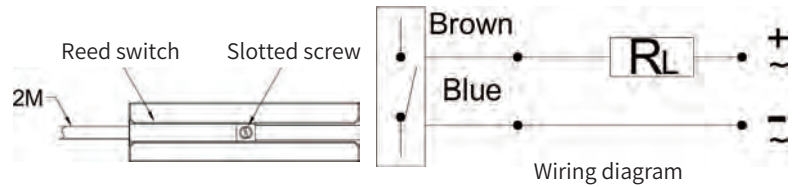
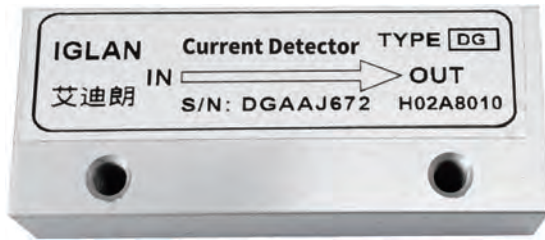

Model	Specs
DG10D001	NO contact /0.1a/ with light
DG10D002	NO contact /0.5a/ with light
DG11D001	NC contact /0.1a/ with light
DG11D002	NC contact /0.5a/ with light

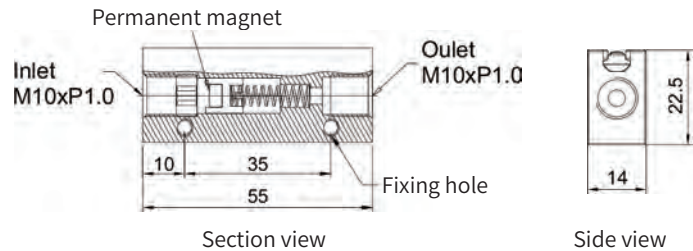

### Function

Its main function is to detect whether there is lubricant flowing in the pipeline. When it detects no lubricant flowing or no lubricant in the line, the pump starts and drives the lubricant. The lubricant pushes the permanent magnet in the current detector, and the permanent magnet is displaced, and the reed switch will receive the contact switching action generated by the magnetic induction of the magnet. The passage of lubricant is detected. And when the pump is stopped, the permanent magnet will return to the original position due to the rear end compression spring.

### Feature

1. The reed switch is used for contact switching without contact with the oil.
2. The position of the reed switch can be adjusted and will not loosen due to vibration.
3. When the pipeline is blocked by foreign matter, it can be removed immediately.
4. It can detect lower flow.
5. Simple structure and small contact area of moving parts.
6. Suitable for resistance system and oil circulation system.

### Specification

Maximum flow through: 500cc/min

The lowest sense side flow: 50cc/min

Oil used: 32~90cst@40°C

Maximum pressure: 15bar

Installation angle: unlimited

Weight: 90g

Current maximum load (series load): 0.5A

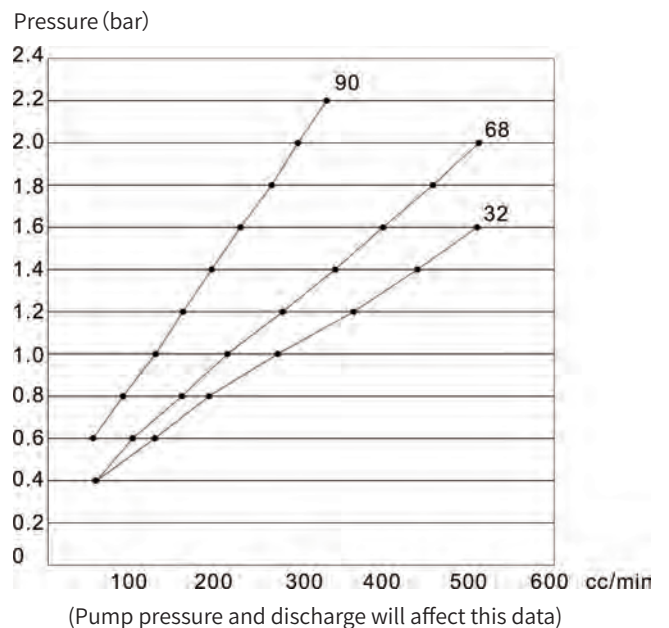

## Oil Auto Cleaner

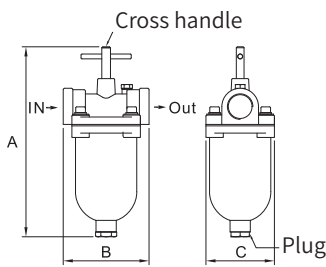

Model	SPEC	A	B	C	N.W(g)	Accuracy	Pressure
A-102	PT1/4xPT1/4	160	76	60	750	80mesh or 100mesh	25 bar
A-103	PT3/8xPT3/8	160	76	60	750		
A-104	PT1/2xPT1/2	200	89	71	1150		
A-106	PT3/4xPT3/4	236	120	85	1900		
A-110	PT1xPT1	270	120	85	2200		
A-115	PT1½xPT1½	370	145	100	4000		

## Oil Filter

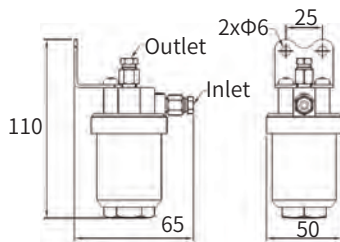

Model	Pressure	Discharge	Accuracy	Inlet&outlet	N.W
A-101	Max 30 bar	Max 2.5L/min	40μ	PT1/8	420g

## Filter Double Joint

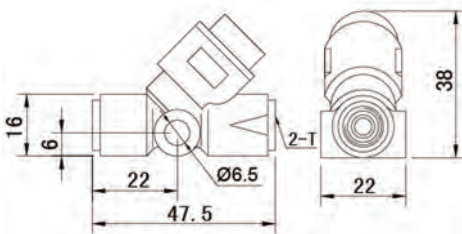

Model	AFY-04	AFY-06
SPEC	Φ4 x Φ4	Φ6 x Φ6
T	M8x1.0	M10x1.0
Accuracy(μ)	20	20
Pressure	25 bar	25 bar
Use	Resistance type	Resistance type
Max discharge	1L/min	1L/min
Viscosity	30-250cSt	30-250cSt

## Grease Filter

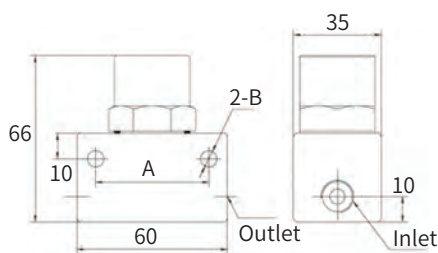

Model	Hose	Accuracy	Pressure	Inlet&outlet	A	B	N.W
LYQ3-6	Φ6	120μ	20MPa	Rap1/8	30	Φ4.5	322g
LYQ3-8	Φ8	120μ	20MPa	Rap1/8	40	Φ5.5	322g
LYQ3-10	Φ10	120μ	20MPa	Rap1/4	45	Φ6.5	322g
LYQ-6	Φ6	120μ	20MPa	Rap1/8	30	Φ4.5	330
LYQ-8	Φ8	120μ	20MPa	Rap1/8	40	Φ5.5	330
LYQ-10	Φ8	120μ	20MPa	Rap1/4	45	Φ6.5	330

## Grease Nipple

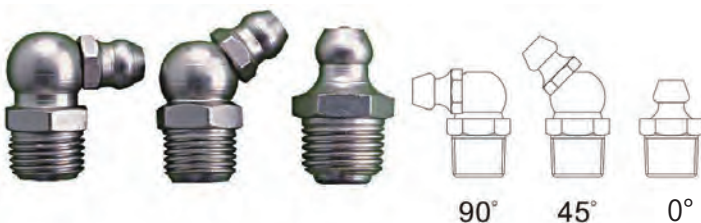

Model	External thread	N.W(g)
PJ-000600	M6xP1.0	0°
PJ-000645	M6xP1.0	45°
PJ-000690	M6xP1.0	90°
PJ-000800	M8xP1.0	0°
PJ-000845	M8xP1.0	45°
PJ-010890	M8xP1.0	90°
PJ-010100	PT1/8	0°
PJ-010145	PT1/8	45°
PJ-010190	PT1/8	90°



## Pressure Switch



Model	Contact	On Pressure	Off Pressure	Thread
PS0120808	N.O	1.2kg/cm <sup>2</sup>	0.8kg/cm <sup>2</sup>	M8x1.0
PS030808	N.O	3kg/cm <sup>2</sup>	1kg/cm <sup>2</sup>	M8x1.0
PS100808	N.O	10kg/cm <sup>2</sup>	5kg/cm <sup>2</sup>	M8x1.0
PS171208	N.O	17kg/cm <sup>2</sup>	12kg/cm <sup>2</sup>	M8x1.0
PS302510	N.O	30kg/cm <sup>2</sup>	25kg/cm <sup>2</sup>	M10x1.0
PS554010	N.O	55kg/cm <sup>2</sup>	40kg/cm <sup>2</sup>	M10x1.0
PC051008	N.C	5kg/cm <sup>2</sup>	10kg/cm <sup>2</sup>	M8x1.0
PC081208	N.C	0.8kg/cm <sup>2</sup>	1.2kg/cm <sup>2</sup>	M8x1.0
P3040	N.O	40kg/cm <sup>2</sup>	30kg/cm <sup>2</sup>	M10x1.0
PC121708	N.C	17kg/cm <sup>2</sup>	12kg/cm <sup>2</sup>	M8x1.0

## Level Switch

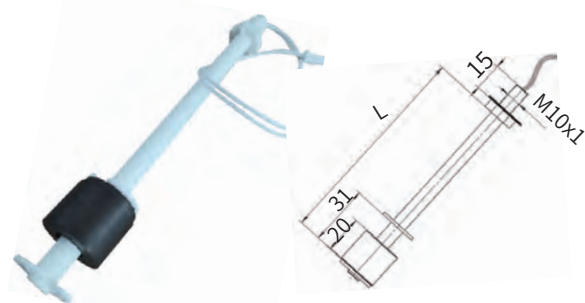

Model	L	Contact	Power	Voltage	Current	Thread	TEMP
F120	120mm	NC	10W	220V	1.5A	M10x1	-20~90°C
F140	140mm	NO					

## Horizontal Pressure Gauge

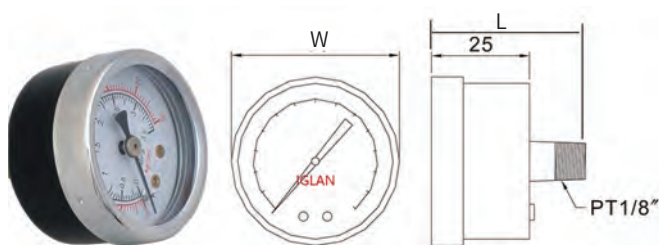

Model	SPEC	W(mm)	L(mm)	Remark
MF-15	15 bar	42	38	Dry
MF-40	40 bar			
MFB-40	40 bar	47	45	With oil
MFB-60	60 bar			
MFB-100	100 bar			
MFB-160	160 bar	47	45	

## Vertical Pressure Gauge

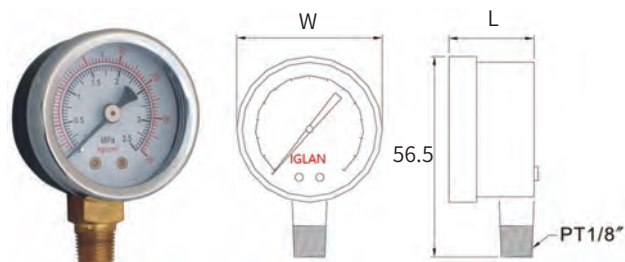

Model	SPEC	W(mm)	L(mm)	Remark
M-15	15 bar	40	38	Dry
M-40	40 bar			
MB-40	40 bar	47	60	With oil
MB-60	60 bar			
MB-100	100 bar			
MB-250	250 bar	58	75	With oil
MB-400	400 bar			
MB-600	600 bar			

## Screw Cap Oil Cup

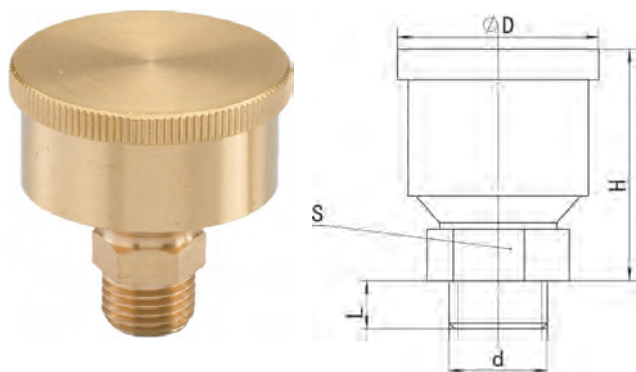

Model	D(mm)	d(mm)	L(mm)	S(mm)	H(mm)	Capacity(mL)
RYB-110A	16	M10x1.0	8	12	29	1.5
RYB-110B	20	M10x1.0	8	14	31	3
RYB-110C	26	M10x1.0	8	14	35	6
RYB-114A	32	M14x1.5	10	17	40	12
RYB-114B	36	M14x1.5	10	17	43	18
RYB-114C	41	M14x1.5	10	19	46	25
RYB-116A	50	M16x1.5	12	22	59	50
RYB-116B	63	M16x1.5	12	24	69	100

## Press Fit Oil Cup

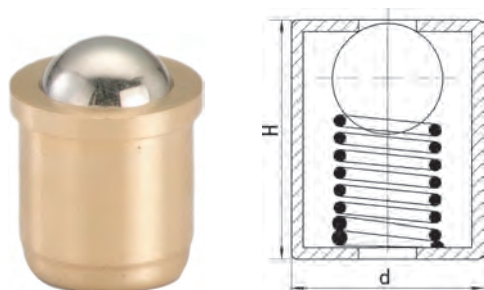

Model	D(mm)	H(mm)	Steel ball	Remark
PYB-106	6	6	4	-
PYB-108	8	10	5	-
PYB-110	10	12	6	-
PYB-116	16	20	11	-
PYB-125	25	3.0	13	-

## Spring Lid Right Angle Oil Cup

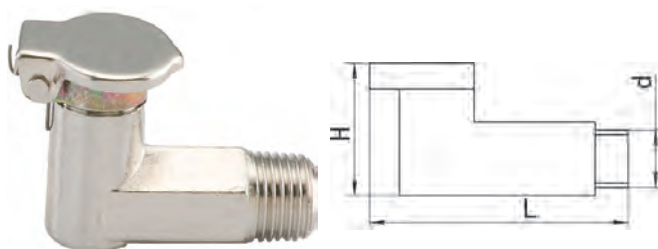

Model	D(mm)	L (mm)	H(mm)	S(mm)
AYB-306	M6x1.0	24	18	8
AYB-308	M8x1.0	28	24	10
AYB-310	M10x1.0	28	24	10
AYB-318	R1/8	28	24	10
AYB-318L	R1/8	34.5	24	10

## Spring Cap Oil Cup

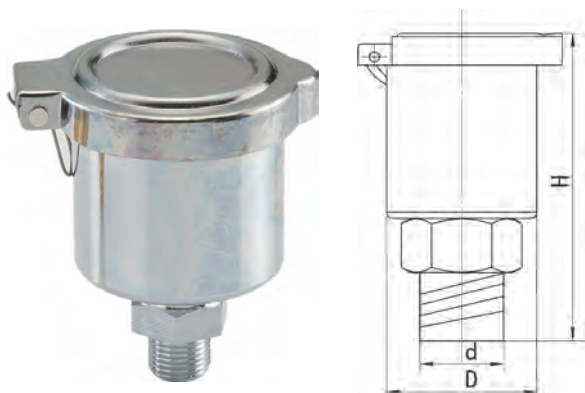

Model	D(mm)	d (mm)	H(mm)	Capacity(mL)
AYB-106	9	M6x1.0	20	1
AYB-108	10	M8x1.0	21	1
AYB-110A	16	M10x1.0	32	1.5
AYB-110B	20	M10x1.0	39	3
AYB-114A	25	M14x1.5	50	6
AYB-114B	30	M14x1.5	56	12

## Oil Cup



Model	Threadxdia(PTxD)	Model	Threadxdia(PTxD)	Model	Threadxdia(PTxD)	Model	Threadxdia(PTxD)
OC101	1/8" x1"	OC201	1/4" x1"	OC301	3/8" x1-1/2"	OC401	1/2" x2"
OC102	1/8" x1-1/4"	OC202	1/4" x1-1/4"	OC302	3/8" x2"	OC402	1/2" x2-1/2"
OC103	1/8" x1-1/2"	OC203	1/4" x1-1/2"	OC303	3/8" x1-1/2"	OC403	1/2" x3"
OC104	1/8" x2"	OC204	1/4" x2"	OC304	3/8" x2"	OC404	1/2" 4"
OC105	1/8" x3"	OC205	1/4" x2-1/2"	OC305	3/8" x4"		
		OC206	1/4" x3"				
		OC207	1/4" x4"				

D: Acrylic oil cup diameter

## High Pressure Universal Nozzle



CS - PT - 1/8 - 45 - 30

CS	Universal nozzle
PT	Thread PT(mm)
1/8	Size 1/8 1/4 3/8 1/2 10
1/8	Length 20 30 40 50 60 70
180	Angle 180°
30	Angle 30°
45	Angle 45°

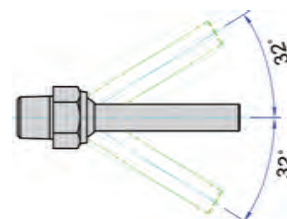
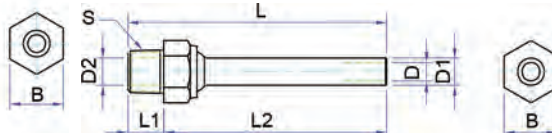
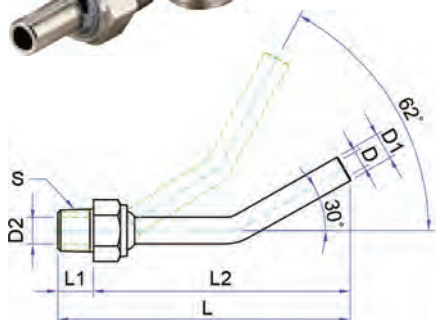

## Specification

Model	D	D1	D2	L	L1	L2	S
CSPT-1/8 (L2)	φ4	φ6	φ6	8+L2	8	20 40 60	1/8PT
CSPT-1/4 (L2)	φ4	φ6	φ6	10+L2	10	20 40 60	1/4PT
CSPT-3/8 (L2)	φ6	φ8	φ8	12+L2	12	30 50 70	3/8PT
CSPT-1/2 (L2)	φ6	φ8	φ8	13+L2	13	30 50 70	1/2PT
CSPT-1/8 (L2) -30	φ4	φ6	φ6	8+L2	8	40 60	1/8PT
CSPT-1/4 (L2) -30	φ4	φ6	φ6	10L2	10	40 60	1/4PT
CSPT-3/8 (L2) -30	φ6	φ8	φ8	12+L2	12	50 70	3/8PT
CSPT-1/2 (L2) -30	φ6	φ8	φ8	13+L2	13	50 70	1/2PT

## High Pressure Hose Assembly



Order code **PSH-4-KD-X-N**

4	Φ4 fittings
6	Φ6 fittings
8	Φ8 fittings
10	Φ10 fittings

N	No spring cover
T	With spring cover
X	Hose length X (mm)
KD	Straight fittings
KH	Elbow fittings

### Feature

1. It is composed of composite resin hose and detachable connector, and the length can be customized.
2. The installation is simple. Dip the connector with a little lubricant, screw it vertically into the hose and tighten the nut.
3. The hose is made of three layers: inner layer PA11, reinforcing layer polyester fiber and outer layer polyurethane.
4. It is applicable to the occasion where the lubrication point moves. The spring protective sleeve can be added.
5. Temperature range is -40 °C +80 °C, maximum bearing pressure 35MPa.

### Dimension

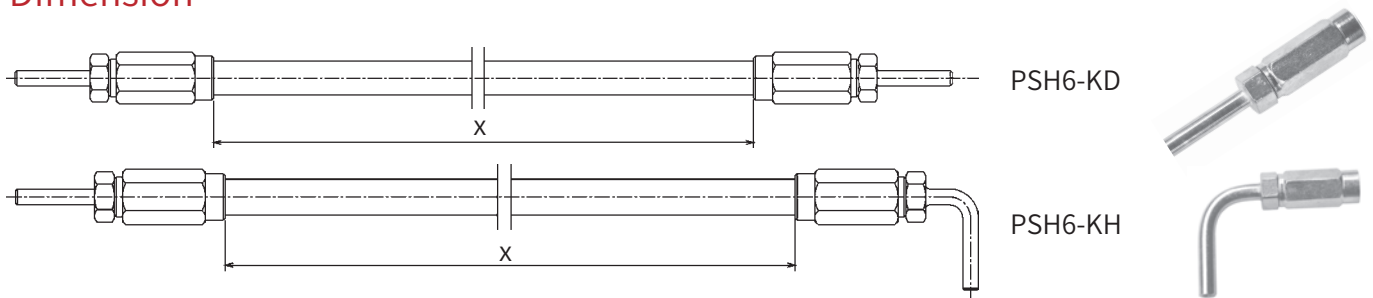

### Straight fittings

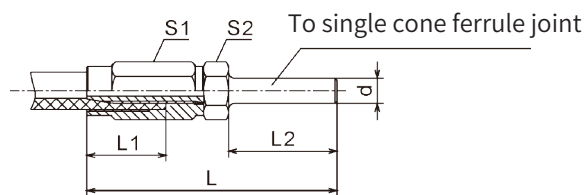

### KD specification

Model	d	L1	L2	L	S1	S2	Hose
KD-4	Φ4	19	20	53	12	12	Φ4*8.6
KD-6	Φ6	19	26	60	12	12	Φ4*8.6
KD-8	Φ8	19	26	60	12	12	Φ6.3*11.3
KD-10	Φ10	19	30	63	12	12	Φ6.3*11.3

### Elbow fittings

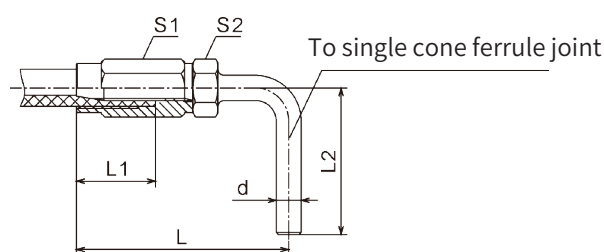

### KH specification

Model	d	L1	L2	L	S1	S2	Hose
KH-6	Φ6	19	35	51	12	12	Φ4*8.6
KH-8	Φ8	19	48	54	12	12	Φ6.3*11.3

## High-pressure Hose

Order code **HGH40 - X**

HGH40	hose 4.0*8.6mm	X	hose length X (mm)
HGH60	hose 6.3*11.3mm		



## Specification

Model	Thickness	Hose I.D.	Hose O.D.	Hose weight	Length	Temperature	Pressure
HGS40	2.3mm	4.0mm	8.6mm	53g/meter	200meters/roll	-40 °C +80 °C	Max 35MPa
HGS63	2.45mm	6.3mm	11.3mm	78.5g/meter			

Hose consists of an inner tube (nylon PA11), a middle layer (synthetic fiber) and an outer layer (flexible polyurethane). It is light and soft, inner is smooth, resistance of medium flow is small, and it has good chemical and impact resistance.

## Hose Fittings

Dimension	Model	D	L	L1	S	Connecting hose
	KD1-1	4	50	24	8	HGH40
	KD1-2	6	60	26	10	HGH40
	KD1-3	6	60.5	30	10	HGH40
	KD1-4	8	60	26	12	HGH63
	KD1-5	10	71.5	33	8	HGH63
	KH1-1	4	42	20	8	HGH40
	KH1-2	6	42	33	10	HGH40
	KH1-3	6	47	34.5	10	HGH40
	KH1-4	8	47	38	12	HGH63
	KH1-5	10	53	42	14	HGH63
	KN1-1	8.3	28.5	-	10	HGH40
	KN1-2	8.3	28.5	-	12	HGH40
	KN1-3	11	30	-	14	HGH63
	KN1-4	13.8	30	-	21	HGH63

## Hose Connection

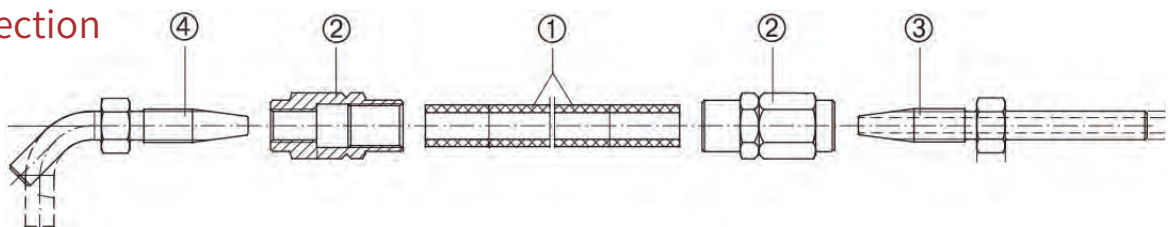



Hose with Spring



Ordercode

P S T - 4 - X - T - S

4	Φ4 diameter
6	Φ6 diameter
X	Length X

X	With fittings
N	No Spring Sleeve
T	With Spring Sleeve

Feature

1. It is composed of composite rubber hose, spring sheath and crimped joint.
2. The length of the hose can be customized, and the applicable temperature range is -20°C~+80°C.
3. It is suitable for lubricant delivery of moving parts and cutting parts of equipment.

Specification

Model		PST-4	PST-6
Outer diameter	d	Φ4	Φ6
Max. pressure	MPa	10	15
Min. bending radius	mm	R20	R40
X	mm	Customized	

Dimension

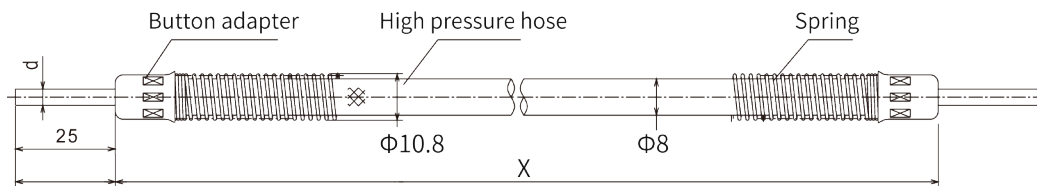

Spring Cover of Nylon Tube



Model	Diameter	Diameter x Length	Weight(g)
NPS-42000	Φ4.5	Φ4.5x2000mm	95
NPS-44000	Φ4.5	Φ4.5x4000mm	190
NPS-62000	Φ6.5	Φ6.5x2000mm	160
NPS-64000	Φ6.5	Φ6.5x4000mm	320

Sleeve

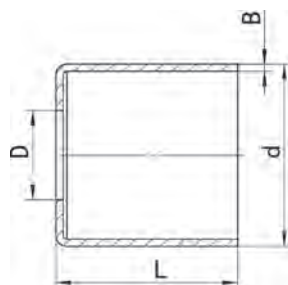

Model	D(mm)	d(mm)	L(mm)	B(mm)
HT-4	4.5	6.9	8	0.5
HT-6	6.2	8.9	12	0.5
HT-8	7.2	12.2	15	0.8



## Nylon Tube

### Feature

The material is PA6 (NPA) or PA11 (NPB), which has the characteristics of corrosion resistance, aging resistance, light weight, good toughness, easy bending, easy installation, smooth surface and low friction coefficient. The applicable temperature range is -40C~80°C.



Copper tube



Nylon tube



Aluminum tube

## Aluminum tube & brass tube

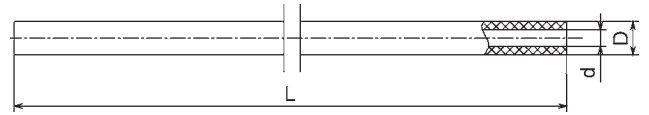

Model	Aluminum tube			Brass tube		
	Pressure MPa	3.0	2.7	2.7	16	10
Min radius mm	R20	R40	R40	R20	R30	R50
D	Φ4	Φ6	Φ8	Φ4	Φ6	Φ8
d	Φ2.5	Φ4	Φ6	Φ2.5	Φ4	Φ6
L	Customized					

### Order code

**NPA - 4 - 100(customized)**

NPA	Nylon tube PA6
NPB	Nylon tube PA11
AP	Aluminum tube
ACP	Copper plated tube
CP	Copper tube

100	100 meters
200	200 meters
4	Tube outer dia. Φ4
6	Tube outer dia. Φ6
8	Tube outer dia. Φ8
10	Tube outer dia. Φ10
12	Tube outer dia. Φ12

## Nylon Tube with Spring Cover

### Feature

It is composed of PA11 nylon tube, tube connector, double cone ferrule and spring protective sleeve. It is suitable for the lubrication system of the moving parts of the machine and the lubrication system that needs to be protected for cutting work. Temperature range is -40C~80°C.

### Specification

Model	NP-N4	NP-N6
Tube outer d1 (mm)	Φ4	Φ6
Pressure (MPa)	3.0	2.5
Min radius (MPa)	R30	R40
D	M8 x 1	M10 x 1
d2	Φ6	Φ8
L (mm)	18	18
F (mm)	Customized	

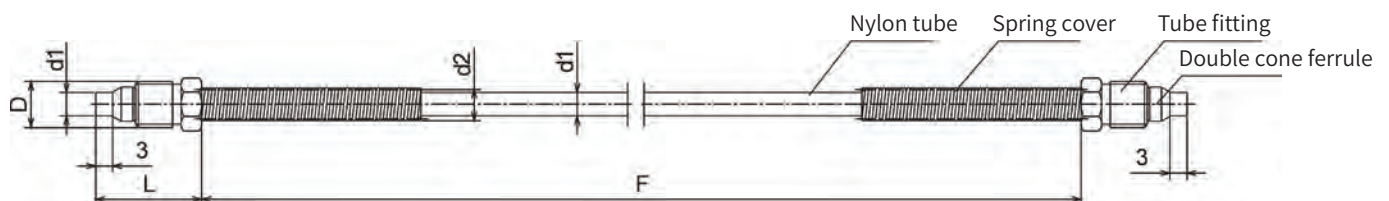

## Tube Clips

Order code

**PZ - 1 - 5 - 04**

1	Single side fixation
2	Double sided fixation

04~33	Tube dia. $\Phi 4$ to $\Phi 33$
1~5	1 to 5 tubes



item	Model	Fixing hole	Diameter	Tubes	Thickness	Width	Length	Screw hole
1	PZ-1104	1	$\Phi 4$	1	0.8	10	19	5.5
2	PZ-1204	1	$\Phi 4$	2	0.8	10	23	5.5
3	PZ-1304	1	$\Phi 4$	3	1.0	10	27	5.5
4	PZ-1404	1	$\Phi 4$	4	1.0	10	31	5.5
5	PZ-1106	1	$\Phi 6$	1	0.8	10	20	5.5
6	PZ-1206	1	$\Phi 6$	2	1.0	10	28	5.5
7	PZ-1306	1	$\Phi 6$	3	1.0	12	30	5.5
8	PZ-1108	1	$\Phi 8$	1	1.0	10	22	5.5
9	PZ1208	1	$\Phi 8$	2	1.0	12	30	5.5
10	PZ-1110	1	$\Phi 10$	1	1.0	10	26	5.5
11	PZ-12010	1	$\Phi 10$	2	1.2	12	40	5.5
12	PZ-1112	1	$\Phi 12$	1	1.2	12	30	7
13	PZ-1115	1	$\Phi 15$	1	1.6	20	42	7
14	PZ-2404	2	$\Phi 4$	4	1.2	8	42	7
15	PZ-2504	2	$\Phi 4$	5	1.2	8	46	7
16	PZ-2604	2	$\Phi 4$	6	1.2	8	50	7
17	PZ-2406	2	$\Phi 6$	4	1.2	8	50	7
18	PZ-2506	2	$\Phi 6$	5	1.2	18	50	7
19	PZ-1116	1	$\Phi 16$	1	1.2	17	39	7
20	PZ-1118	1	$\Phi 18$	1	1.2	20	47	6.5
21	PZ-1122	1	$\Phi 22$	1	1.2	20	50	7
22	PZ-1125	1	$\Phi 25$	1	1.2	20	55	6.5
23	PZ-1128	1	$\Phi 28$	1	1.5	18	55	7
24	PZ-1133	1	$\Phi 33$	1	1.5	23	68	7

## Tube Connector

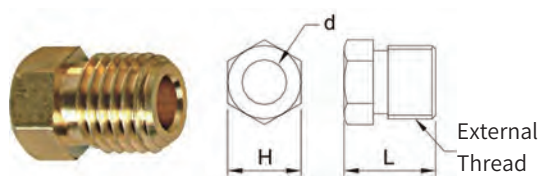

Model	Diameter	d	L	External Thread	H	Weight(g)
PA-4	Φ4	Φ4.1	12	M8xP1.0	8	3
PA-6	Φ6	Φ6.1	12.5	M10xP1.0	10	4
PA-8	Φ8	Φ8.1	14	M12xP1.0	14	9
PA-10	Φ10	Φ10.1	15	M12xP1.5	16	12

## Tube Sleeve

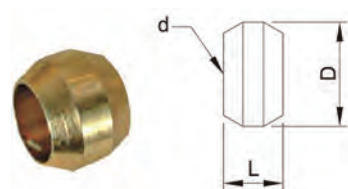

Model	Diameter	d	D	L	Weight(g)
PB-4	Φ4	Φ4.1	Φ6	4.6	0.3
PB-6	Φ6	Φ6.1	Φ8	4.6	0.6
PB-8	Φ8	Φ8.1	Φ11	7	2
PB-10	Φ10	Φ10.1	Φ13.5	8	3

## Straight Connector

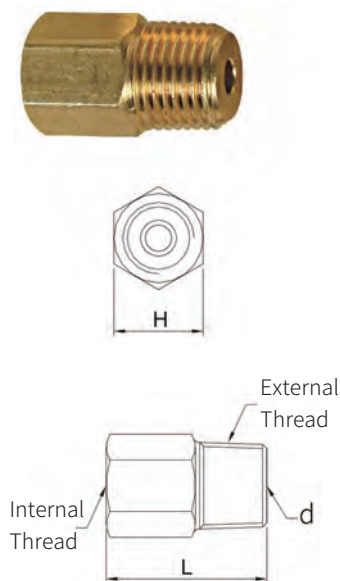

Model	Diameter	d	L	H	Internal Thread	External Thread	Weight(g)
PD-401	Φ4	Φ3	18	10	M8xP1.0	PT1/8	8
PD-402	Φ4	Φ3	18	14	M8xP1.0	PT1/4	17
PD-403	Φ4	Φ3	18	17	M8xP1.0	PT3/8	28
PD-601	Φ6	Φ4	18	12	M10xP1.0	PT1/8	8
PD-602	Φ6	Φ5	18	14	M10xP1.0	PT1/4	14
PD-603	Φ6	Φ5	18	17	M10xP1.0	PT3/8	24
PD-801	Φ8	Φ5	26	17	M14xP1.5	PT1/8	22
PD-802	Φ8	Φ6	26	17	M14xP1.5	PT1/4	26
PD-803	Φ8	Φ7	26	17	M14xP1.5	PT3/8	30
PD-1002	Φ10	Φ7	30	19	M14xP1.5	PT1/4	33
PD-1003	Φ10	Φ9	30	19	M14xP1.5	PT3/8	35
Standards							
Model	Diameter	d	L	H	Internal Thread	External Thread	Weight(g)
PD-404	Φ4	Φ1	18	10	M8xP1.0	M4xP0.5	5
PD-405	Φ4	Φ2	18	10	M8xP1.0	M5xP0.5	6
PD-406	Φ4	Φ2	18	10	M8xP1.0	M6xP0.75	6
PD-4061	Φ4	Φ2	18	14	M8xP1.0	M6xP1.0	6
PD-408	Φ4	Φ3	18	17	M8xP1.0	M8xP1.0	6
PD-410	Φ4	Φ3	18	12	M10xP1.0	M10xP1.0	6
PD-412	Φ4	Φ4	20	17	M10xP1.0	M12xP1.0	15
PD-608	Φ6	Φ3	18	14	M10xP1.0	M8xP1.0	8
PD-610	Φ6	Φ4	18	17	M10xP1.0	M10xP1.0	8
PD-612	Φ6	Φ4	20	17	M10xP1.0	M12xP1.0	12

## Elbow Connector

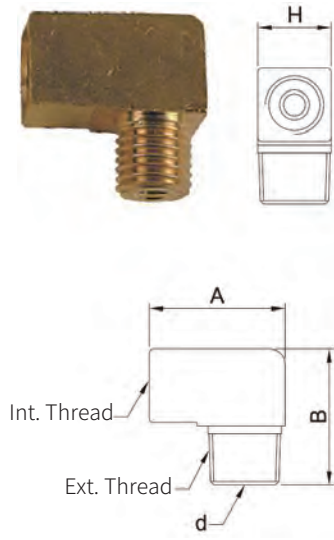

Model	Diameter	d	A	B	H	Int. Thread	Ext. Thread	Weight(g)
PH-401	Φ4	Φ4	18	18	10	M8xP1.0	PT1/8	13
PH-402	Φ4	Φ5	20	21	14	M8xP1.0	PT1/4	32
PH-403	Φ6	Φ4	20	20	12	M10xP1.0	PT1/8	20
PH-601	Φ6	Φ5	20	21	14	M10xP1.0	PT1/4	29
PH-602	Φ8	Φ4	26	29	17	M14xP1.5	PT1/8	52
PH-603	Φ8	Φ6	26	29	17	M14xP1.5	PT1/4	56
PH-801	Φ8	Φ8	26	29	17	M14xP1.5	PT3/8	59
PH-802	Φ10	Φ7	29	31	19	M16xP1.5	PT1/4	70
PH-803	Φ10	Φ8	29	31	19	M16xP1.5	PT3/8	76

### Standards

Model	Diameter	d	A	B	H	Int. Thread	Ext. Thread	Weight(g)
PH-404	Φ4	Φ1	18	18	10	M8xP1.0	M4xP0.5	11
PH-405	Φ4	Φ1	18	18	10	M8xP1.0	M5xP0.5	11
PH-406	Φ4	Φ2	18	18	10	M8xP1.0	M6xP0.75	13
PH-4061	Φ4	Φ2	18	18	10	M8xP1.0	M6xP1.0	12
PH-408	Φ4	Φ3	18	18	10	M8xP1.0	M8xP1.0	13
PH-410	Φ4	Φ2	20	20	12	M8xP1.0	M10xP1.0	24
PH-608	Φ6	Φ3	20	20	12	M10xP1.0	M8xP1.0	20
PH-610	Φ6	Φ4	20	20	12	M10xP1.0	M10xP1.0	22

## One-way Straight Connector

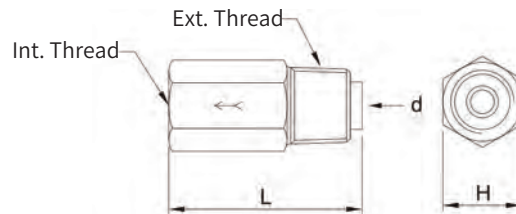

Model	Diameter	d	L	H	Int. Thread	Ext. Thread	Weight(g)
PD-4011	Φ4	Φ2.2	24.5	10	M8xP1.0	PT1/8	11
PD-6011	Φ4	Φ2.2	25.5	12	M10xP1.0	PT1/8	14

## Reverse Straight Connector

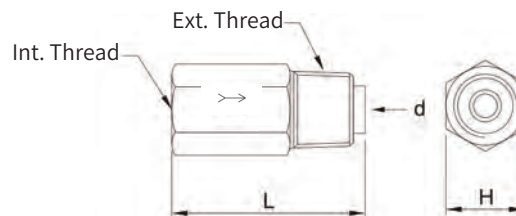

Model	Diameter	d	L	H	Int. Thread	Ext. Thread	Weight(g)
PD-4012	Φ4	Φ2.2	24.5	10	M8xP1.0	PT1/8	11
PD-6012	Φ4	Φ2.2	25.5	12	M10xP1.0	PT1/8	14

## Closure Plug

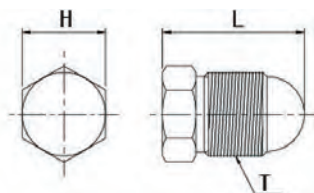

Model	L	T	H	Weight(g)
PG-04	15	M8x1.0	8	5.4
PG-06	18	M10x1.0	10	8.8

## One-way Elbow Connector

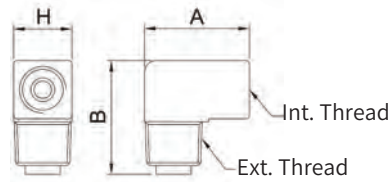

Model	Diameter	d	A	B	H	Int. thread	Ext. thread	Weight(g)
PH-4011	Φ4	Φ2.2	18	19.5	10	M8xP1.0	PT1/8	11
PH-6011	Φ6	Φ2.2	20	21.5	12	M10xP1.0	PT1/8	14

## Reverse Elbow Connector

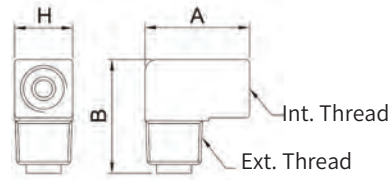

Model	Diameter	d	A	B	H	Int. thread	Ext. thread	Weight(g)
PH-4012	Φ4	Φ2.2	18	19.5	10	M8xP1.0	PT1/8	11
PH-6012	Φ6	Φ2.2	20	21.5	12	M10xP1.0	PT1/8	14

## Tube Lining

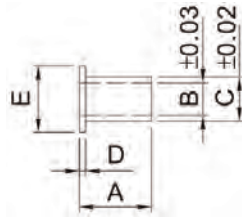

Model	Diameter	A	B	C	D	E
PI-3	Φ3	10	Φ2	Φ3.0	0.5	Φ4.5
PI-4	Φ4	10	Φ1.6	Φ2.0	0.5	Φ4
PI-425	Φ4	10	Φ1.7	Φ2.5	0.5	Φ4
PI-6	Φ6	13	Φ3.4	Φ4.0	0.6	Φ6
PI-8	Φ8	13	Φ4.9	Φ6.0	0.6	Φ8
PI-10	Φ10	15	Φ5.9	Φ7.9	0.6	Φ10

## Ferrule Nut

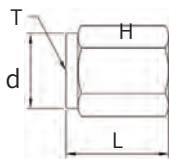

Model	Diameter	d	L	T	H	Weight(g)
PR-4	Φ4	Φ4.05	13	M8xP1.0	10	3
PR-6	Φ6	Φ6.05	13.5	M10xP1.0	12	5

## Plane Elbow Connector

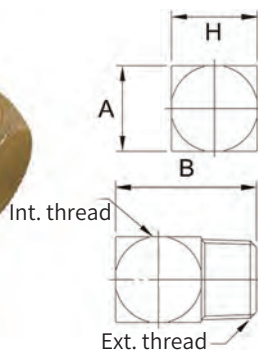

Model	A	B	Int. thread	Ext. thread	H	Weight(g)
PF-4061	12	20	M8xP1.0	M6xP1.0	12	14
PF-408	12.7	21	M8xP1.0	M8xP1.0	12.7	12
PF-410	12.7	21	M8xP1.0	M10xP1.0	12.7	13
PF-401	12.7	21	M8xP1.0	PT1/8	12.7	13
PF-610	12	20	M10xP1.0	M10xP1.0	12	10
PF-601	12.7	21	M10xP1.0	PT1/8	12.7	13
PF-101	12	20	PT1/8	PT1/8	12	10

## Double Female Connector

Adapter A

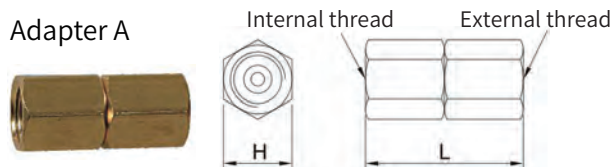

Model	Diameter	H	L	Int. thread	Weight(g)
TM-8	Φ4	10	23	M8xP1.0	17
TM-10	Φ6	12	25	M10xP1.0	12

Adapter B



Model	Diameter	H	L	T1	T2	Weight(g)
TN-801	Φ4	12	23	M8xP1.0	PT1/8	16
TN810	Φ4	12	23	M8xP1.0	M10xP1.0	14
TN-1001	Φ6	12	23	M10xP1.0	PT1/8	12

## Double Male Connector

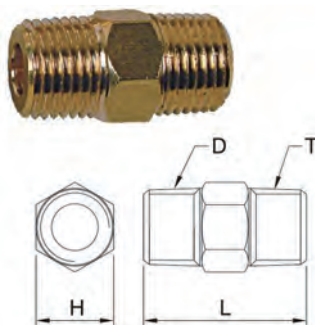

Molde	Diameter	Material	H	L	Weight(g)
TD-101	PT1/8xPT1/8	Brass	10	21	8
TD-202	PT1/4xPT1/4	Brass	14	25	10
TD-404	PT1/2xPT1/2	Brass	23	40	68
TD-1001	M10xPT1/8	Brass	10	20	8.5
TD-1010	M10xM10	Brass	10	20	7.5
TD-0808	M8xM8	Brass	10	22	6.6
TD-0801	M8xPT1/8	Brass	10	22	8.4

## Active Elbow Connector

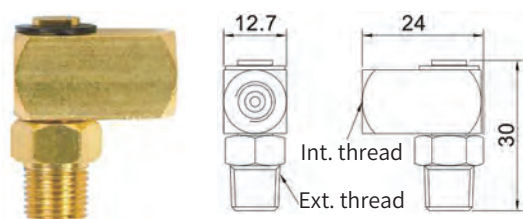

Model	Int. thread	Ext. thread	Weight(g)
FS-408	M8xP1.0	M8xP1.0	38
FS-410	M8xP1.0	M10xP1.0	38
FS-401	M8xP1.0	PT1/8	38
FS-608	M10xP1.0	M8xP1.0	38
FS-610	M10xP1.0	M10xP1.0	38
FS-601	M10xP1.0	PT1/8	38

## Universal Connector

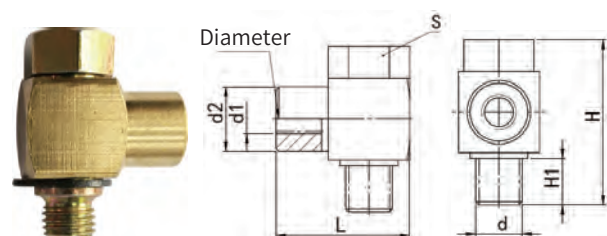

Model	Diameter	d	d1	d2	L	H	H1	S
PS-406	Φ4	M6x1.0	M8x1.0	Φ11	23	29.5	6	12
PS-408	Φ4	M8x1.0	M8x1.0	Φ11	23	29.5	6	12
PS-410	Φ4	M10x1.0	M8x1.0	Φ11	23	29.5	6	12
PS-606	Φ6	M6x1.0	M10x1.0	Φ13	27	31	8	12
PS-608	Φ6	M8x1.0	M10x1.0	Φ13	27	31	8	12
PS-610	Φ6	M10x1.0	M10x1.0	Φ13	27	31	8	12



## Oil brush

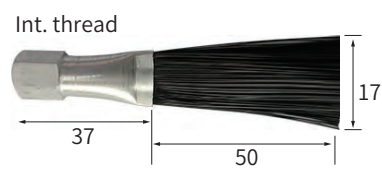

OM

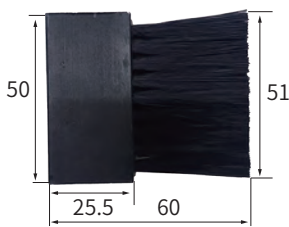

OML

Model	Internal thread	Weight (g)
OM408	M8xP1.0	11
OM610	M10xP1.0	15
OM601	PT1/8	17
OML601	PT1/8	25
OML401	PT1/8	27

## Fixed Double Connector

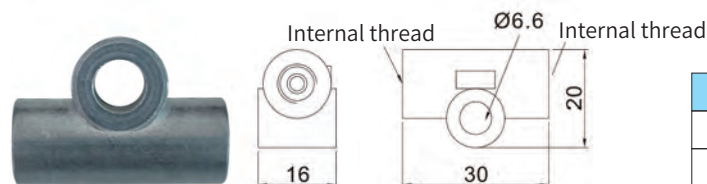

Model	Int. thread	Int. thread	Weight(g)
JD-4	Φ4	M8xP1.0	22
JD-6	Φ6	M10xP1.0	25

## Three-way Connector

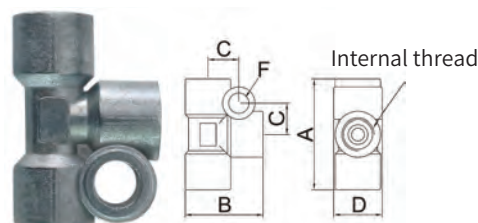

Model	Diameter	A	B	C	D	F	Int. thread	Weight(g)
PKD-4	Φ4	29	19.5	8.5	12	Φ6.3	M8xP1.0	16
PKD-6	Φ6	34	24	9.5	15		M10xP1.0	32
PKD-8	Φ8	42	31	14.5	19	Φ6.8	M14xP1.5	64
PKD-10	Φ10	51	37	16	24		M16xP1.5	89

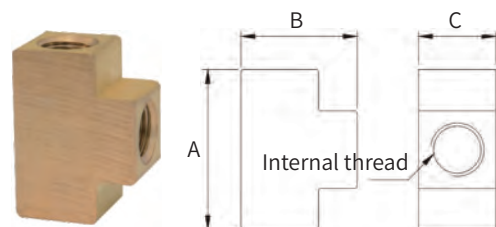

Model	A(mm)	A(mm)	B(mm)	C(mm)	Weight(g)
PKDB-1	PT1/8	29.0	21	14	34
PKDB-2	PT1/4	28.5	23	18	47
PKDB-3	PT3/8	40.0	30	21	86

## Four-way Connector

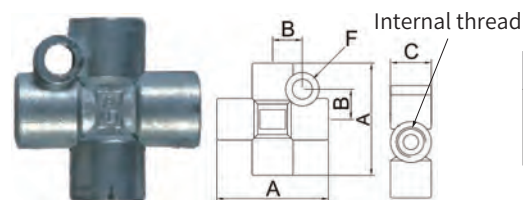

Model	Diameter	A	B	C	D	Int. thread	Weight(g)
PJD-4	Φ4	30	8	11	Φ5.3	M8xP1.0	23
PJD-6	Φ6	34	9	15.5	Φ5.8	M10xP1.0	33
PJD-8	Φ8	41.5	12	22	Φ6.8	M14xP1.0	94

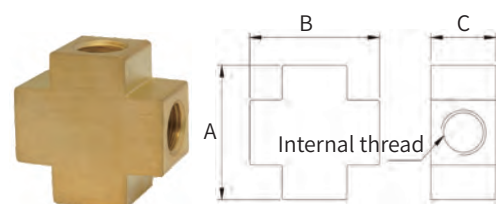

Model	A(mm)	A(mm)	B(mm)	C(mm)	Weight(g)
PJDB-1	PT1/8	28.5	28.5	14	38
PJDB-2	PT1/4	30.5	30.5	18	58
PJDB-3	PT3/8	40.0	40.0	21	105

## Quick Straight Connector

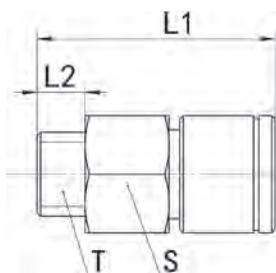

Model	Diameter	T	S	L1	L2
APC403	Φ4	M3x0.75	9	21	5
APC404	Φ4	M4x0.75	9	21	5
APC405	Φ4	M5x0.8	9	21	5
APC406	Φ4	M6x0.75	9	21	5
APC4061	Φ4	M6x1.0	9	21	5
APC408	Φ4	M8x1.0	10	19	6
APC410	Φ4	M10x1.0	12	19	7
APC401	Φ4	PT1/8	12	19	7
APC603	Φ6	M3x0.75	12	24	5
APC604	Φ6	M4x0.75	12	24	5
APC605	Φ6	M5x0.8	12	24	7
APC606	Φ6	M6x0.75	12	24	7
APC6061	Φ6	M6x1.0	12	24	7
APC608	Φ6	M8x1.0	12	24	7
APC610	Φ6	M10x1.0	12	24	7
APC601	Φ6	PT1/8	12	24	7

## Quick Elbow Connector

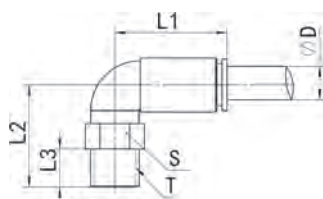

Model	Diameter	T	S	L1	L2	L3	D
APLV403	Φ4	M3x0.75	10	20	17	6	9
APLV404	Φ4	M4x0.75	10	20	17	6	9
APLV405	Φ4	M5x0.8	10	20	17	6	9
APLV406	Φ4	M6x0.75	10	20	17	6	9
APLV4061	Φ4	M6x1.0	10	20	17	7	9
APLV408	Φ4	M8x1.0	10	20	19	7	9
APLV410	Φ4	M10x1.0	12	20	19	7	9
APLV401	Φ4	PT1/8	12	20	18	7	9
APLV603	Φ6	M3x0.75	10	24	18	6	12
APLV604	Φ6	M4x0.75	10	24	18	6	12
APLV605	Φ6	M5x0.8	10	24	20	6	12
APLV606	Φ6	M6x0.75	10	24	20	6	12
APLV6061	Φ6	M6x1.0	10	24	20	7	12
APLV608	Φ6	M8x1.0	10	24	20	7	12
APLV610	Φ6	M10x1.0	12	24	20	7	12
APLV601	Φ6	PT1/8	12	24	20	7	12

## Quick Double Connector

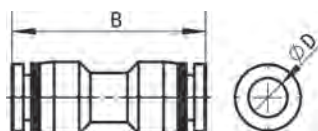

Model	D	B
AJM-4	Φ4	45
AJM-6	Φ6	49
AJM-8	Φ8	57

## Quick Rotary Elbow

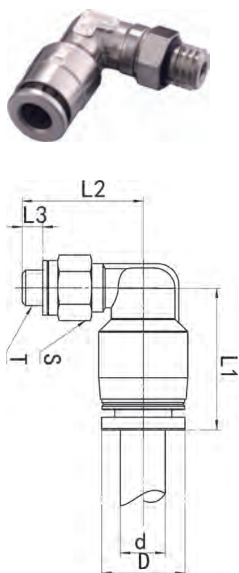

Model	Diameter	T	S	L1	L2	L3	D
AFS403	Φ4	M3x0.75	10	20	17	6	9
AFS404	Φ4	M4x0.75	10	20	17	6	9
AFS405	Φ4	M5x0.8	10	20	17	6	9
AFS406	Φ4	M6x0.75	10	20	17	6	9
AFS4061	Φ4	M6x1.0	10	20	17	7	9
AFS408	Φ4	M8x1.0	10	20	19	7	9
AFS410	Φ4	M10x1.0	12	20	19	7	9
AFS401	Φ4	PT1/8	12	20	18	7	9
AFS603	Φ6	M3x0.75	10	24	18	6	12
AFS604	Φ6	M4x0.75	10	24	18	6	12
AFS605	Φ6	M5x0.8	10	24	20	6	12
AFS606	Φ6	M6x0.75	10	24	20	6	12
AFS6061	Φ6	M6x1.0	10	24	20	7	12
AFS608	Φ6	M8x1.0	10	24	20	7	12
AFS610	Φ6	M10x1.0	12	24	20	7	12
AFS601	Φ6	PT1/8	12	24	20	7	12

## Quick Articulated Connector



Model	Diameter	T	S	L1	L2	L3	D
APS403	Φ4	M3x0.75	10	20	17	6	9
APS404	Φ4	M4x0.75	10	20	17	6	9
APS405	Φ4	M5x0.8	10	20	17	6	9
APS406	Φ4	M6x0.75	10	20	17	6	9
APS4061	Φ4	M6x1.0	10	20	17	7	9
APS408	Φ4	M8x1.0	10	20	19	7	9
APS410	Φ4	M10x1.0	12	20	19	7	9
APS401	Φ4	PT1/8	12	20	18	7	9
APS601	Φ6	M10x1	10	24	18	6	12
APS605	Φ6	M5x0.8	10	24	18	6	12
APS606	Φ6	M6x0.75	10	24	20	6	12
APS6061	Φ6	M6x1.0	10	24	20	6	12
APS608	Φ6	M8x1.0	10	24	20	7	12
APS610	Φ6	M10x1.0	10	24	20	7	12
APS601	Φ6	PT1/8	12	24	20	7	12
APS810	Φ8	M10x1.0	14	26	22	7	14
APS801	Φ8	PT1/8	14	26	22	7	14

## Quick 3-way Connector

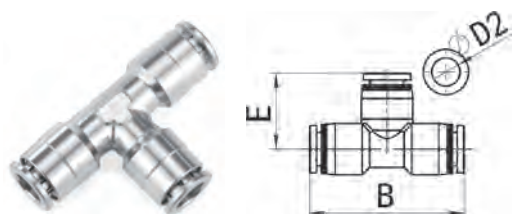

Model	Diameter	E	B
APKD-4	Φ4	19	45
APKD-6	Φ6	22	49
APKD-8	Φ8	27	57

## Quick Check Valve

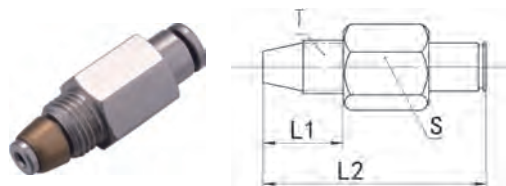

Model	Diameter	T	S	L1	L2
APV4	Φ4	M10x1.0	10	10	30
APV6	Φ6	M10x1.0	10	10	30
APV8	Φ8	M10x1.0	12	10	30
APV10	Φ10	M10x1.0	12	10	30

## Quick Seal Straight Connector

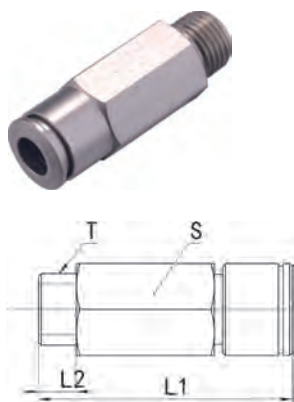

Model	Diameter	T	S	L1	L2
ATPC403	Φ4	M3x0.75	9	24	6
ATPC404	Φ4	M4x0.75	9	24	6
ATPC405	Φ4	M5x0.8	9	24	6
ATPC406	Φ4	M6x0.75	9	24	6
ATPC4061	Φ4	M6x1.0	9	24	6
ATPC408	Φ4	M8x1.0	10	24	6
ATPC410	Φ4	M10x1.0	12	24	7
ATPC401	Φ4	PT1/8	12	24	7
ATPC605	Φ6	M5x0.8	12	24	7
ATPC606	Φ6	M6x0.75	12	24	7
ATPC6061	Φ6	M6x1.0	12	27	7
ATPC608	Φ6	M8x1.0	12	27	7
ATPC610	Φ6	M10x1.0	12	27	7
ATPC601	Φ6	PT1/8	12	27	7
ATPC810	Φ8	M10x1.0	14	27	7
ATPC 801	Φ8	PT1/8	14	27	7

## Quick Seal Rotary Elbow

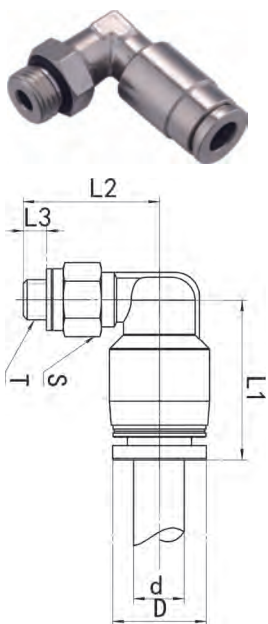

Model	Diameter	T	S	L1	L2	L3	D
ATFS403	Φ4	M3x0.75	10	23	17	6	9
ATFS404	Φ4	M4x0.75	10	23	17	6	9
ATFS405	Φ4	M5x0.8	10	23	17	6	9
ATFS406	Φ4	M6x0.75	10	23	17	6	9
ATFS4061	Φ4	M6x1.0	10	23	17	7	9
ATFS408	Φ4	M8x1.0	10	23	19	7	9
ATFS410	Φ4	M10x1.0	12	23	19	7	9
ATFS401	Φ4	PT1/8	12	23	18	7	9
ATFS603	Φ6	M3x0.75	10	27	18	6	12
ATFS604	Φ6	M4x0.75	10	27	18	6	12
ATFS605	Φ6	M5x0.8	10	27	20	6	12
ATFS606	Φ6	M6x0.75	10	27	20	6	12
ATFS6061	Φ6	M6x1.0	10	27	20	7	12
ATFS608	Φ6	M8x1.0	10	27	20	7	12
ATFS610	Φ6	M10x1.0	12	27	20	7	12
ATFS601	Φ6	PT1/8	12	27	20	7	12

## Extended Quick Straight Connector

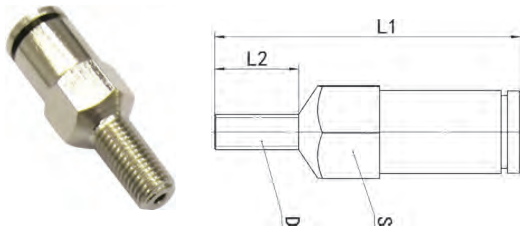

Model	Diameter	D	L1	L2	S
LKPC-406	Φ4	M6x0.75	26	12	10

## Extended Quick Activity Connector

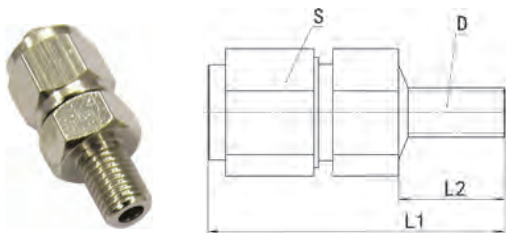

Model	Diameter	D	L1	L2	S
LPCS-406	Φ4	M6x0.75	22	8	10

## Extended Quick Activity Wlbow

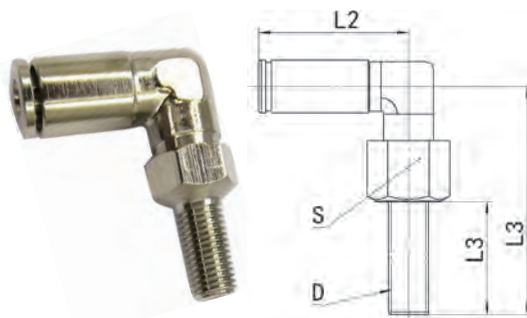

Model	Diameter	D	L1	L2	L3	S
LAFS-406	Φ4	M6x0.75	25	23	12	10
LAFS-4061	Φ4	M6x1.0	25	23	12	10

## Extended Quick Articulated Elbow

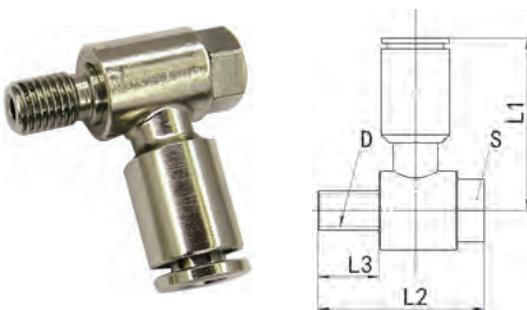

Model	Diameter	D	L1	L2	L3	S
LAPS-406	Φ4	M6x0.75	23	26	6.5	10
LAPS-4061	Φ4	M6x1.0	24	26	8	10
LAPS-606	Φ6	M6x0.75	23	27	6.5	10
LAPS-6061	Φ6	M6x1.0	25	27	8	10

## Through Plate Straight Connector

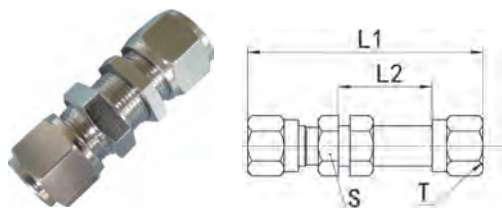

Model	Diameter	T	S	L1	L2
APM-4	Φ4	M10x1.0	10	30	10
APM-6	Φ6	M10x1.0	10	30	10
APM-8	Φ8	M10x1.0	12	30	10
APM-10	Φ10	M10x1.0	12	30	10

## Quick Tightening Connector

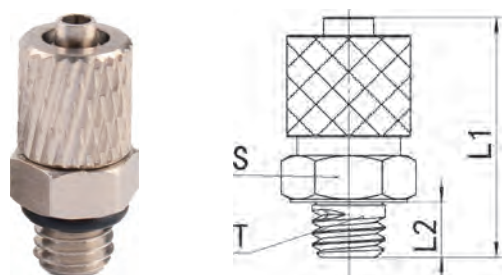

Model	Diameter	T	S	L1	L2
KPC-403	Φ4	M3x0.75	7	15.2	3
KPC-405	Φ4	M5x0.75	7	15.9	4
KPC-406	Φ4	M6x0.75	8	15.9	4.3
KPC-401	Φ6	PT1/8	10	15.9	5
KPC-603	Φ6	M3x0.75	8	17.4	3.5
KPC-605	Φ6	M5x0.75	8	17.9	4
KPC-606	Φ6	M6x0.75	8	17.9	4.3
KPC-601	Φ6	PT1/8	10	17.9	5

## Quick Tightening Elbow

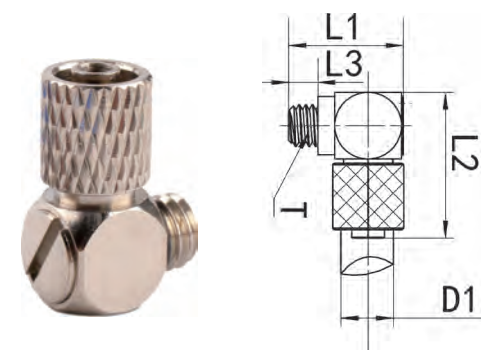

Model	Diameter	T	D1	L1	L2	L3
KPL-403	Φ4	M3x0.75	9	11.5	16.5	3
KPL-405	Φ4	M5x0.75	9	12.1	16.5	3.5
KPL-406	Φ4	M6x0.75	9	12.6	16.6	3.7
KPL-401	Φ4	PT1/8	11	13	17	5
KPL-603	Φ6	M3x0.75	11	11.5	17.8	3
KPL-605	Φ6	M5x0.75	11	12.1	17.8	3.5
KPL-606	Φ6	M6x0.75	11	12.3	17.8	3.7
KPL-601	Φ6	PT1/8	11	13	18	5

## Detachable Straight Connector

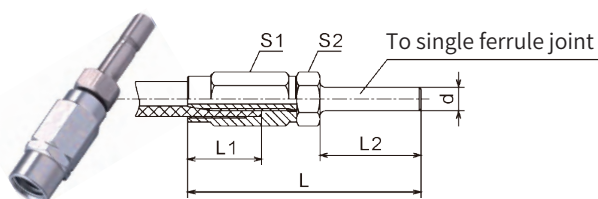

Model	Diameter	L1	L2	L	S1	S2	Material
KD4	Φ4	19	20	53	11	12	Carbon steel
KDS6	Φ6	19	26	60	10	12	Stainless steel
KD6	Φ6	19	30	65	10	12	Carbon steel
KD8	Φ8	19	26	60	12	12	Carbon steel
KD10	Φ10	19	30	63	14	12	Carbon steel

## Detachable Straight Elbow

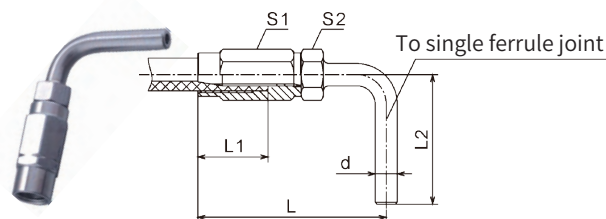

Model	Diameter	L1	L2	L	S1	S2	Material
KH6	Φ6	19	35	54	10	12	Carbon steel
KHS6	Φ6	19	35	56	10	12	Stainless steel
KH8	Φ8	19	48	54	12	12	Carbon steel



## Sleeve Straight Connector (GB/ T3733.1-1983)

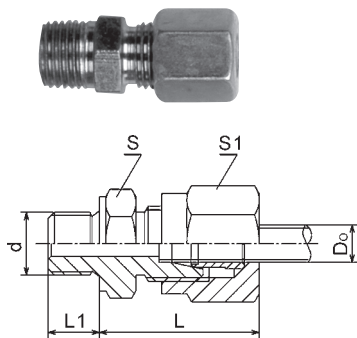

Model	Do	L1	L≈	d	S	S1
DCN-410	Φ4	8	23	M10x1	15	15
DCN-610	Φ6	8	27	M10x1	15	16
DCN-812	Φ8	12	30	M12x1.5	16	18
DCN-1014	Φ10	12	34	M14x1.5	18	21
DCN-1216	Φ12	12	34	M16x1.5	21	24
DCN-1418	Φ14	12	34	M18x1.5	24	24
DCN-1622	Φ16	14	36	M22x1.5	2	27
DCN-1822	Φ18	14	36	M22x1.5	27	30
DCN-2027	Φ20	16	39	M27x2	34	34
DCN-2227	Φ22	16	43	M27x2	34	36

## Parallel Thread Straight Connector

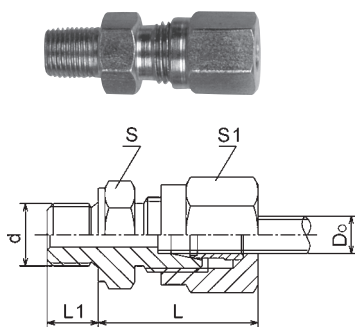

Model	Tube OD	L1	L≈	d	S	S1
SK-G401	Φ4	8	25	G1/8	14	12
SK-G601	Φ6	8	25	G1/8	14	14
SK-G602	Φ6	10	29	G1/4	21	14
SK-G801	Φ8	8	29	G1/8	14	17
SK-G802	Φ8	10	34	G1/4	21	17
SK-G803	Φ8	12	31	G3/8	21	17
SK-G1001	Φ10	10	34	G1/8	21	21
SK-G1002	Φ10	10	34	G1/4	21	21
SK-G1003	Φ10	12	34	G3/8	21	21
SK-G1203	Φ12	12	34	G3/8	21	22

## Taper Thread Straight Connector

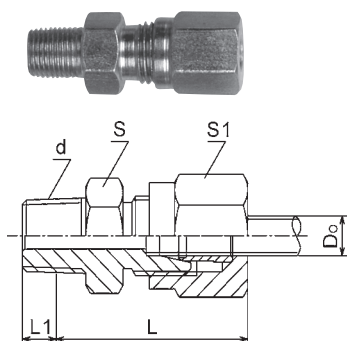

Model	Tube OD	L1	L≈	d	S	S1
SK-PD601A	Φ6	4.0	27	R1/8	11	12
SK-PD601B	Φ6	4.1	27	NPT1/8	11	12
SK-PD601C	Φ6	4.0	35	R1/8	14	14
SK-PD602	Φ6	6.0	36	R1/4	14	14
SK-PD603	Φ6	6.4	37	R3/8	17	14
SK-PD801A	Φ8	4.0	27	R1/8	17	14
SK-PD801B	Φ8	4.1	27	NPT1/8	13	14
SK-PD801C	Φ8	4.0	38	R1/8	13	17
SK-PD802	Φ8	6.0	36	R1/4	17	17
SK-PD803	Φ8	6.4	36	R3/8	14	17
SK-PD1001A	Φ10	4.1	36	R1/8	17	21
SK-PD1002	Φ10	6.0	36	R1/4	14	21
SK-PD1003C	Φ10	6.4	41	R3/8	17	21
SK-PD1003B	Φ10	6.1	41	NPT3/8	17	21
SK-PD1202C	Φ12	6.0	40	R1/4	18	22
SK-PD1203C	Φ12	6.4	44	R3/8	21	22

## Sleeve Elbow (GB/T3738.1-1983)

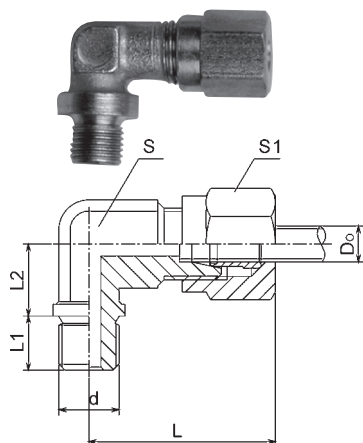

Model	Do	L1	L2	L $\approx$	d	S	S1
HCN-610	Φ6	8	13	31	M10X1	10	16
HCN-812	Φ8	12	17.5	35	M12X1.5	11	18
HCN-1014	Φ10	12	18.5	39	M14X1.5	15	21
HCN-1216	Φ12	12	20	40	M16X1.5	15	24
HCN-1418	Φ14	12	21	41	M18X1.5	18	24
HCN-1618	Φ16	14	23	44	M18X1.5	21	27
HCN-1822	Φ18	14	23	45	M22X1.5	21	30
HCN-2027	Φ20	16	25.5	49	M27X2.5	24	34

## Sleeve Taper Thread Elbow

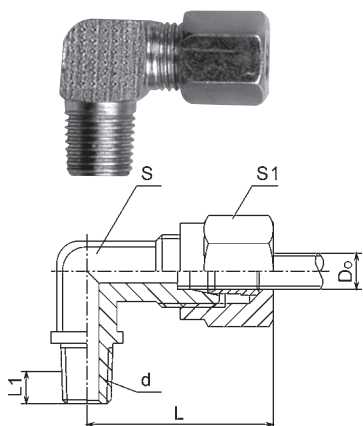

Model	Do	L1	L $\approx$	d	S	S1
LK-HR601A	Φ6	4.0	28	R1/8	11	12
LK-HR601B	Φ6	4.1	28	NPT1/8	11	12
LK-HR801A	Φ8	4.0	28	R1/8	13	14
LK-HR801B	Φ8	4.1	28	NPT1/8	13	14
LK-HR601C	Φ6	4.0	26	R1/8	13	14
LK-HR801C	Φ8	4.0	38	R1/8	16	17
LK-HR801B	Φ8	4.1	30	NPT1/8	14	17
LK-HR1001A	Φ10	4.0	39	R1/8	14	21
LK-HR1202B	Φ12	6.0	38	NPT1/4	18	22

## Butt Straight Connector (GB/T3737-1983)

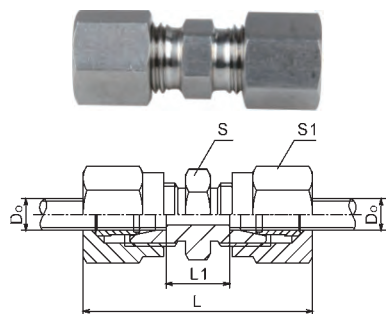

Model	Do	L1	L $\approx$	S	S1
TTD-4	Φ4	25	56	13	15
TTD-6	Φ6	30.4	65	13	16
TTD-8	Φ8	36	72	15	18
TTD-10	Φ10	38	78	18	21

## Transition Connector

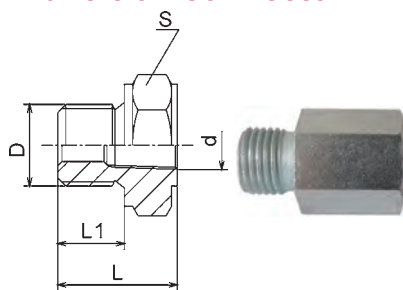

Model	L1	L	D	d	S1
SC-D0201	10	21	G1/4	NPT1/8	17
SC-D0210	10	21	G1/4	M10x1	17
SC-D1001	10	23	M10x1	NPT1/8	17
SC-D0201	10	21	G1/4	Rc1/8	17
SC-D0202	10	26	G1/4	NPT1/4	19

## Turcite-B Sheet

### Dixon Slide Rail Wear Plate

1. Eliminate crawling: move quickly and accurately, and reduce power loss.
2. Eliminate deformation: Eliminate lotus leaf edge and load shear deformation to reduce costs.
3. Reduce vibration: reduce noise and vibration during work.
4. Oil-free lubrication: When the machine lubrication system fails, the guide rail will not be damaged.
5. The friction coefficient is stable: when the speed load and temperature change, the friction system is constant and does not need to be adjusted.
6. Long service life: prolong the maintenance cycle of machine tools.
7. Convenient installation: The installation process is simple.
8. Wide range of uses: horizontal, vertical or rotating slides.

### Specification

Characteristic	ASTM	Unit	Value
Proportion	D792	-	3.16
Water absorption	D570	%	0
Coefficient of expansion	D696	(MM/°C)	$(8.8 \times 10^{-10})$
Hardness	D1706	Shore D	61-63
Tensile strength	D4894	psi(Mpa)	3100(21.4)
Elongation (length direction)	D4894	%	200
Maximum PV (continuous operation)	—	psi × ft./min.(Mpa × m/s)	10000(0.35)
Limit PV (continuous operation after pasting)	—	psi × ft./min.(Mpa × m/s)	25000(0.88)
Width x Thickness	305x0.8mm    305x1.2mm    305x1.5 mm    305x2.0 mm    305x2.5 mm    305x4.0 mm		

Note: The above data are obtained under our experimental conditions and are for reference only.



## Nanpao Resin 906



1. Fast bonding of guide rail wear-resistant sheets, metal pottery, stone, glass and other materials.
2. Strong adhesive, good adhesion, strong after hardening and impact resistance.
3. The use time is about 1~1.5 hours, the operability is convenient, and it is suitable for large-scale bonding.

Instructions:

1. It is divided into two parts: main agent and hardener. When using, take the same volume and mix well and stir evenly.
2. Treat the surface of the material to be bonded, remove grease, stains and moisture.
3. After smearing the mixture of this agent on the adhesive surface, gently fit the two contact surfaces, and the pressure can be removed after 1~1.5 hours.

Precautions:

1. Once the two liquids are mixed, they should be used within 1 to 1.5 hours, otherwise they cannot be used after hardening.
2. Silicon rubber, PVC, PE, PS, etc. are not suitable for this product.



## Adhesive E250



1. For the development of the machine tool guide rail plastic sticking scheme, it has high bonding strength to the machine tool guide rail soft belt, cast iron, copper, aluminum, steel, stainless steel, plastic, rubber, stone, wood and glass.
2. Adhesive is a white liquid (white cover), hardener is a brown liquid (blue cover).
3. It can be used in the temperature range of -30°C~+70°C.
4. Two liquids are mixed and used according to the volume ratio A:B=1:1.2, the ratio can be adjusted, such as winter construction, the ratio of hardener can be increased.
5. Moisture-proof and light-proof preservation, effective storage period of 1 year.
6. Once the two solutions are mixed, the coating must be completed within 45 minutes of the initial curing time, and the complete curing time is 24 hours.

## Blued & Red Touch Paste



It is used for grinding precision inspection of machine tool guide rail soft belt scraping, gears, molds, bearings, bearing bushes, valves and other processed parts. It has the advantages of no delamination, good tinting strength, no particles, good adhesion, no lead compounds, and high safety.

Instructions for use:

1. Clean and dry the required processing parts.
2. Apply a layer evenly on the surface of mechanical parts.
3. Install the components in their normal positions and start.
4. Distinct blue glossy dots indicate mismatched assembly.
5. Correct the installation position of the components.

**Felt Gear**

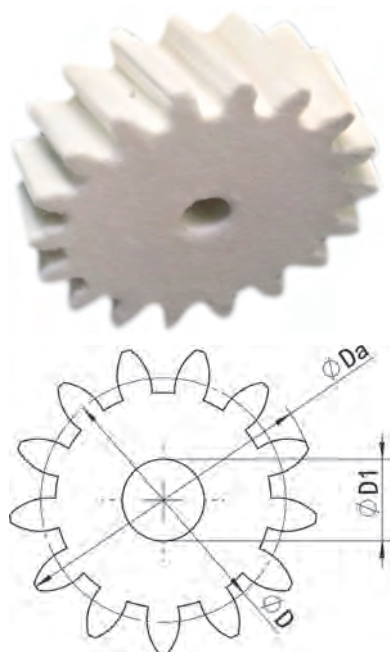

Model	Modulus	Teeth	D	D1	Da	Thickness
FG-1526S12	1.5	26	19	12	42	20
FG-1525L12	1.5	25L	39.7	12	42.7	20
FG-1525R12	1.5	25R	39.7	12	42.7	20
FG-2019S12	2.0	19	38	12	42.0	25
FG-2018S12	2.0	18L	38.2	12	42.2	25
FG-2018R12	2.0	18R	38.2	12	42.2	25
FG-3019S12	3.0	19	57	12	63.0	30
FG-3018L12	3.0	18L	57.5	12	63.5	30
FG-3018R12	3.0	18R	57.5	12	63.5	30
FG-4019S12	4.0	18	76	12	84	40
FG-4018L12	4.0	17L	72.4	12	80.4	40
FG-4018R12	4.0	17R	72.4	12	80.4	40
FG-5019S12	5.0	17	85	20	95	50
FG-5018L12	5.0	17L	90.5	20	100.5	50
FG-5018R12	5.0	17R	90.5	20	100.5	50
FG-6019S12	6.0	17	102	20	114.0	50
FG-6018L12	6.0	17L	108.5	20	120.5	50
FG-6018R12	6.0	17R	108.5	20	120.5	50

**Order code**

<b>FG</b>	<b>15</b>	<b>26</b>	<b>S</b>	<b>12</b>	<b>A</b>	<b>20</b>
	<b>Modulus</b>	<b>Number of teeth</b>	<b>Tooth shape</b>	<b>Internal diameter</b>	<b>Rotation angle</b>	<b>Gear thickness</b>
	15 = 1.5 modulus	17= 17 teeth	S = spur gear	12= $\Phi$ 12	A = 19°	12 = 12mm
	20 = 2.0 modulus	...	L = left-hand tooth		B = 31°	...
		26 = 26 teeth	R = right-hand tooth		C = 42°	50 = 50mm

**Scraping Plate**

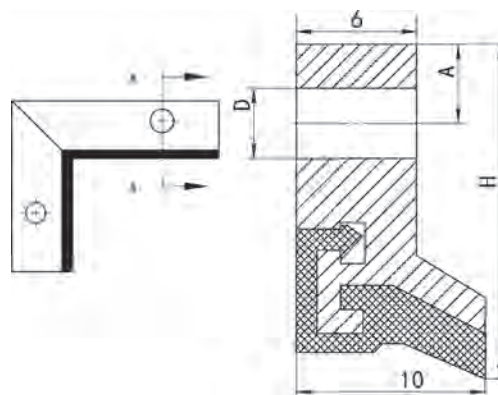
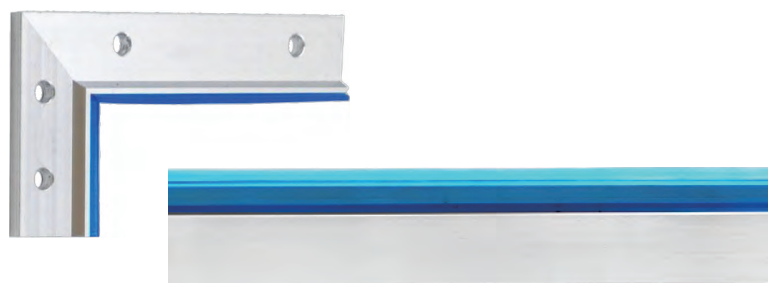

Model	S16	S18	S20	S25	S30	S35	S40	S50	S70
H	16	18	20	25	30	35	40	50	70
A	5	6	7	8	12	14	16	21	31
D	5.2	6.2	6.2	6.2	6.2	6.2-8.2	6.2-8.2	6.2-10.2	6.2-10.2

Its standard length is 1 meter, the length can be customized, and the shape can be customized.