

7-77-05-09

KA2262

LINEAR INTEGRATED CIRCUIT

FM STEREO MULTIPLEX DECODER
FOR CAR STEREO

KA2262 is a multiplex IC for FM car stereo, and it has the following 2 functions through its utilization of the IF meter output voltage, etc.

1. Stereo noise control (SNC) under which the noise particular on the FM stereo unit in the weak electric field is reduced smoothly.
2. High-cut control (HCC) under which the high frequency is smoothly attenuated.

In addition, KA2262 can be, due to its low distortion factor, an IC for multiplex stereo demodulator which is appropriate for the car component stereo unit.

FUNCTIONS

- Stereo noise control (SNC Terminal).
- High-cut control (HCC Terminal).
- Stereo/Monaural automatic conversion.
- Stoppage of VCO oscillation.
- With separation control terminal.

FEATURES

- Low distortion (0.05%: Typ).
- Good ripple rejection (35dB: Typ).
- Wide operating supply voltage range (6.5V ~ 14V).
- The space factor is advantageous because of the ZIP.
- High channel separation (50dB: Typ).

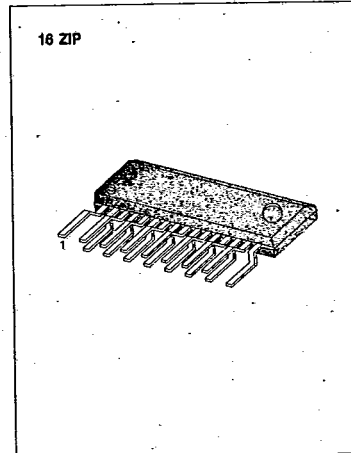

BLOCK DIAGRAM

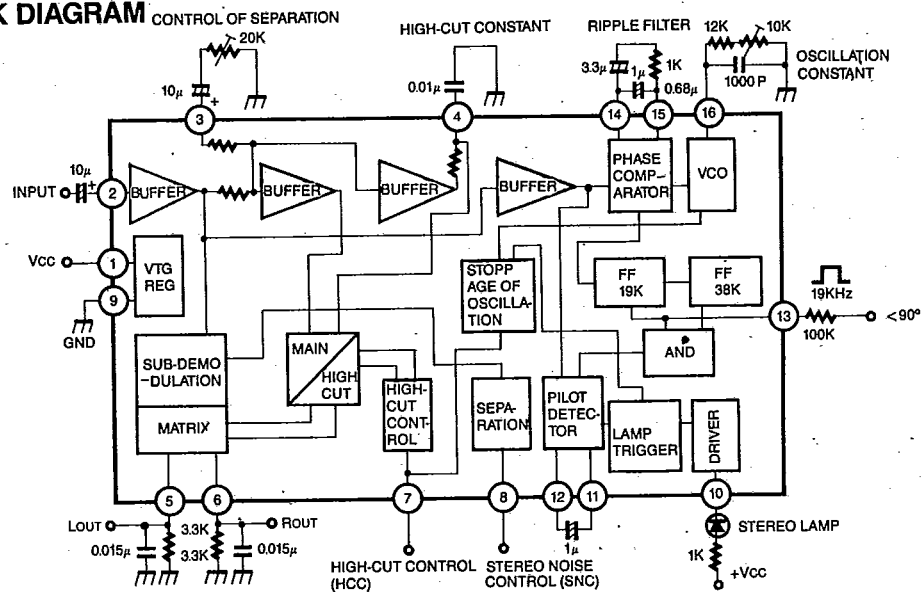

Note: There exists a possibility of change on the VCO Oscillation Constant.

Fig. 1

KA2262

LINEAR INTEGRATED CIRCUIT

ABSOLUTE MAXIMUM RATINGS ($T_a = 25^\circ\text{C}$)

Characteristic	Symbol	Value	Unit
Supply Voltage	V_{CC}	16	V
Lamp Current	I_L	40	mA
Power Dissipation	P_d ($T_a \leq 45^\circ\text{C}$)	520	mW
Operating Temperature	T_{opr}	-20 ~ +70	$^\circ\text{C}$
Storage Temperature	T_{stg}	-40 ~ +125	$^\circ\text{C}$

ELECTRICAL CHARACTERISTICS

($T_a = 25^\circ\text{C}$, $V_{CC} = 10\text{V}$, $f = 1\text{KHz}$, $R_L = 3.3\text{K}\Omega$, unless otherwise specified)

Characteristic	Symbol	Test Conditions	Min	Typ	Max	Unit
Quiescent Circuit Current	I_{CC}	$V_i = 0$		21	27	mA
Channel Separation	Sep	$V_i = 300\text{mV}$, $L+R=90\%$, $P=10\%$	40	50		dB
Total Harmonic Distortion	Mono	THD1 $V_i = 300\text{mV}$		0.05	0.2	%
	Stereo	THD2 $V_i = 300\text{mV}$, $L+R=90\%$, $P=10\%$		0.05	0.2	%
Output Voltage	V_o	$V_i = 300\text{mV}$, Sub	140	200	280	mV
Channel Balance	CB	$V_i = 300\text{mV}$		0.5	1.5	dB
Lamp on Level	V_L (on)	$L+R=90\%$, $P=10\%$	60	85	120	mV
Lamp Hysteresis	HY			3	6	dB
Maximum Input Level	V_i (max)	$L+R=90\%$, $P=10\%$, THD=1%	700	800		mV
SCA Rejection Ratio	SCA Rej	$L+R=90\%$, $P=10\%$		80		dB
Signal to Noise Ratio	S/N	$V_i = 300\text{mV}$	70	78		dB
Ripple Rejection	RR			35		dB
Capture Range	CR	$P=30\text{mV}$		± 3		%
Input Impedance	R_i			20		$\text{K}\Omega$
SNC Output Attenuation	$\text{SNC}_{(ATT)}$	$V_8 = 0.6\text{V}$, $L-R=90\%$, $P=10\%$	-8.5	-3.0	-0.3	dB
SNC Output Voltage	$\text{SNC } V_o$	$V_8 = 0.1\text{V}$, $L-R=90\%$, $P=10\%$			5	mV
HCC Output Attenuation	$\text{HCC}_{(ATT) 1}$	$V_7 = 0.6\text{V}$, $L+R=90\%$, $P=10\%$	-15.0	-6.0	-0.5	dB
	$\text{HCC}_{(ATT) 2}$	$V_7 = 1\text{V}$, $L+R=90\%$, $P=10\%$	-2.0		0	dB

T-77-05-09

KA2262

LINEAR INTEGRATED CIRCUIT

TEST CIRCUIT

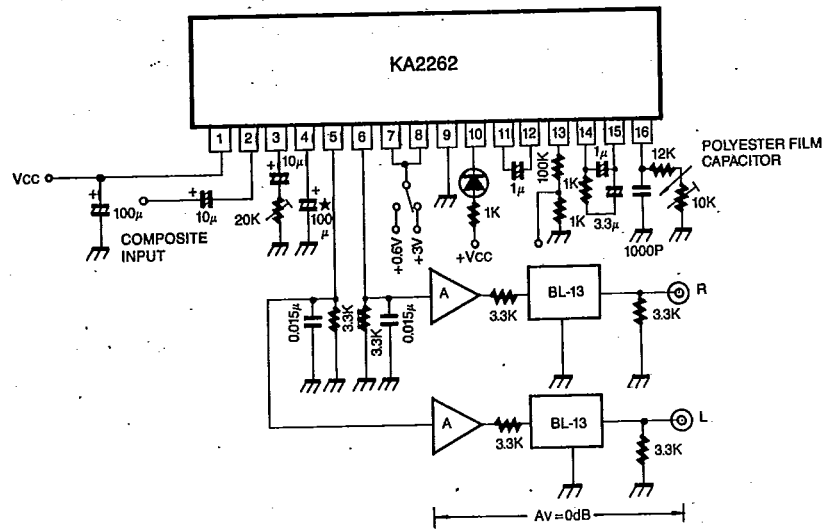

★:100µF connected between pin 4 and GND is for measurement of SNC output voltage, HCC output voltage.

Fig. 2

KA2262**LINEAR INTEGRATED CIRCUIT****SNC (STEREO NOISE CONTROL) AND HCC (HIGH-CUT CONTROL)**

In order to ameliorate the signal to noise (S/N) ratio in the weak electric field, both SNC and HCC Terminals are installed in KA2262. When the SNC Terminal is controlled, the noise particular on the stereo reception in the weak electric field can be decreased.

By using the HCC Terminal, the FM noise at the high-frequency level can be reduced, resulting in the effective improvement of S/N ratio. (Refer to Fig. 4)

As shown in Fig. 4 the deterioration of S/N ratio is larger by approx. 21.7dB in the stereo mode than in the Monaural mode, as far as the weak electric field is concerned.

In general, the noise is considerably harsh (offensive) to the ear if the S/N ratio is lower than 30 ~ 40dB. So, the Areas "A", "B" and "C" have, in this study, been prepared, as shown in Fig. 4, according to the intensity of electric field on a provisional criteria of 30 ~ 40dB (S/N ratio).

The procedures of setting SNC and HCC are described below on the presumption of SNC operation in Area "A" and of HCC operation in Area "B".

Regarding the Area "C", a light level of muting is made at the IF stage.

1. SNC (Stereo Noise Control)

The S/N ratio of stereo reception is worse by 21.7dB in comparison with the monaural reception. However, such S/N ratio can be ameliorated if the separation of stereo reception is changed. The effect of S/N-ratio amelioration can become significant when the separation is less than approx. 20dB. The relationships between this separation and the degree of S/N improvement are shown in Fig. 5.

Under the SNC utilized in KA2262, the S/N ratio improvement is accomplished in the weak electric field by the alteration of separation mentioned above. In details, the separation of stereo reception is controlled by changing the demodulation level of this sub-signal.

If the level output of signal meter in IF stage is utilized as the source of control signal, the S/N ratio can be made lower than approx. 40dB in the Area "A" shown in Fig. 4.

In the case of an idealistic S/N-ratio improvement, a gradual conversion should be made from stereo mode to monaural mode so that the S/N ratio may be constant from the point of stereo S/N ratio, 40dB, to that of monaural S/N ratio, 40dB. The procedures of setting control level will be described later.

In Fig. 6, are shown the relationships between the voltage applied to Pin 8 (SNC Terminal) of KA2262 and the characteristics of separation (SNC characteristics).

Since Pin 8 is positioned at the base of common-collector PNP transistor, the unit is set in the stereo mode if Pin 8 is open. In contrast, it is set in the monaural mode when Pin 8 is grounded.

The control through the use of SNC Terminal is available only when the stereo indicator lights on by the locking to the pilot signal.

Since the SNC control current is less large, the constant of outer circuit can be set at a large amount, resulting in no influence on the meter output circuit of IF stage. Thus, the designing work of this circuit can easily be made.

2. Design of Outer Circuit for SNC Characteristics (Setting Characteristics through Drawing)

The SNC characteristics can be set in order to change the separation smoothly from stereo mode to monaural mode in Area A shown in Fig. 4. The following procedures are preferable for such a setting.

Relationships between separation and improvement of S/N ratio Fig. 5

Relationships between voltage applied to SNC terminal and separation characteristics Fig. 6

If both the "graph" showing the relationships between signal meter output (in IF stage) and antenna input and the "graph" which shows the relationships between antenna input and S/N ratio improvement characteristics are obtained by using Figs. 5 and 6, the relationships between antenna input and S/N ratio improvement characteristics can be obtained through the preparation of drawing.

Also, the characteristics of SNC-terminal application voltage can adversely be obtained from the S/N characteristics which is desirable for the user.

An example of drawing preparation is shown in Fig. 8. In order to simplify the recognition, all of "SNC characteristics", "IF meter characteristics" and "stereo S/N-ratio characteristics" are similarized each other with straight lines.

The example of preparation is as follows:



KA2262

LINEAR INTEGRATED CIRCUIT

The stereo S/N-ratio improvement characteristics are obtained from the SNC characteristics. In the chart diagram, (a) of the 2nd sector is a base SNC characteristics. Through the projection to the 3rd sector from (a), the separation is 20dB at Point "1" while the level of S/N-ratio improvement is 1dB there at.

When projection is made from the 1st sector to the 4th sector, the point where S/N ratio is improved by 1dB from the line of stereo S/N ratio in the 4th sector corresponds with Point 1.

Similarly, Point 2 on SNC characteristics in the 2nd sector corresponds with Point 2 in the 4th sector as well as Point 3 in the 2nd sector with Point 3 in the 4th sector. Thus, the individual S/N-ratio improvement characteristics can be obtained.

Similarly to the above, the characteristics (b) of 2nd sector is projected like Characteristics (b) of 4th sector, while the Characteristics (c) of 2nd sector is projected like Characteristics (c) of 4th sector. Thus, the drawing of improvement characteristics can be prepared.

As a result of preparation of drawing, the S/N-ratio improvement characteristics of Fig. (b) in the 4th sector is Idealistic. However, the SNC characteristics corresponding therewith becomes the characteristics shown with Fig. (b) of 2nd sector. It is difficult to realize such characteristics.

From the viewpoint of practical characteristics, the one like Fig. (c) seems to be appropriate. The SNC characteristics shown in Fig. (c) are obtained by the use of both the shifting operation made by 2 diodes and 1/2 bleeder.

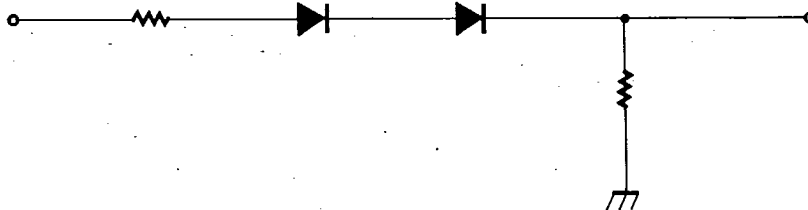

3. HCC (High-Cut Control)

In Area B where the S/N ratio is lower than 40dB even in the monaural mode, the S/N ratio can be improved from the acoustic standpoint if the level of high frequency (at about 7 KHz) is lowered.

When the signal meter output voltage of IF stage is given to the HCC Terminal (Pin 7) of KA2262, a smooth high-level attenuation (high-cut control) can be made according to the meter's voltage.

In Fig. 9, are shown the frequency characteristics (monaural) of MPX output caused from the voltage applied to Pin 7. The frequency characteristics obtained when 100% high cut is made can freely be set by the 4-pin outer capacitor.

The equivalent circuit at this stage is determined by the time constant of "5K Ω " and "C", as shown in the following diagram. By the approx. amount by C, the degree of attenuation at 10KHz. is as follows:

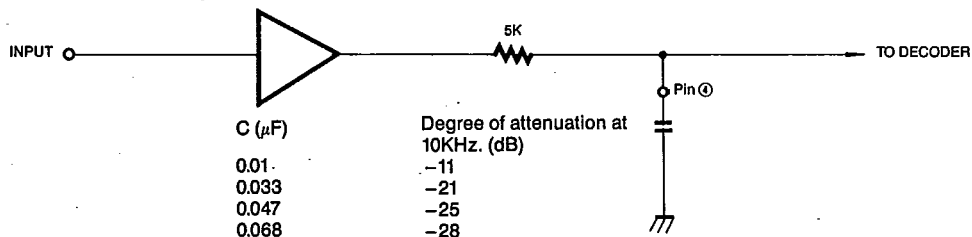

The relationships (HCC characteristics) between Pin 7 applied voltage and high-cut rate (%) are shown in Fig. 10. When the characteristics of IF meter output voltage and the S/N-ratio characteristics of Area B (shown in Fig. 4) are obtained in addition to Fig. 10, the characteristics of S/N-ratio improvement which is implemented by HCC can be drawn.

The output of meter of IF amplifier IC used for quadrature detection is usually the one shown in Fig. 4. (Fig. 3 shows the data of KA22441). Thus, the HCC characteristics (Fig. 10) are set so that the Area B may be ameliorated when the output mentioned above is directly connected with the HCC Terminal (Pin 7) of KA2262.

Being very small similarly to the control current of Pin 8, such control current of Pin 7 gives no influence to the output of meter.

KA2262

LINEAR INTEGRATED CIRCUIT

4. SNC/HCC Connection Circuit when they are connected with IF Stage

In Fig. 3, is shown an example of S/N-ratio characteristics caused from the antenna input when SNC and HCC are connected with the IF stage through the outer circuit shown below.

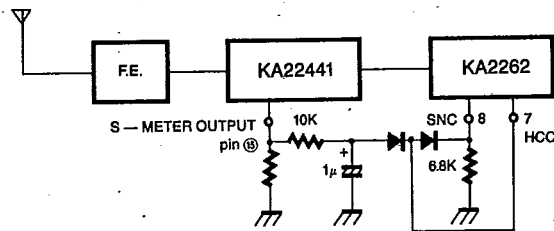

5. Improvement of S/N Ratio in Area C shown in Fig. 3

In Area C shown in Fig. 3, the S/N ratio is further worsened. Its improvement should be performed by the IF muting. The KA22441 can be enumerated as an IC which can vary this IF muting linearly. The S/N-ratio improvement effect of KA2262 can further be enhanced if KA2262 is used together with KA22441.

6. Use of HCC Terminal for the Muting Function

In the event that the removal of high-frequency noise is not required when HCC Terminal is used for a home-enjoyed stereo unit, etc., the muting can be accomplished by approx. 37dB if this HCC function is utilized for the muting function.

If the time constant is applied on the control of Pin 7, the "Fade In" and "Fade Out" operations can be performed on the muting. The muting can be performed without offensiveness to the ear as alien factors such as shock noise, etc. are removed thereby.

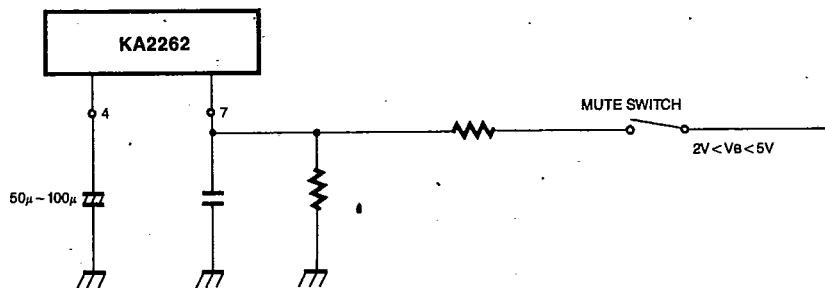

T-77-05-09

KA2262

LINEAR INTEGRATED CIRCUIT

7. Stop Method of VCO

When a voltage higher than 7V is applied to the HCC Terminal (Pin 7), the oscillation of VCO can be discontinued, resulting in the Monaural Mode. At this stage, both SNC and HCC are in the OFF status. The relationships between the incoming current and Pin 7 applied voltage are shown in Fig. 11.

8. Separation Control Terminal

The control of separation is implemented by controlling the level of main signal. The range of separation of the controllable input compost signal (Sub-signal/main signal ratio) is approx. the one shown in the following formula.

$$m = \frac{\text{Sub signal level}}{\text{Main signal level}} \quad \begin{matrix} 0.7 < m < 1.25 \\ \text{(At peak level)} \end{matrix}$$

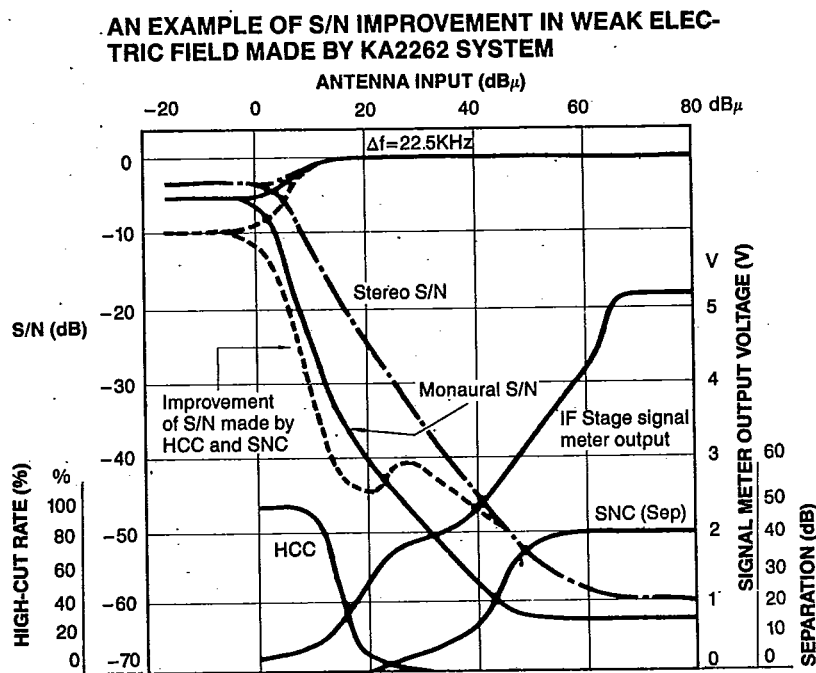

Fig. 3

KA2262

LINEAR INTEGRATED CIRCUIT

CHART DIAGRAM USED FOR OBTAINING STEREO CHARACTERISTICS FROM SNC CHARACTERISTICS

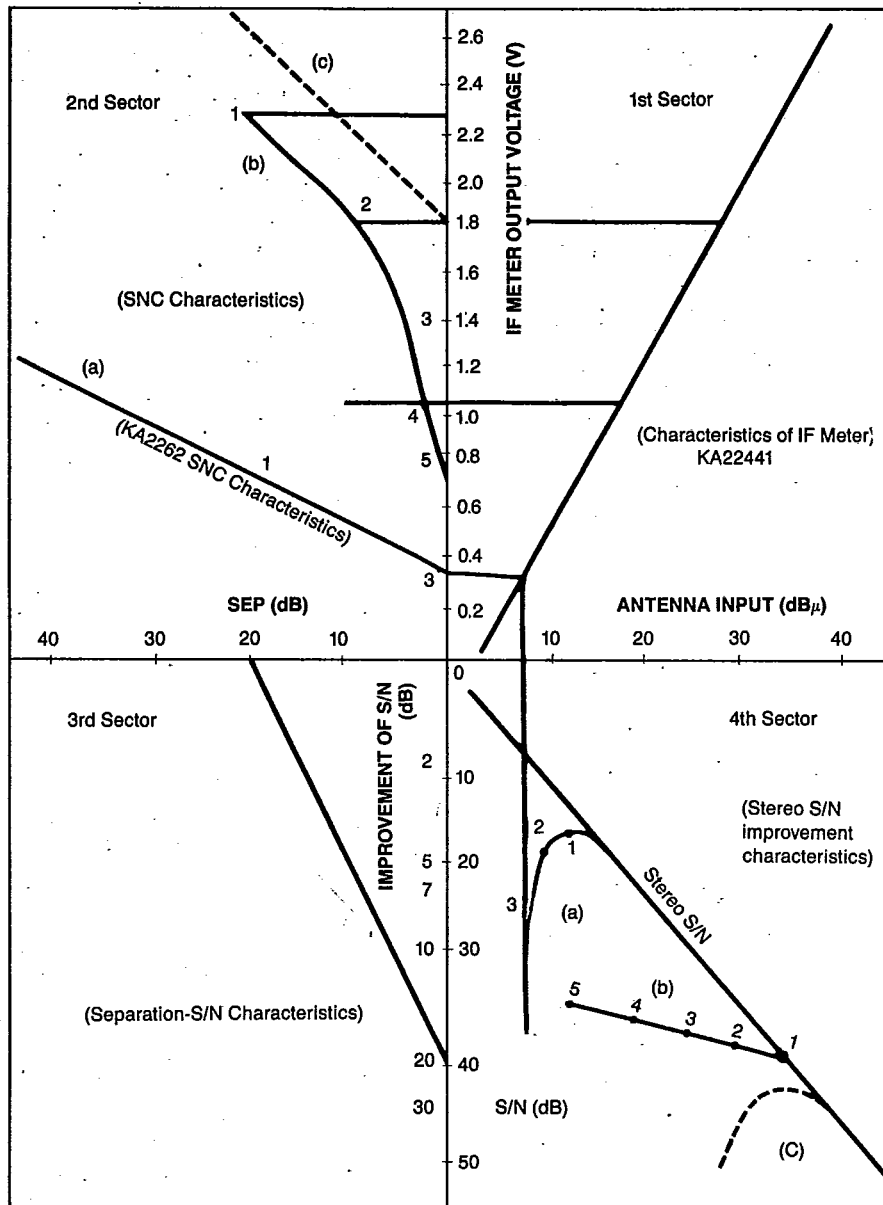
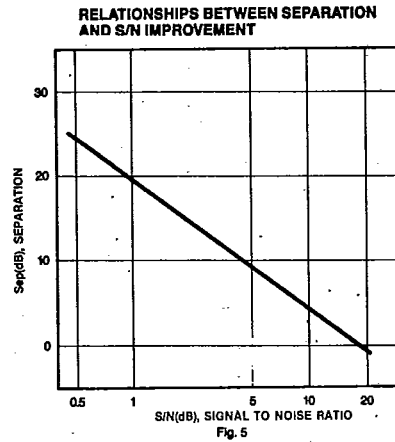
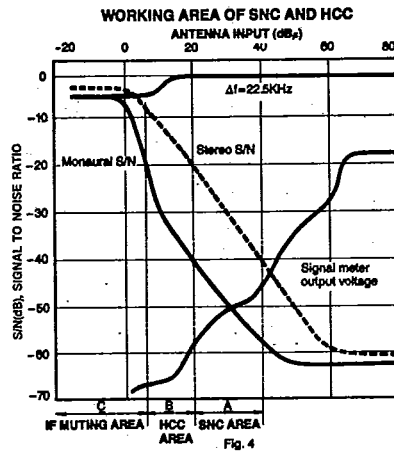

Fig. 8

KA2262

LINEAR INTEGRATED CIRCUIT



SNC CHARACTERISTICS (SUB-LEVEL) KA2262 SNC CHARACTERISTICS SNC CHARACTERISTICS (SEPARATION)

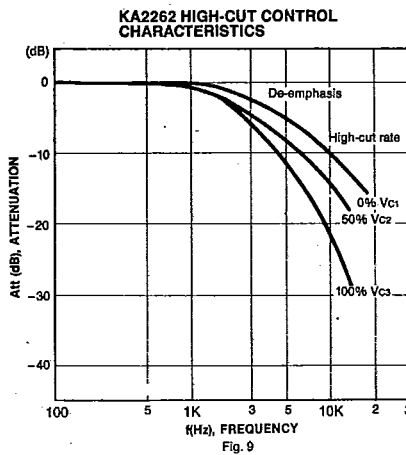
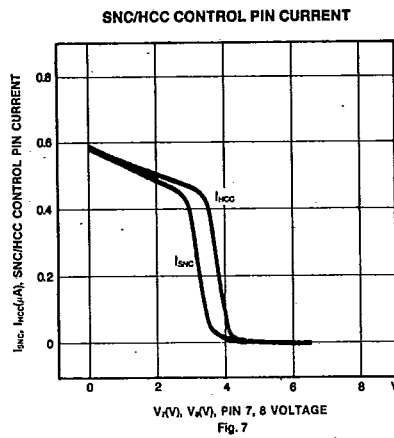
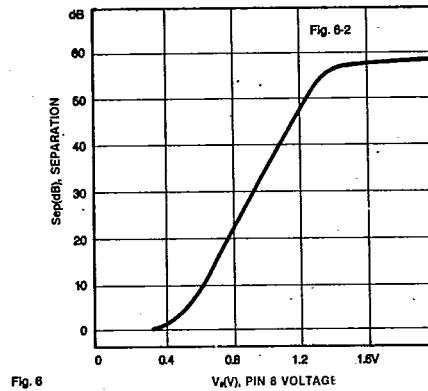
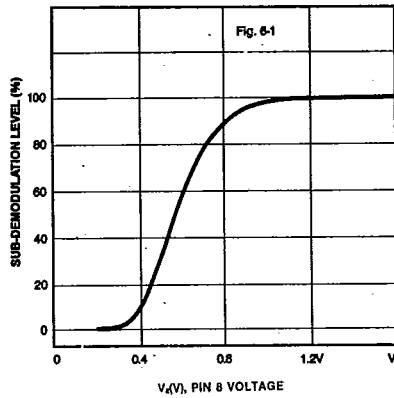

T-77-05-09

KA2262

LINEAR INTEGRATED CIRCUIT

KA2262 HCC CHARACTERISTICS

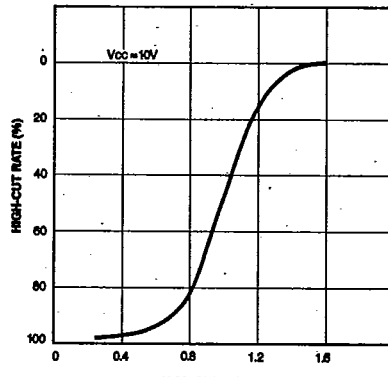

V(V), PIN 7 VOLTAGE
Fig. 10

CHARACTERISTICS OF CURRENT AT VCO STOP FUNCTION CONTROL TERMINAL

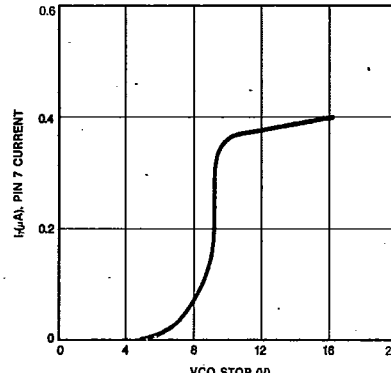

VCO STOP (V)
Fig. 11

3