

**5-DOT DUAL LED LEVEL METER DRIVER**

The KA2284/KA2285 are a monolithic integrated circuits designed for 5-dot LED level meter drivers with a built-in rectifying amplifier; it is suitable for AC/DC level meters such as VU meters or signal meters.

**FEATURES**

- High gain rectifying amplifier included ( $G_v = 26\text{dB}$ ).
- Low radiation noise when LED turns on.
- Logarithmic indicator for 5-dot LED of bar type.  
(-10, -5, 0, 3, 6dB)
- Constant current output.  
KA2284:  $I_o = 15\text{mA Typ.}$   
KA2285:  $I_o = 7\text{mA Typ.}$
- Wide operating supply voltage range:  $V_{cc} = 3.5\text{V} \sim 16\text{V}$
- Minimum number of external parts required.

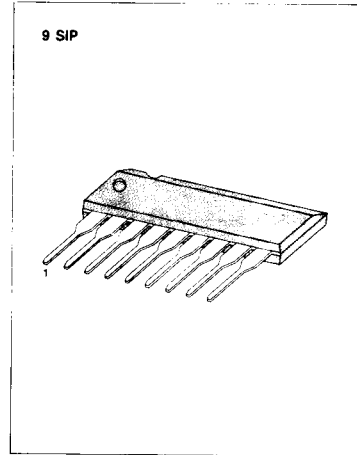

**BLOCK DIAGRAM**

**ORDERING INFORMATION**

Device	Package	Operating Temperature	$I_o$
KA2284	9 SIP	-20°C ~ +80°C	15 mA
KA2285			7 mA

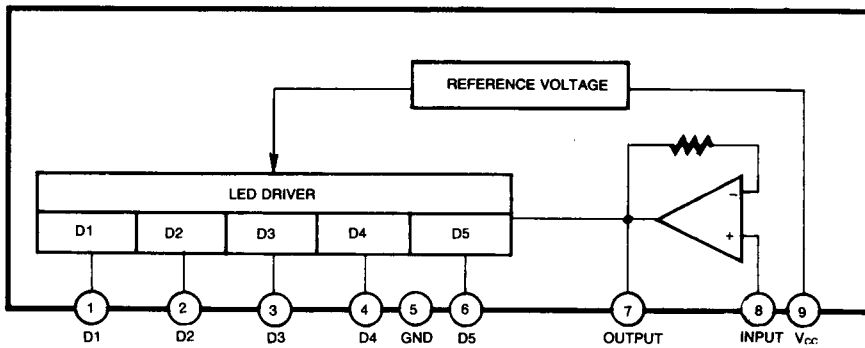

\*Capacitor to be omitted when used as a DC input signal meter

Fig. 1

ABSOLUTE MAXIMUM RATINGS ( $T_a = 25^\circ\text{C}$ )

Characteristic	Symbol	Value	Unit
Supply Voltage	$V_{CC}$	18	V
Amp Input Voltage	$V_{I(8-5)}$	$-0.5 \sim V_{CC}$	V
Pin 7 Voltage	$V_{7.5}$	6	V
D Terminal Output Voltage	$V_D$	18	V
Circuit Current	$I_{CC}$	12	mA
D Terminal Output Current	$I_D$	20	mA
Power Dissipation	$P_D$	1100	mW
Operating Temperature	$T_{OPR}$	$-20 \sim +80$	$^\circ\text{C}$
Storage Temperature	$T_{STG}$	$-40 \sim +125$	$^\circ\text{C}$

-11mW/ $^\circ\text{C}$  is decreased at higher temperature than  $T_a = 25^\circ\text{C}$ .

## ELECTRICAL CHARACTERISTICS

( $T_a = 25^\circ\text{C}$ ,  $V_{CC} = 6\text{V}$ ,  $f = 1\text{KHz}$ , unless otherwise specified)

Characteristic	Symbol	Test Conditions	Min	Typ	Max	Unit
Circuit Current	$I_{CCO}$	$V_i = 0\text{V}$		6	8.5	mA
D Output Current	KA2284	$V_i = 0.15\text{V}$	11	15	18.5	mA
	KA2285		5	7	9.5	
Input Bias Current	$I_{BIAS}$		-1		0	$\mu\text{A}$
Amp Gain	$G_V$	$V_i = 0.1\text{V}$	24	26	28	dB
Comparator ON Level	$V_{CL(ON)}$	$V_{CL(ON)1}$	-12	-10	-8	dB
		$V_{CL(ON)2}$	-6	-5	-4	
		$V_{CL(ON)3}$		0		
		$V_{CL(ON)4}$	2.5	3	3.5	
		$V_{CL(ON)5}$	5	6	7	

\* Definition of 0dB: input voltage level when  $V_{CL(ON)3}$  turn ON. (50mV)

TEST CIRCUIT

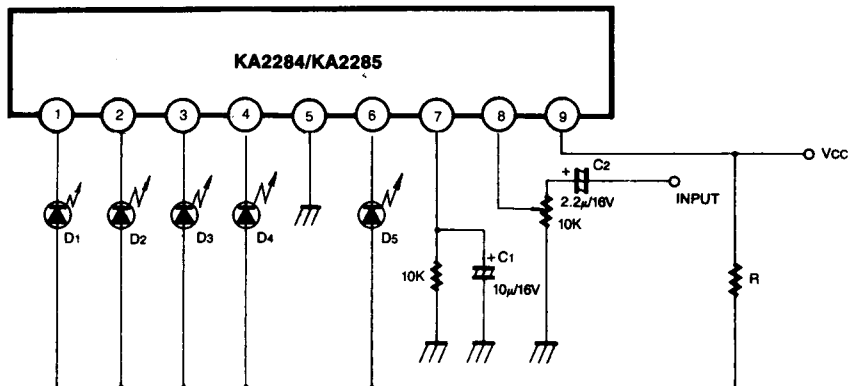

Fig. 2

C<sub>2</sub>: AC in, 2.2µ is used.  
DC in, 2.2µ is shorted

The recommended value of R at T<sub>a</sub> (max)=60°C.

V <sub>CC</sub> (V)	8 ~ 12	10 ~ 14	12 ~ 16
R (Ω)	47	68	91

By changing the time constant C<sub>1</sub> and C<sub>2</sub>, the response, attack and release time, may be varied. In the above application conditions, power dissipation may be operated at higher levels than the absolute maximum ratings. The wattage of R is to be determined by the total LED current and R value recommended by the R table.