

HED8...type Pressure Relay

HED8...1XJ...type

Max. Working Pressure: 350bar



Contents

Function and configuration	02
Specifications	03
Characteristic curves	03
Technical data	04
Unit dimensions	05
Installation guidelines	06
For the pressure switch type HED 8...as a sandwich (350bar)	07-08
Transition plate when pressure switch type HED8 OH substitutes HED4 OH	09
Terminal allocation	09

Function and configuration

HED8 type relay is a piston pressure switch. It consists of the housing (1), cartridge with spool (2), compression spring (3), adjustment element (4) and micro-switch (5).

If the pressure to be monitored is below the set value then the micro-switch (5) is actuated. The pressure fluid is applied to the piston (2) via orifice (7). The piston (2) supports itself on the spring seat (6) and acts against the infinitely adjustable force of the compression spring (3). The spring seat (6) transfers the movement of the piston (2) to the micro-switch (5). The micro-switch (5) is released when fluid setting pressure is reached.

The electrical circuit is either switched on or off according to the circuit design. The mechanical stop of the spring seat (6) protects the micro-switch (5), in the case of sudden pressure loss, from mechanical destruction and prevents the compression spring (3) from damaging if an overpressure occurs.

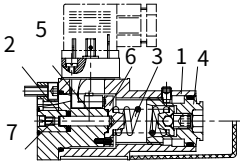

Type HED 8 OH-1XJ/...K14 "S..."

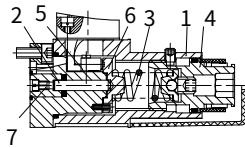

Type HED 8 OH-1XJ/...K14 A AS...

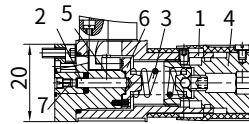

Type HED 8 OH-1XJ/...K14 KW

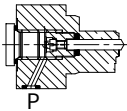

Type HED 8 OP-1XJ...

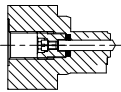

Type HED 8 OA-1XJ...

Symbols

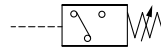

Specifications

	HED8	-1XJ /		/		*	
Pressuer relay							Further details in clear text
Vertical stacking systems = OH							No code = NBR seals
Sub-plate mounting = OP							V = FKM seals
Pipe installation = OA							
Series 10J to 19J (10J to 19J: unchanged installation and connection dimensions)		=1XJ					Connection thread: No code= Inch threaded (G1/4) 2 = Metric threaded (M14×1.5)
Max. setting pressure 50bar		=5					No code= Spindle (without scale)
Max. setting pressure 100bar		=10					S= Spindle (without scale)with protective cap
Max. setting pressure 200bar		=20					A= Spindle with scale
Max. setting pressure 350bar		=35					AS= Spindle with scale and protective cap
Electrical connection type							KW= Rotary knob with scale
Plug-in		=Z14					
Plug-in with light (DC24V)		=L24					

Characteristic curves (Measured at t=40°C ±5°C , using HLP46)

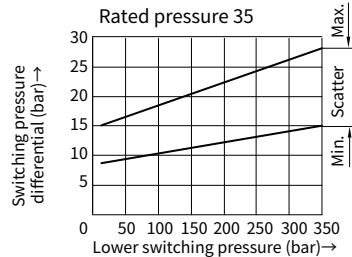
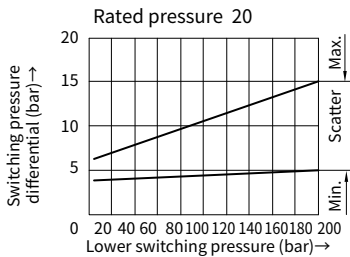
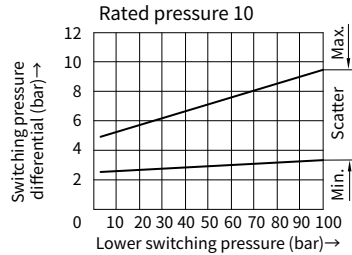
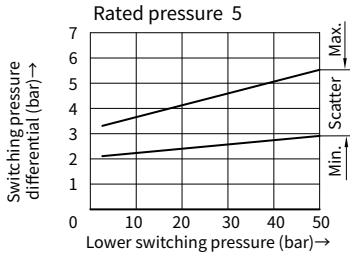

Technical data

Weight	- Pressure switch	kg	0.8
	- Sandwich plate for vertical stacking assemblies	kg	0.8 (NS 6, plate height 40.5 mm)
			3 (NS 6, plate height 120 mm) 2 (NS 10)
Fluid		Mineral oil suitable for NBR and FKM seal Phosphate ester for FKM seal	
Fluid temperature range		°C	- 20 to + 80 (for FKM seals) - 30 to + 80 (for NBR seals)
Viscosity range		mm ² /s	2.8 to 500
Degree of contamination		Maximum permissible degree of fluid contamination: Class 9. NAS 1638 or 20/18/15, ISO4406	
Switching accuracy (repeatability)		< ± 1 % of setting range	
Permissible switching frequency		times/min.	80
Pressure setting range			
Pressure rating (Max. setting pressure) (bar)		Max. operating pressure (bar)	Pressure setting range (bar)
50		350	2 to 50
100		350	4 to 100
200		350	5 to 200
350		500	8 to 350
Electrical connection		plug-in connector to DIN 43 650, form A, 3-pin + PE	
Max. connection cross sectional area		mm ²	0.5
Max. contact load	-AC	250V/5A	
	-DC	50V/1A;125V/0.03A;250V/0.02A	
Protection to DIN 40 050		IP65	
With DC inductive loading, a spark suppressor must be provided in order to increase the service life.			

Unit dimensions

(Dimensions in mm)

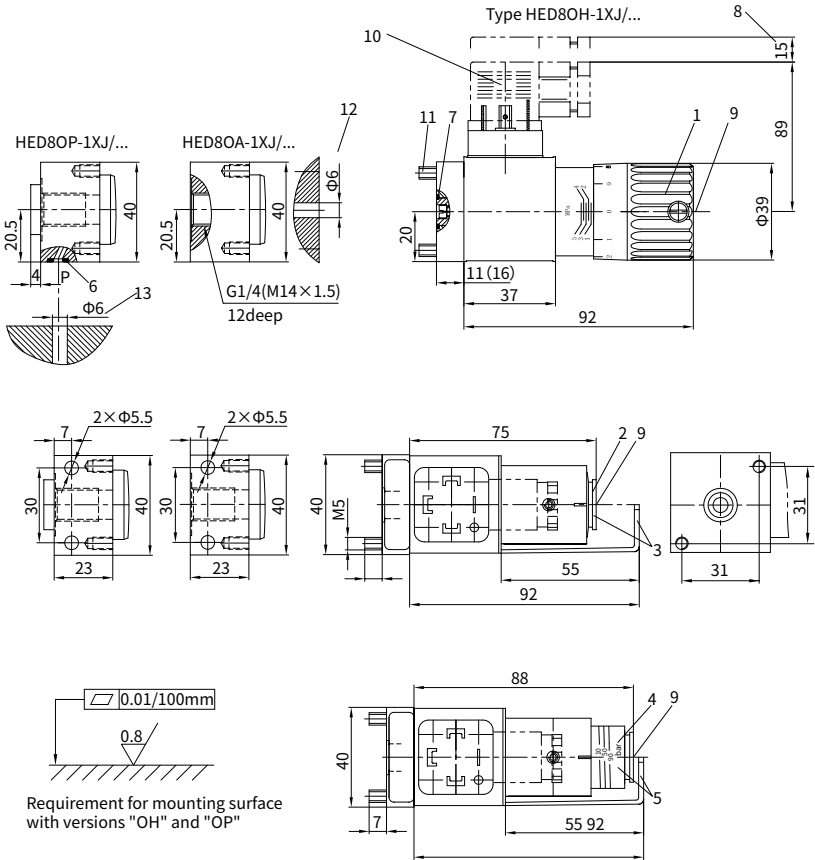

- 1 Adjustment element "KW"
- 2 Adjustment element "-"
- 3 Adjustment element "S"
- 4 Adjustment element "A"
- 5 Adjustment element "AS"
- 6 O-ring 5.3×1.8
- 7 O-ring 10.82×1.78
- 8 Space required to remove the plug-in
- 9 Internal hexagon nut A/F 10
- 10 Plug-in connector without cable to DIN 43 650

11 Valve fixing screws:

2- M5×12 GB/T 70.1-10.9,
tightening torque $M_A=8.9\text{Nm}$

12 Maximum diameter of the mounting surface of the matting piece (type HED8 OH 1XJ/...)

13 Maximum diameter of the mounting surface of the matting piece (type HED8 OP 1XJ/...)

Installation guideline

(Dimensions in mm)

· For applying the pressure relay HED4OH...in stacking assemblies size 6

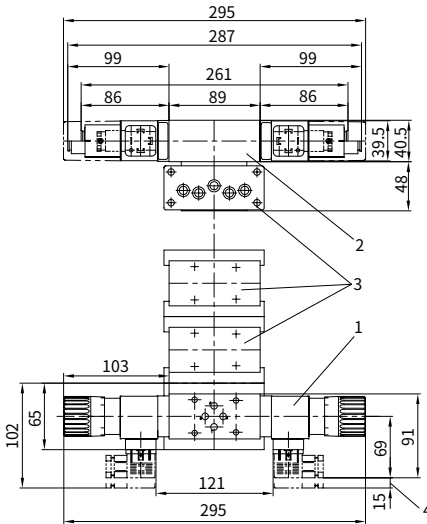

- 1 Pressure switch HED8 OH... for use in stacking assemblies (can be rotated $4 \times 90^\circ$ for mounting). The mounting possibilities of the pressure switch depends on the design of the adjacent stacking plates
- 2 Sandwich plate type HSZ 06 for mounting the pressure switch as a stacking element.
- 3 Stacking elements.
- 4 Space required to remove the plug-in.

· For applying the pressure relay ED4OH...in stacking assemblies size 10

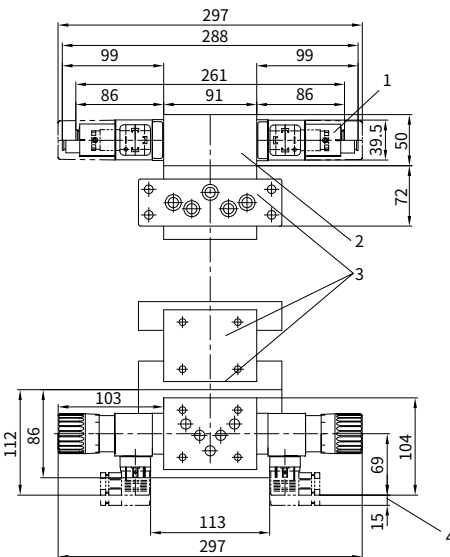

- 1 Pressure switch HED8 OH... for use in stacking assemblies (can be rotated $4 \times 90^\circ$ for mounting). The mounting possibilities of the pressure switch depends on the design of the adjacent stacking plates
- 2 Sandwich plate type HSZ 10 for mounting the pressure switch as a stacking element.
- 3 Stacking elements.
- 4 Space required to remove the plug-in.

For the pressure relay type HED 8...as a sandwich (350bar) (Dimensions in mm)

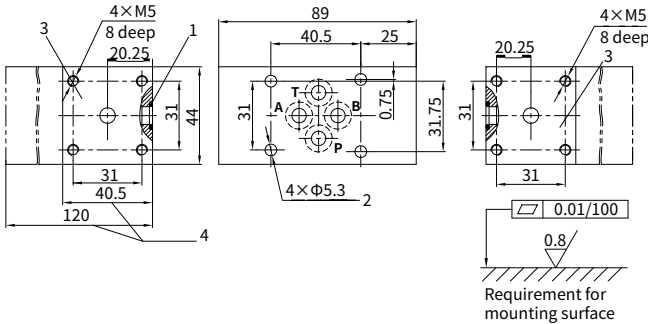

- 1 O-ring 9.25×1.78
- 2 Through holes for valve fixing
- 3 Mounting surface for pressure switch
- 4 Plate height 40.5 mm or 120 mm, optional.

Specification

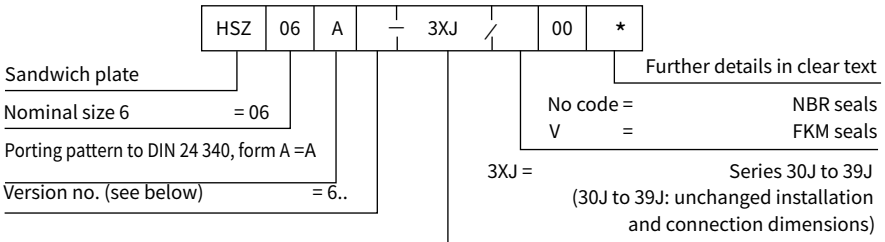

Sandwich plate NS 6: symbols, version no.(version no. in () for 120 mm plate height)

(① =valve side; ② =sub-plate side)

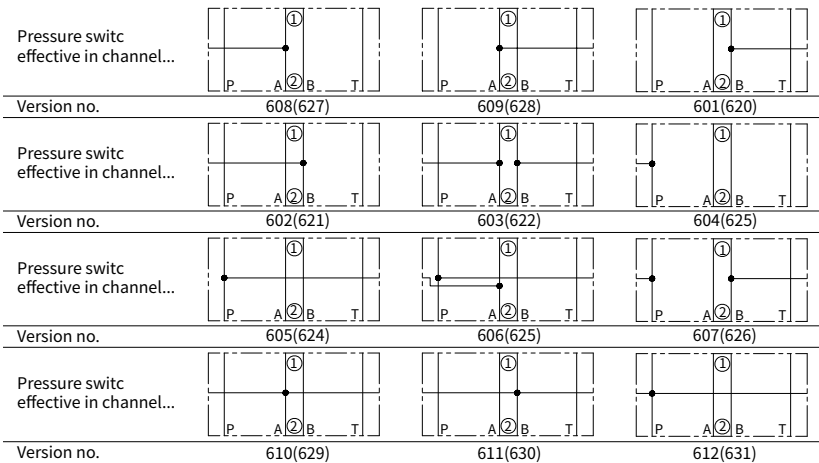

For the pressure relay HED 8...as a sandwich (350bar)

(Dimensions in mm)

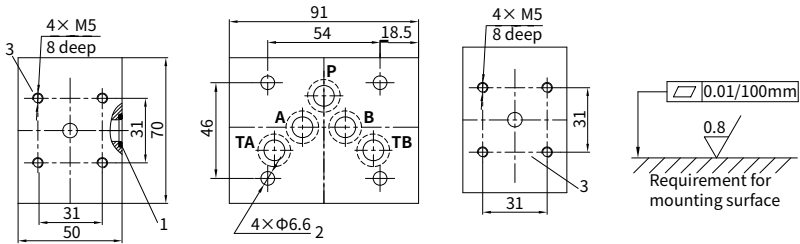

- 1 O-ring 12×2
- 2 Through holes for valve fixing
- 3 Mounting surface for pressure switch

Specification

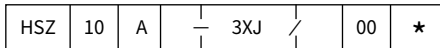

Sandwich plate

Nominal size 10 = 10

Porting pattern to DIN 24 340, form A=A

Version no. (see below) = 6..

Further details in clear text

No code = NBR seals

V = FKM seals

3XJ = Series 30J to 39J
(30J to 39J: unchanged installation and connection dimensions)

Sandwich plate NS 6: symbols, version no. (① =valve side; ② =sub-plate side)

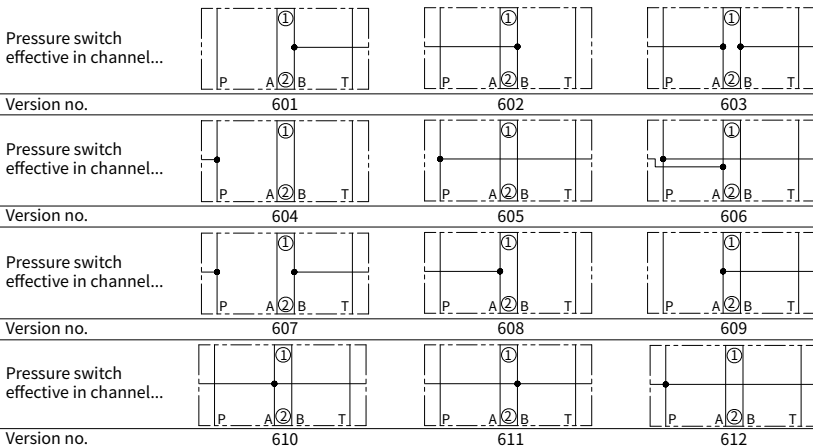

Transition plate when pressure relay type HED80H substitutes HED40H

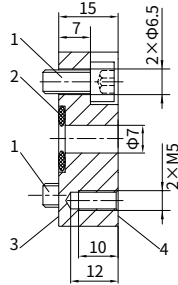
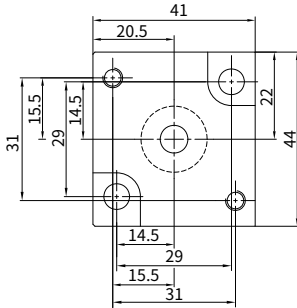

- 1 Fixing screws: 2- M6×16
GB/T 70.1-10.9,
tightening torque $M_A=8.9\text{Nm}$
- 2 O-ring 13×2
- 3 Mounting surface for
pressure switch type HED4
- 4 Mounting surface for pressure
switch type HED80H

Specification

GD-HED8-4H

Transition plates

NBR seals = No code

FKM seals = V

Terminal allocation

