

Z2FS...type Modular Restrictive Check Valve

Z2FS...30J...type

Sizes 6, 10, 16, 22
Max. Working Pressure: 315 bar
Max. Flow: 360 L/min



Contents

Function and configurations	02
Symbols	02-03
Specifications	04
Technical data	04
Characteristic curves	05
Unit dimensions	06-07

Features

- Sandwich plate valve
- Porting pattern to DIN 24 340 form A and ISO4401
- For limiting the main or control fluid flow of 2 actuator connections
- 3 adjustment elements:
 - Lockable rotary knob with scale
 - Spindle with internal hexagon and scale
 - Rotary knob with scale
- For meter-in or meter-out control

Function and configuration

Z2FS type valve is a modular restrictive check valve with sandwich plate structure.

It is used to control the flow by changing the throttling. In the opposite direction, fluid flows freely through the check valve. For Z2FS10, depending on the installation position, the throttling effect may be arranged as a meter-in or a meter-out control. While for Z2FS16 and 22, depending on the model (S or S2) throttling may take place in either meter-in or meter-out, and the two operating oil chambers are connected.

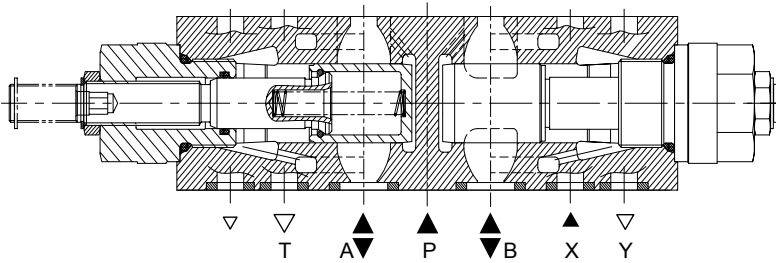

Structure chart of double throttle/Check Valve

Symbols (① = valve side, ② = sub-plate side)

size:6

Type:Z2FS6-30J/ (meter-in control)

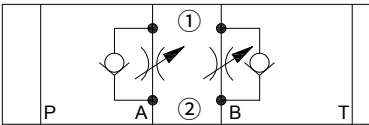

Type:Z2FS6-30J/ (meter-out control)

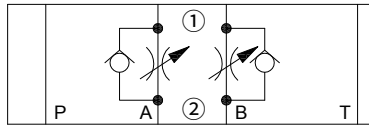

Type:Z2FS6A-30J/ (meter-in control)

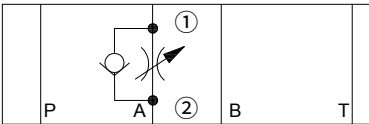

Type:Z2FS6A-30J/ (meter-out control)

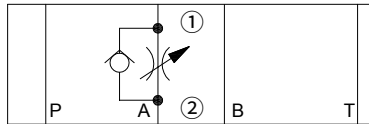

Type:Z2FS6B-30J/ (meter-in control)

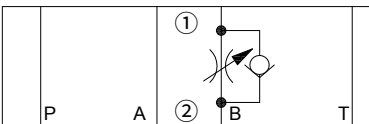

Type:Z2FS6B-30J/ (meter-out control)

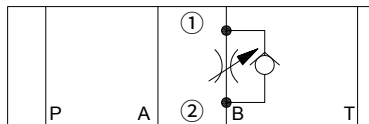

Symbols

(① =valve side, ② = sub-plate side)

size:10

Type:Z2FS10-30J/ (meter-in control)

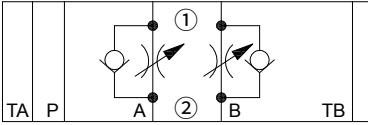

Type:Z2FS10-30J/ (meter-out control)

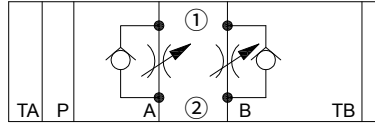

Type:Z2FS10A-30J/ (meter-in control)

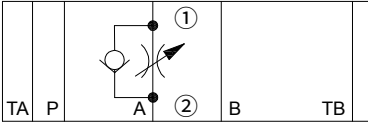

Type:Z2FS10A-30J/ (meter-out control)

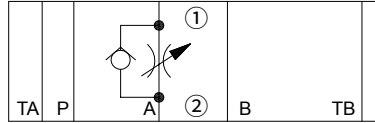

Type:Z2FS10B-30J/ (meter-in control)

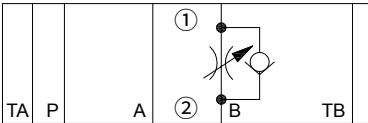

Type:Z2FS10B-30J/ (meter-out control)

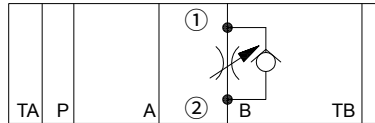

Symbols

(① =valve side, ② = sub-plate side)

size:16, 22

Type:Z2FS...-30J/ (meter-in control)

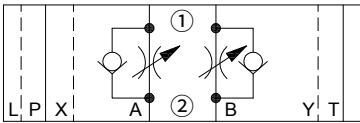

Type:Z2FS...-30J/ (meter-out control)

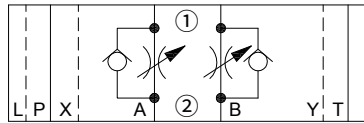

Type:Z2FS...A-30J/ (meter-in control)

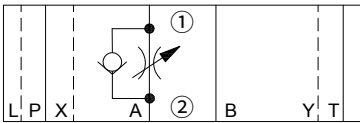

Type:Z2FS...A-30J/ (meter-out control)

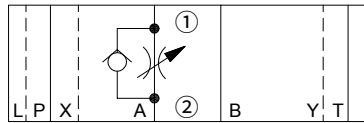

Type:Z2FS...B-30J/ (meter-in control)

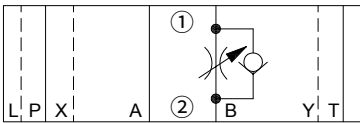

Type:Z2FS...B-30J/ (meter-out control)

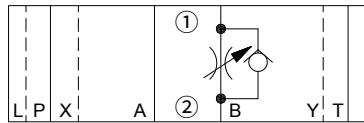

Specification

Z2FS			30J		*
Modular Restrictive check valve					Further details in clear text
Nominal size 6	=6			No code =	NBR seals
Nominal size 10	=10			V =	FKM seals
Nominal size 16	=16				
Nominal size 22	=22			No code=	Meter-in /meter-out control
Throttle/check valve ports A and B = -				S =	Meter-in contro
Throttle/check valve port A = A				S2 =	Meter-out control
Throttle/check valve port B = B					
30J Series			=30J		

Technical data

Installation position	Optional
Flow direction	One direction throttle, return through the check valve by another direction
Fluid	Mineral oil suitable for NBR and FKM seal, Phosphate ester for FKM seal
Fluid temperature range °C	-20 to +80
Degree of contamination	Maximum permissible degree of fluid contamination: Class 9. NAS 1638 or 20/18/15, ISO4406
Viscosity range mm ² /s	10 to 800
Max.operating pressure bar	to 350
Nominal size	6 10 16 22
Weight kg	0.9 3.1 4.7 8

Characteristic curves

(Measured at $t=40^{\circ}\text{C} \pm 5^{\circ}\text{C}$, using HLP46)

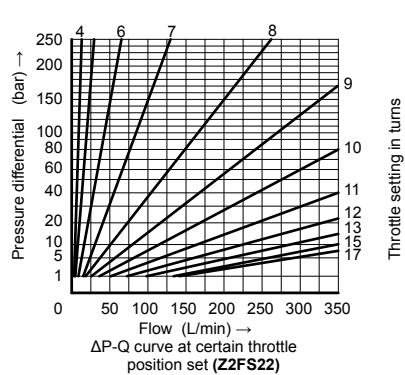
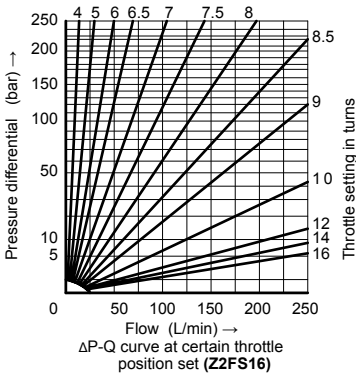
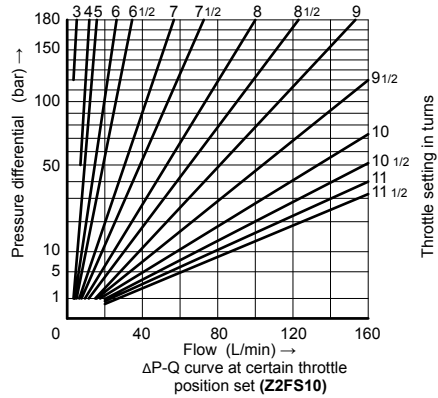
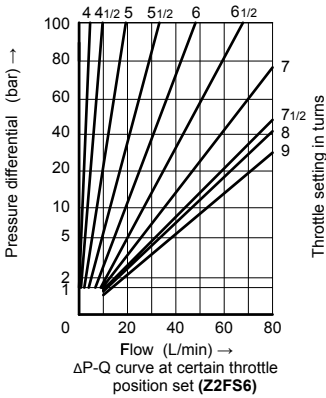
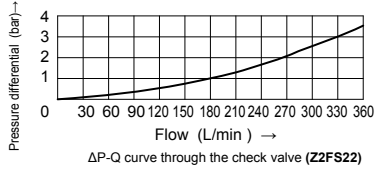
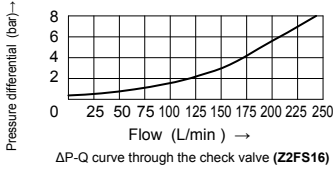
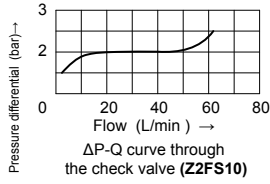
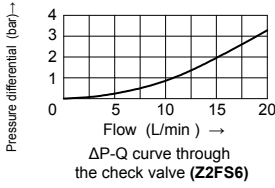

04

Unit dimensions:

(Dimensions in mm)

• Outline dimension of Modular Restrictive Check Valve Type Z2FS6

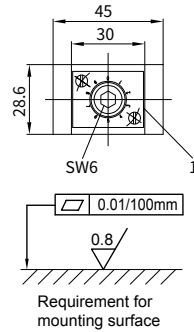
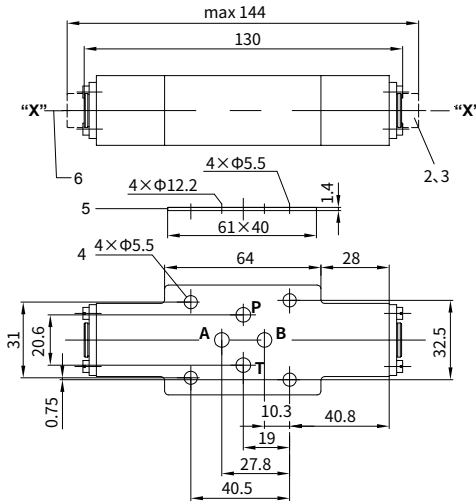

- 1 Nameplate
- 2 Adjustable bolt
- 3 Turn anti-clockwise=increases flow,
turn clockwise=decreases flow
- 4 Valve fixing holes
- 5 O-ring plate
- 6 To change from meter-in to meter-out,
rotate the unit around the "X - X" axis

• Outline dimension of Modular Restrictive Check Valve Type Z2FS10

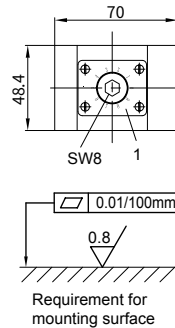
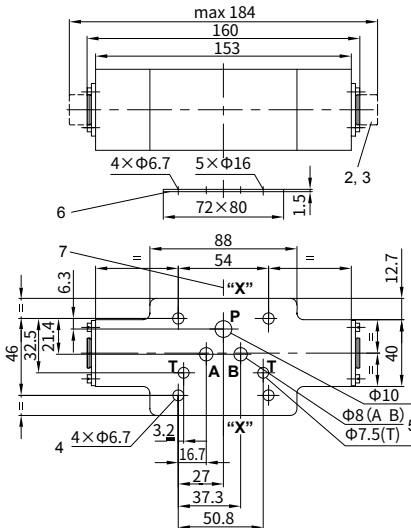

- 1 Nameplate
- 2 Adjustable bolt
- 3 Turn anti-clockwise = increases flow,
turn clockwise = decreases flow
- 4 Valve fixing holes
- 5 Port (A, B, P, T)
- 6 O-ring plate
- 7 To change from meter-in to meter-out,
rotate the unit around the "X - X" axis

Unit dimensions:

(Dimensions in mm)

• Outline dimension of Modular Restrictive Check Valve Type Z2FS16

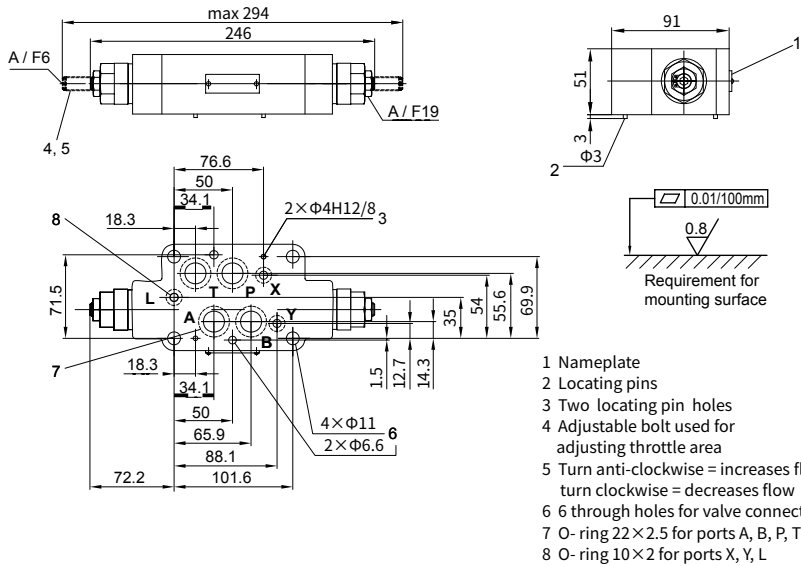

• Outline dimension of Modular Restrictive Check Valve Type Z2FS22

