

AN7317

Dual Recording and Playback Pre-Amplifier IC for Single/Double Cassette

■ Description

The AN7317 is a monolithic integrated circuit designed for radio cassette recorder and built-in record/playback pre-amplifier including ALC and mute function.

■ Features

- Built-in ALC low cut function
- Muting circuit built-in
- Wide operating voltage: $V_{CC} = 3.5V \sim 12V$

■ Pin

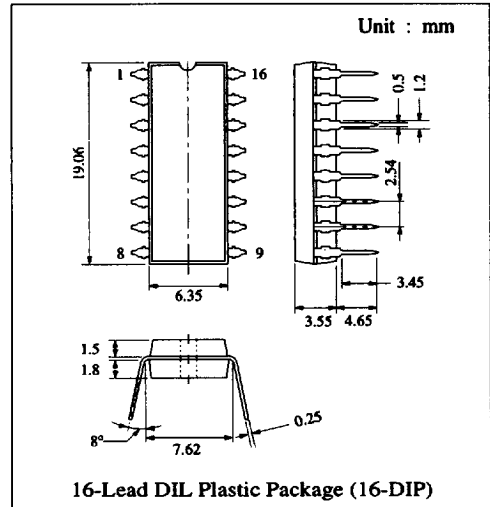

Pin No.	Pin Name	Pin No.	Pin Name
1	Playback Amplifier Input Ch. 1	9	V _{CC}
2	Playback Amplifier Negative Feedback Ch. 1	10	Ripple Filter
3	Playback Amplifier Output Ch. 1	11	Record Amplifier Mute
4	Record Amplifier Input Ch. 1	12	Record Amplifier Output Ch. 2
5	Record Amplifier Output Ch. 1	13	Record Amplifier Input Ch. 2
6	ALC Low-Cut	14	Playback Amplifier Output Ch. 2
7	ALC Time	15	Playback Amplifier Negative Feedback Ch. 2
8	GND	16	Playback Amplifier Input Ch. 2

■ Block Diagram

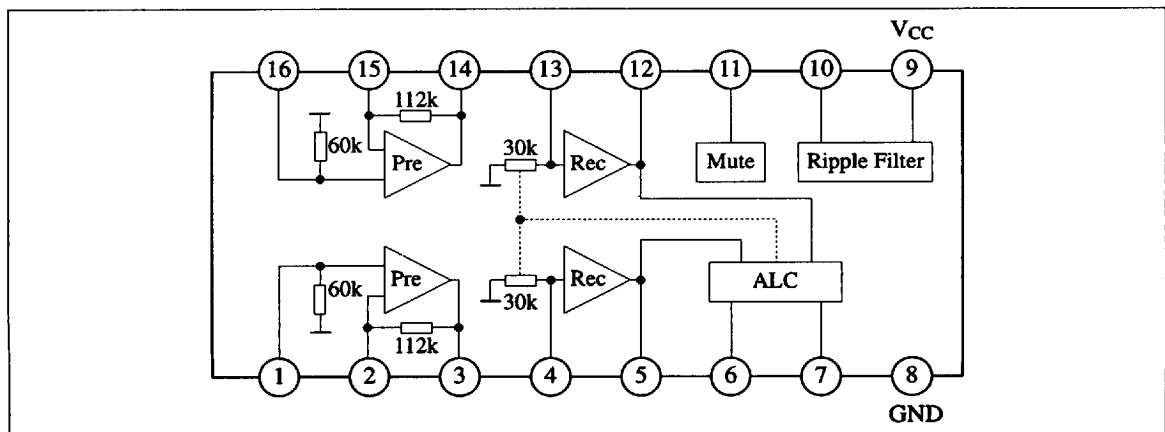

6932852 0013952 032

Panasonic

333

■ Absolute Maximum Ratings (Ta=25°C)

Item	Symbol	Rating	Unit
Supply Voltage	V _{CC}	14	V
Supply Current	I _{CC}	30	mA
Power Dissipation	P _D	800	mW
Operating Ambient Temperature	T _{opr}	-20 ~ +75	°C
Storage Temperature	T _{stg}	-55 ~ +150	°C

Operating Supply Voltage Range: V_{CC} = 3.5V ~ 12.0V

■ Electrical Characteristics (V_{CC}=6V, f=1kHz, V_O=1V, Ta=25°C)

Item	Symbol	Condition	min.	typ.	max.	Unit
No Signal Supply Current	I _{tot}	No Signal Input	7.5	11.1	20.9	mA

Pre-Amp.

Open Loop Gain	G _{VO-P}	R _{NF} Short	81	90		dB
Close Loop Gain	G _{VC-P}	NAB	40	43	46	dB
Maximum Output Voltage	V _{Om-P}	THD = 3%	1.4	1.7		V
Total Harmonic Distortion	THD _P	Filter: 400Hz - 30kHz		0.03	0.1	%
Input Referred Noise	V _{ni-P}	R _g = 2.2kΩ, DIN/AUDIO		1.4	2.0	μV
Channel Crosstalk	CT _P	R _g = 2.2kΩ, DIN/AUDIO	64	74		dB
Channel Balance	CB _P		-1.5	0	+1.5	dB

Rec Amp.

Fixed Gain	G _{V-R}		37.0	39.0	42.5	dB
Maximum Output Voltage	V _{Om-R}	THD = 3%	1.0	1.9		V
Total Harmonic Distortion	THD _R	Filter: 400Hz - 30kHz		0.1	0.17	%
Output Noise	V _{no-R}	R _g = 1kΩ, DIN/AUDIO		260	550	μV
Channel Crosstalk	CT _R	R _g = 1kΩ, DIN/AUDIO	50	57		dB
Channel Balance	CB _R		-1.5	0	+1.5	dB

ALC

ALC Start Voltage	V _S	R _{ext} = 5.6kΩ Dual Channel Input	0.75	0.9	1.37	V
ALC Range*	W _{ALC}	R _{ext} = 5.6kΩ Dual Channel Input	35	46		dB
ALC Channel Balance	CB _{-ALC}	R _{ext} = 5.6kΩ Dual Channel Input	-2	0.1	+2	dB

Mute

Rec-Amp. Attenuation	Att	R _{ext} = 5.6kΩ, Pin 11 = V _{CC}	40	49		dB
----------------------	-----	--	----	----	--	----

* ALC Range is measured as follows: The input is increased until the output increases by 3dB above that when ALC starts. ALC Range is the difference in input levels between ALC starts and V_O = +3dB up.

■ Application Circuit

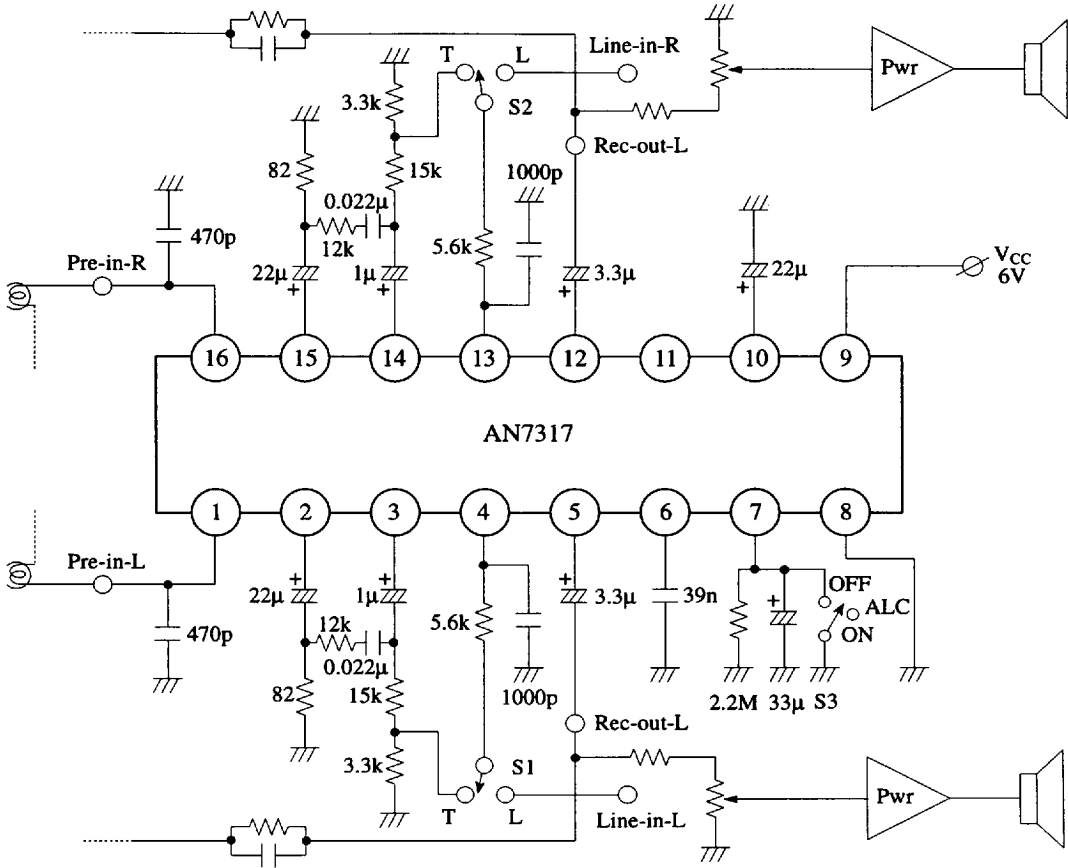

■ Application Notes

a) Gain Setting

Conditions:

- C2 . R1 = 3180µs
- C2 . R2 = 120µs

If R1 = 112kΩ, therefore
 C2 = 0.027µF
 R2 = 4.3kΩ

Check: $39.2\text{dB} = R2/R3$
 $R3 = 4.3\text{k}/91.2$
 $= 47\Omega$

Playback Amp.

Gain = 43.2dB (1kHz)

Rec Amp.

Gain = 39dB

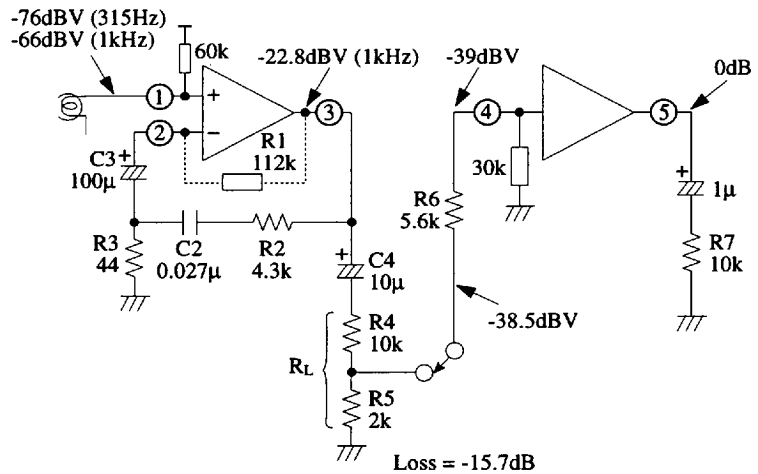

■ Application Notes (Continue)

a) Gain Setting

$$51.2\text{dB} = \frac{R2 + \frac{1}{j \cdot 2 \cdot \pi \cdot 315 \cdot C2}}{R3}$$

R3 = 52Ω (Use R3 = 47Ω)

$$\frac{1}{2 \cdot \pi \cdot C3 \cdot R3} < 20\text{Hz}$$

C3 = 169μF (Use C3 = 100μF)

$$\frac{1}{2 \cdot \pi \cdot C4 \cdot R_L} < 20\text{Hz}$$

$$C4 > \frac{1}{2 \cdot \pi \cdot 12000 \cdot 20}$$

C4 = 0.66μF (Use C4 = 0.47μF)

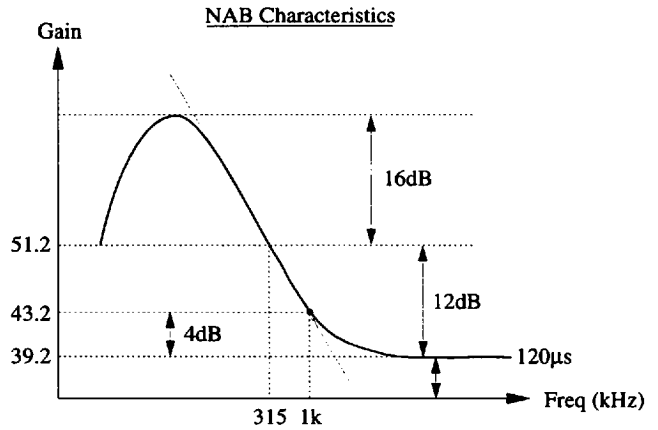

b) Input and Output Impedance of PB & Rec. Amps.

PB Amp.

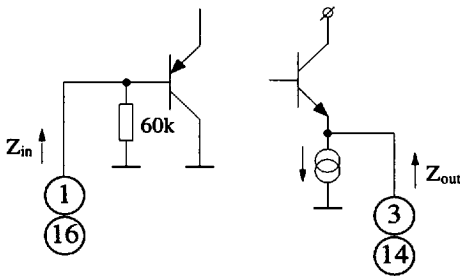

Z_{in} = 60kΩ (Theoretical)

Z_{in} = 53.7kΩ (Measured)

Z_{out} = r_e (Theoretical)

$$= \frac{V_T}{I_E}$$

$$= \frac{26\text{mV}}{1\text{mA}}$$

$$= 26\Omega$$

Z_{out} = 43.3Ω (Measured)

Rec Amp.

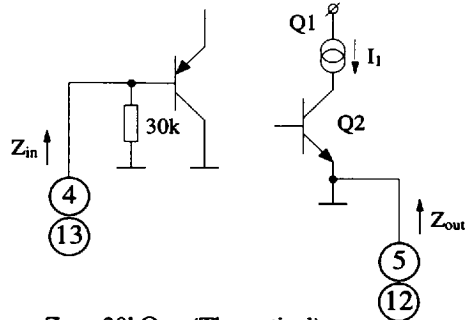

Z_{in} = 30kΩ (Theoretical)

Z_{in} = 26.5kΩ (Measured)

$$Z_{out} = \frac{V_{AP}}{I_C} // \frac{V_{AN}}{I_C} \text{ (Theoretical)}$$

$$= \frac{48.7}{23\text{m}} // \frac{104}{2.3\text{m}}$$

$$= 21\text{k} // 45\text{k}$$

$$= 14.3\text{k}\Omega$$

Z_{out} = 11.9kΩ (Measured)

The Rec-Amp. output is a collector to collector connection. Q1 sources current to, while Q2 sinks current from the load. Hence, the current capability of the Rec-Amp. output is important. Concept of low output impedance is relevant only to PB-Amp..

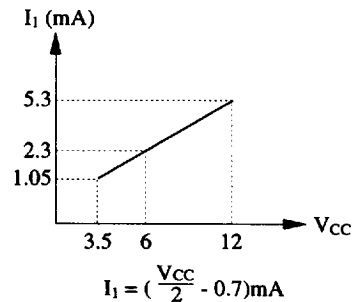

■ Application Notes (Continue)

c) ALC Attack & Recovery Time

ALC attack-time (t_A) is the time taken for ALC to become effective. t_A is measured from the onset of a high input signal to the point of time at which output settles to ALC level. On the other hand, ALC recovery-time (t_R) is the time taken for the ALC to become ineffective. t_R is measured from the instant of transition from a high to low level input signal, to the point of time at which the output amplitude becomes steady. For recovery-time, the designations 90% and 70% recovery are used to indicate respective percentage of the steady state output level.

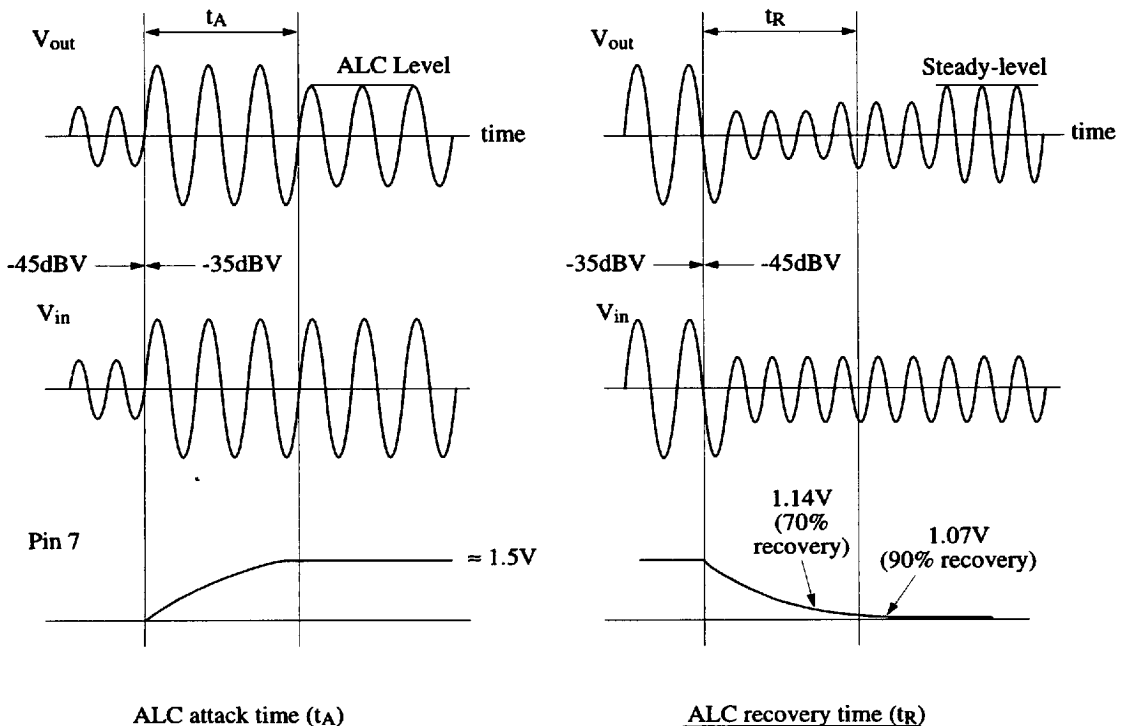

Theoretical estimates:

$$t_A = 5794 \times C7 \text{ (seconds)}$$

$$t_R = 0.0578 \times C7 \times R7 \text{ (70% recovery)}$$

$$0.1183 \times C7 \times R7 \text{ (90% recovery)}$$

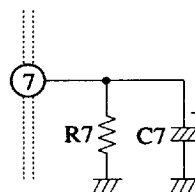

The attack-time is proportional to the value of C7. On the other hand, the recovery time depends proportionally on R7 x C7 constant.

■ Application Notes (Continue)

c) ALC Attack & Recovery Time

The following table shows the experimental results of t_A & t_R obtained from various combinations of R7 & C7:

C7	R7	t_A	t_R (70%)
5 μ	2.2M	20ms	0.4s
5 μ	3.3M	20ms	1.0s
5 μ	4.7M	20ms	1.1s
10 μ	2.2M	50ms	1.2s
10 μ	3.3M	50ms	2.5s
10 μ	4.7M	50ms	3.0s
22 μ	2.2M	125ms	2.8s
22 μ	3.3M	125ms	3.6s
22 μ	4.7M	125ms	3.75s
33 μ	2.2M	180ms	3.6s
33 μ	3.3M	225ms	4.0s
33 μ	4.7M	225ms	4.4s

← Recommended values

d) Additional Feature

Pop-noise, during power up is caused by transient noise at the PB amplifier outputs that passes into the REC amp. or power amp.. This defect can be solved by a good design involving timing considerations, that basically let the REC amplifier start up slower than the PB amplifier.

AN7317 solves this possible defect by including mute function. Typically, the REC amplifier inputs are muted for about 100ms upon power up, so that any transient noise is muted. Furthermore, the record-mute function can be activated at any time by shorting Pin 11 to V_{CC} .

