

2-channel reversible motor driver

BA6238A / BA6238AN / BA6239A / BA6239AN

The BA6238A, BA6238AN, BA6239A, and BA6239AN are monolithic ICs incorporating two reversible-motor drivers that are suitable for driving small DC brush motors.

The logic input section for controlling each motor can be easily connected with CMOSs and other control logic outputs. The torque during loading can be varied by controlling the voltage supplied to the motor with pin 8 of the output section. With a limited number of external parts, each driver has a function of two reversible-motor drivers.

●Applications

VCRs and audio tape recorders

●Features

- 1) Two reversible-motor driver circuits are built in. (not operable at the same time)
- 2) Limited number of external parts.
- 3) Interface with CMOS devices. (protective resistor required when the CMOS output is higher than 5V)
- 4) Built-in power transistor for motor driving.
- 5) Built-in thermal shutdown circuit. (the circuit brakes the output when the chip temperature is increased due to such an event as motor locking)

●Block diagram

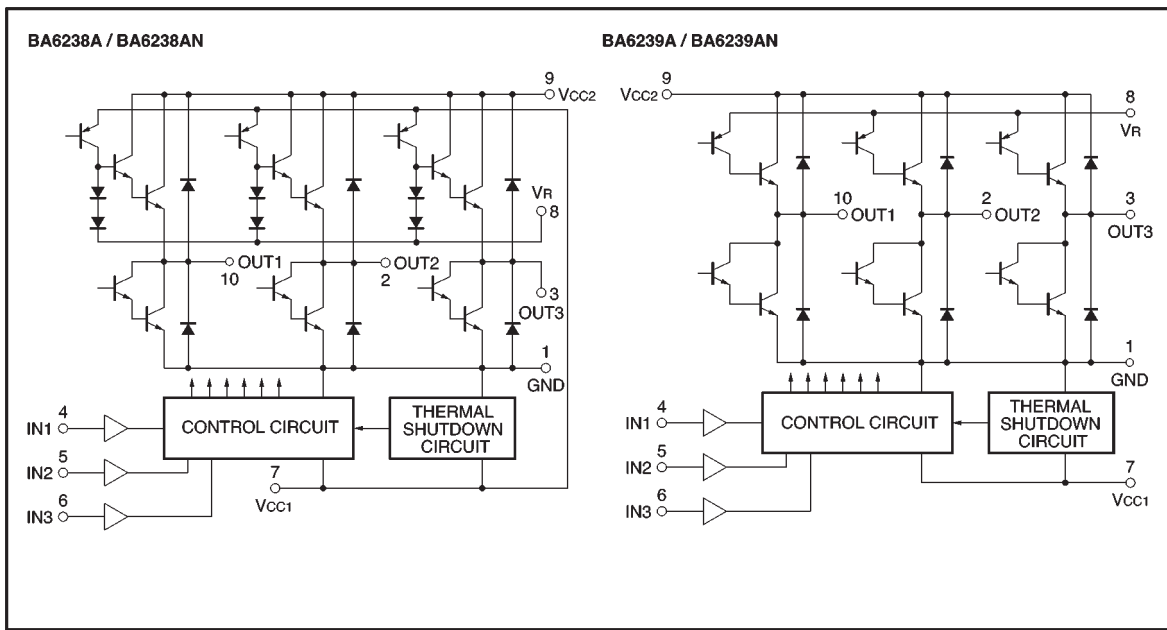

● Absolute maximum ratings (Ta = 25°C)

BA6238A / BA6238AN

Parameter		Symbol	Limits	Unit
Power supply voltage		V _{CC}	20	V
Power dissipation	BA6238A	Pd	2200*1	mW
	BA6238AN		1000*2	
Operating temperature		Topr	-25~+75	°C
Storage temperature		Tstg	-55~+125	°C
Input voltage		V _{IN}	-0.3~+5	V
Output current		I _{OUT}	1.6*3	A

*1 Refer to the power dissipation characteristics (Fig. 8) for details.

*2 Refer to the power dissipation characteristics (Fig. 9) for details.

*3 500 μs pulse with a duty ratio of 1%.

BA6239A / BA6239AN

Parameter		Symbol	Limits	Unit
Power supply voltage		V _{CC}	20	V
Power dissipation	BA6239A	Pd	2200*1	mW
	BA6239AN		1000*2	
Operating temperature		Topr	-25~+75	°C
Storage temperature		Tstg	-55~+125	°C
Input voltage		V _{IN}	-0.3~+5	V
Output current		I _{OUT}	1.2*3	A

*1 Refer to the power dissipation characteristics (Fig. 8) for details.

*2 Refer to the power dissipation characteristics (Fig. 9) for details.

*3 500 μs pulse with a duty ratio of 1%.

● Recommended operating conditions (Ta = 25°C)

BA6238A / 6238AN

Parameter	Symbol	Min.	Typ.	Max.	Unit
Power supply voltage	V _{CC1} V _{CC2}	8	—	18	V
Power supply voltage	V _R	0	—	18	V

BA6239A / 6239AN

Parameter	Symbol	Min.	Typ.	Max.	Unit
Power supply voltage	V _{CC1} V _{CC2}	8	—	18	V
Power supply voltage	V _R	8	—	18	V

●Electrical characteristics (unless otherwise noted, Ta = 25°C and V_{CC} = 12V)

BA6238A / BA6238AN

Parameter	Symbol	Min.	Typ.	Max.	Unit	Conditions	Measurement circuit
Supply current	I _{CC}	—	12	24	mA	R _L =∞ ; pin 4, 5, 6="L"	Fig.1
Input low level voltage of pins 4, 5, and 6	V _{IL}	—	—	1.0	V	—	Fig.1
Input high level voltage of pins 4, 5, and 6	V _{IH}	4.0	—	—	V	—	Fig.1
Output low level voltage of pins 2, 3, and 10	V _{OL}	—	0.8	1.5	V	Pin 8=open, I _O =0.5A	Fig.1
Output high level voltage of pins 2, 3, and 10	V _{OH}	10	10.5	—	V	Pin 8=open, I _O =0.5A	Fig.1
Output leakage current	I _{OL}	—	—	1	mA	Current flowing into pin 9 when pin 4, 5, 6 = LOW and R _L = ∞	Fig.1
Output offset voltage of pin 2	ΔV ₂	-0.5	—	0.5	V	V _R =6.0V In reference to pin 8, I _{O(2)} = 0.5 A	Fig.1
Output offset voltage of pin 3	ΔV ₃	-0.5	—	0.5	V	V _R =6.0V In reference to pin 8, I _{O(3)} = 0.5 A	Fig.1
Output offset voltage of pin 10	ΔV ₁₀	-0.5	—	0.5	V	V _R =6.0V In reference to pin 8, I _{O(10)} = 0.5 A	Fig.1
Pin 8 source current 1	I _{B(2)}	0.2	0.6	1.5	mA	Pin 2= "H", I _{O(2)} =0.5A V _R =6.0V	Fig.1
Pin 8 source current 2	I _{B(3)}	0.2	0.6	1.5	mA	Pin 3= "H", I _{O(3)} =0.5A V _R =6.0V	Fig.1
Pin 8 source current 3	I _{B(10)}	0.2	0.6	1.5	mA	Pin 10= "H", I _{O(10)} =0.5A V _R =6.0V	Fig.1
Backlash current	I _B	—	—	0.3	A	Pin 4, 5, 6 = LOW; current flowing into pin 9 when one of the output pins is -1 V	Fig.1
Thermal shutdown activation temperature	T _{ON}	—	150	—	°C	—	Fig.1
Thermal shutdown deactivation temperature	T _{OFF}	—	100	—	°C	—	Fig.1

BA6239A / BA6239AN

Parameter	Symbol	Min.	Typ.	Max.	Unit	Conditions	Measurement circuit
Supply current	I _{CC}	—	12	24	mA	R _L =∞ Pin 4, 5, 6="L"	Fig.2
Input low level voltage of pins 4, 5, and 6	V _{IL}	—	—	1.0	V	—	Fig.2
Input high level voltage of pins 4, 5, and 6	V _{IH}	4.0	—	—	V	—	Fig.2
Output low level voltage of pins 2, 3, and 10	V _{OL}	—	0.8	1.5	V	R _L =100Ω	Fig.2
Output high level voltage of pins 2, 3, and 10	V _{OH}	10.5	11.2	—	V	R _L =100Ω	Fig.2
Output leakage current	I _{OH}	—	—	1	mA	Current flowing into pin 9 when pin 4, 5, 6 = LOW . R _L =∞	Fig.2

● Measurement circuits

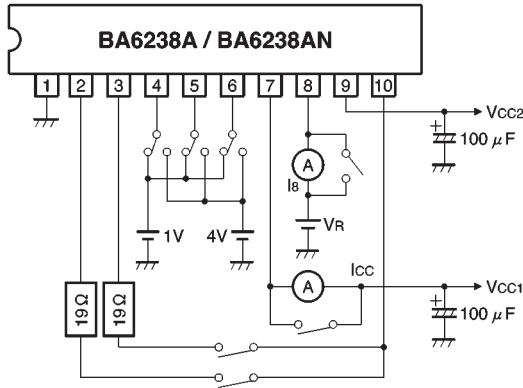

Fig.1

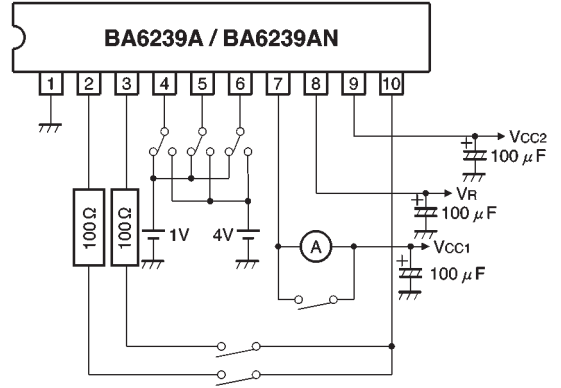

Fig.2

● Application examples

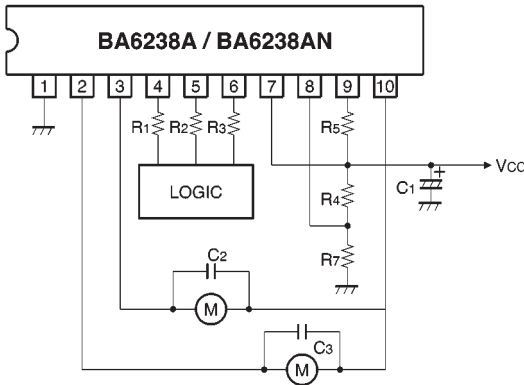

Fig.3

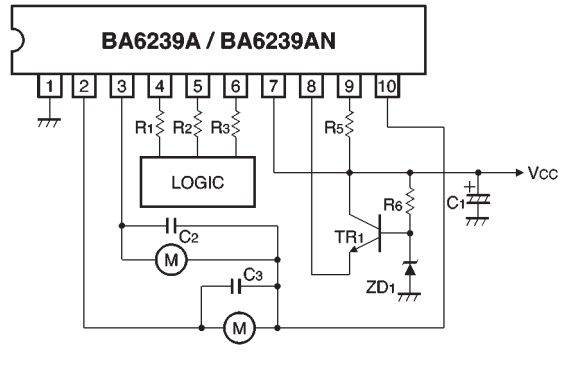

Fig.4

● Input / output truth table

Input			Output			Function
4pin	5pin	6pin	10pin	2pin	3pin	
L	L	X	L	L	L	Brake
H	L	L	H	L	OPEN	Current flow from pin 10 to pin 2
H	L	H	L	H	OPEN	Current flow from pin 2 to pin 10
L	H	L	H	OPEN	L	Current flow from pin 10 to pin 3
L	H	H	L	OPEN	H	Current flow from pin 3 to pin 10
H	H	X	L	L	L	Brake

X : Don't care

● Circuit operation

(1) Input (pins 4, 5, and 6)

These pins receive control logic signals. The relevant circuits are designed to have hysteresis and antinoise characteristics. The input circuit can control the logic by input currents of a few microamperes or more. The motor connected between pins 10 and 2 is selected when pin 4 is HIGH and pin 5 is LOW, while the motor connected between pins 10 and 3 is selected when pin 5 is HIGH and pin 4 is LOW. Pin 6 is the forward / reverse control input pin.

(2) Output (pins 2, 3, and 10)

Pin 10 is the common pin. Either pin 2 or 3 is left OPEN during motor driving. The waveform monitored on the OPEN pin will be the same as that on pin 10.

1) BA6238A / BA6238AN

The output stage configuration of the BA6238A / BA6238AN is shown in Fig. 5. The output stage contains NPN transistors in a Darlington configuration, which means the saturation voltage between V_{CC1} and the output pin is rather high but the output voltage can be easily set by using a zener diode or a resistor voltage divider. The voltage on the V_R pin can be varied from 0V to V_{CC1} . The output voltage is at the maximum when pin 8 is OPEN.

$$V_{OH} = V_{CC1} - V_{sat} \text{ (PNP)} - 2 \times V_{BE} \text{ (NPN Darlington)}$$

$$V_{OL} = V_{sat} \text{ (NPN Darlington)}$$

V_{sat} and V_{BE} are functions of the output current (see Fig. 17).

2) BA6239A / BA6239AN

The output configuration of the BA6239A / BA6239AN is shown in Fig. 6. Because the output stage contains only one NPN transistor, the saturation voltage between pin 8 and the output pin is about 0.7V less than that in the BA6238A. The output voltage is controlled by the pin-8 voltage. The voltage on the V_R pin can be varied from 8V to V_{CC1} . The output voltage is at the maximum when pin 8 is V_{CC1} .

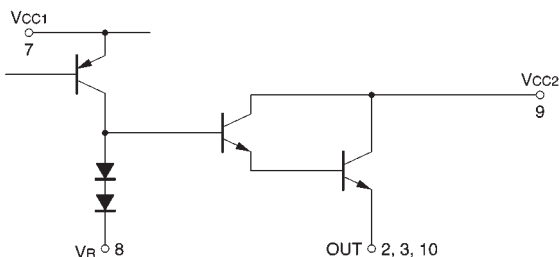

Fig.5

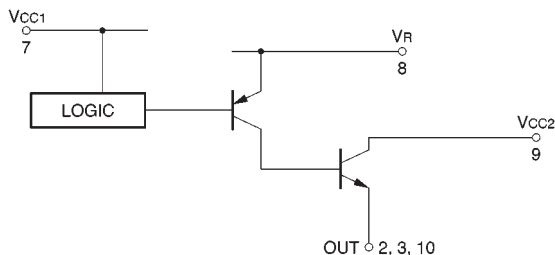

Fig.6

$$V_{OH} = V_R - V_{sat} \text{ (PNP)} - V_{BE} \text{ (NPN)}$$

$$V_{OL} = V_{sat} \text{ (NPN Darlington)}$$

V_{sat} and V_{BE} are functions of the output current (see Fig. 18).

(3) Output control (pin 8)

Output voltage can be varied by controlling the pin-8 voltage.

1) BA6238A / BA6238AN

The pin-8 voltage can vary from 0V to V_{CC} . Because a constant current (0.6mA typically) flows out from pin 8, the output voltage can be controlled by using a zener diode or a resistor voltage divider.

2) BA6239A / BA6239AN

In addition to controlling the output voltage, pin 8 supplies base current to the high-side output transistor (NPN).

(4) Power supply (pins 7 and 9)

Pin 7 supplies power to the input, logic, and thermal shutdown circuits. Pin 9 supplies power to the output transistors.

(5) Thermal shutdown circuit

Regardless of the input mode, the thermal shutdown circuit puts the outputs to LOW level when the chip temperature rises due to such an event as motor locking. When the thermal shutdown circuit is deactivated, the outputs revert to the status determined by input mode.

The thermal shutdown circuit is activated when the chip temperature exceeds 150°C (125°C minimally), and deactivated when the chip temperature drops to 100°C (125°C maximally). The minimum temperature difference between the activation and deactivation settings is 10°C.

(6) Ground pin and fins

Pin 1 and the fins have the minimum potential within the IC. The PCB design should ensure that the common impedance is kept as low as possible when a large current flows.

● Operation notes

(1) Though the IC input pins can be directly connected with MOS output pins, it is recommendable to connect resistors of about 3 ~ 30kΩ between the pins for the sake of pin protection (see Fig. 7).

(2) When reversing the rotational direction of a motor, make sure to go through the brake mode in-between the opposite directions. It is recommendable to keep the brake mode for at least 10μs.

(3) Powering procedures should be designed so that V_{CC1} (pin 7) always rises first and falls last.

(4) The quality of these products have been carefully checked; however, use of the products with applied voltages, operating temperatures, or other parameters that exceed the absolute maximum rating given may result in the damage of the IC and the product it is used in. If the IC is damaged, the short mode and open modes cannot be specified, so if the IC is to be used in applications where parameters may exceed the absolute maximum ratings, then be sure to incorporate fuses, or other physical safety measures.

(5) Input pins

Voltage should never be applied to the input pins when the V_{CC} voltage is not applied to the IC. Similarly, when V_{CC} is applied, the voltage on each input pin should be less than V_{CC} and within the guaranteed range for the electrical characteristics.

(6) Back-rush voltage

Depending on the ambient conditions, environment, or motor characteristics, the back-rush voltage may fluctuate. Be sure to confirm that the back-rush voltage will not adversely affect the operation of the IC.

(7) Large current line

Large currents are carried by the motor power supply and motor ground for these ICs.

Therefore, the layout of the pattern of the PC board and the constants of certain parameters for external components, such as the capacitor between the power supply and ground, may cause this large output current to flow back to the input pins, resulting in output oscillation or other malfunctions. To prevent this, make sure that the PC board layout and external circuit constants cause no problems with the characteristics of these ICs.

(8) Power dissipation

The power dissipation will fluctuate depending on the mounting conditions of the IC and the ambient environment. Make sure to carefully check the thermal design of the application where these ICs will be used.

(9) Power consumption

The power consumption by the IC varies widely with the power supply voltage and the output current. Give full consideration to the power dissipation rating and the thermal resistance data and transient thermal resistance data, to provide a thermal design so that none of the ratings for the IC are exceeded.

(10) ASO

Make sure that the output current and supply voltage do not exceed the ASO values.

(11) Precautions for input mode switching

To ensure reliability, it is recommended that the mode switching for the motor pass once through the open mode.

(12) Factors regarding the thermal, power supply, and motor conditions

If the potential of the output pin sways greatly and goes below the potential of ground, the operation of the IC may malfunction or be adversely affected. In such a case, place a diode between the output and ground, or other measure, to prevent this.

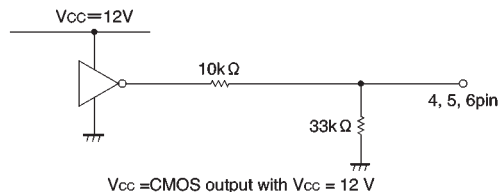

Fig.7

●Electrical characteristic curves

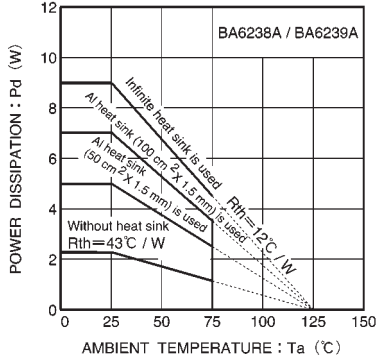

Fig.8 Power dissipation curves (BA6238A/BA6239A)

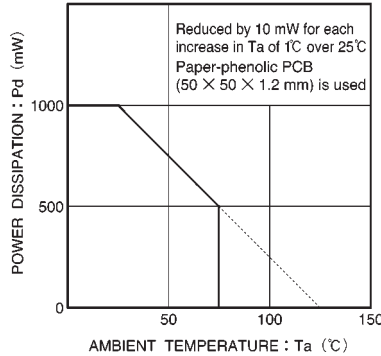

Fig.9 Power dissipation curve (BA6238AN/BA6239AN)

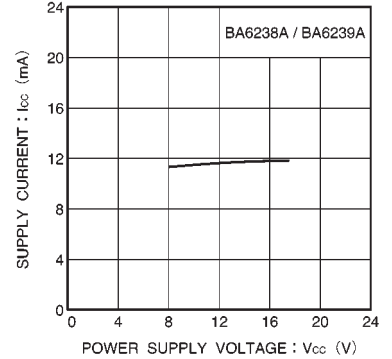

Fig.10 Supply current vs. power supply voltage

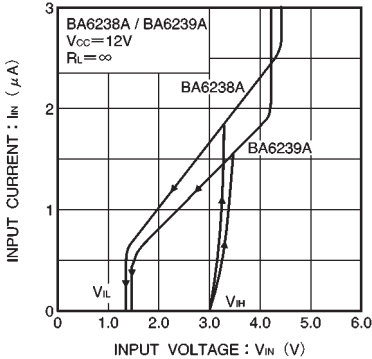

Fig.11 Input current vs. input voltage

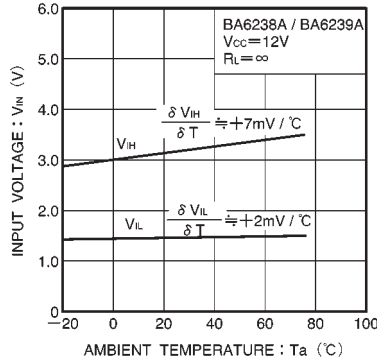

Fig.12 Input voltage vs. ambient temperature

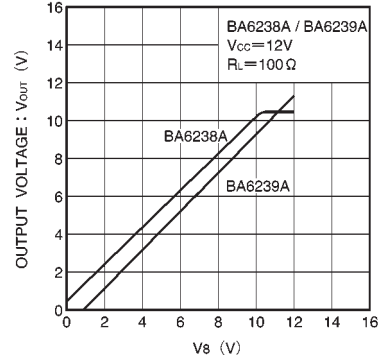

Fig.13 Output voltage vs. pin-8 voltage

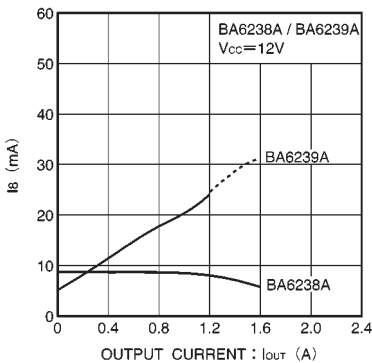

Fig.14 Pin-8 current vs. output current

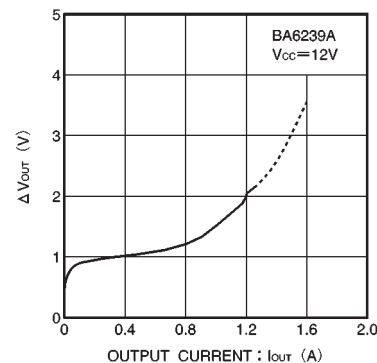

Fig.15 Output voltage variation vs. output current

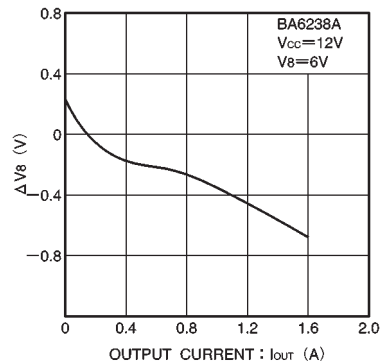

Fig.16 Pin-8 voltage variation vs. output current

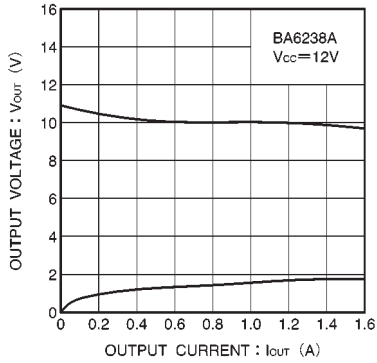

Fig.17 Output voltage vs. output current (BA6238A)

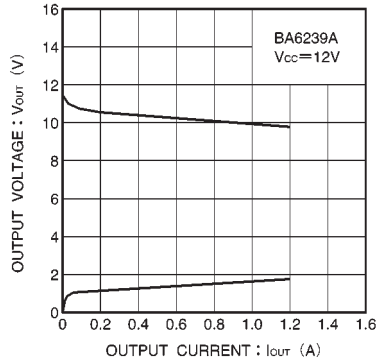
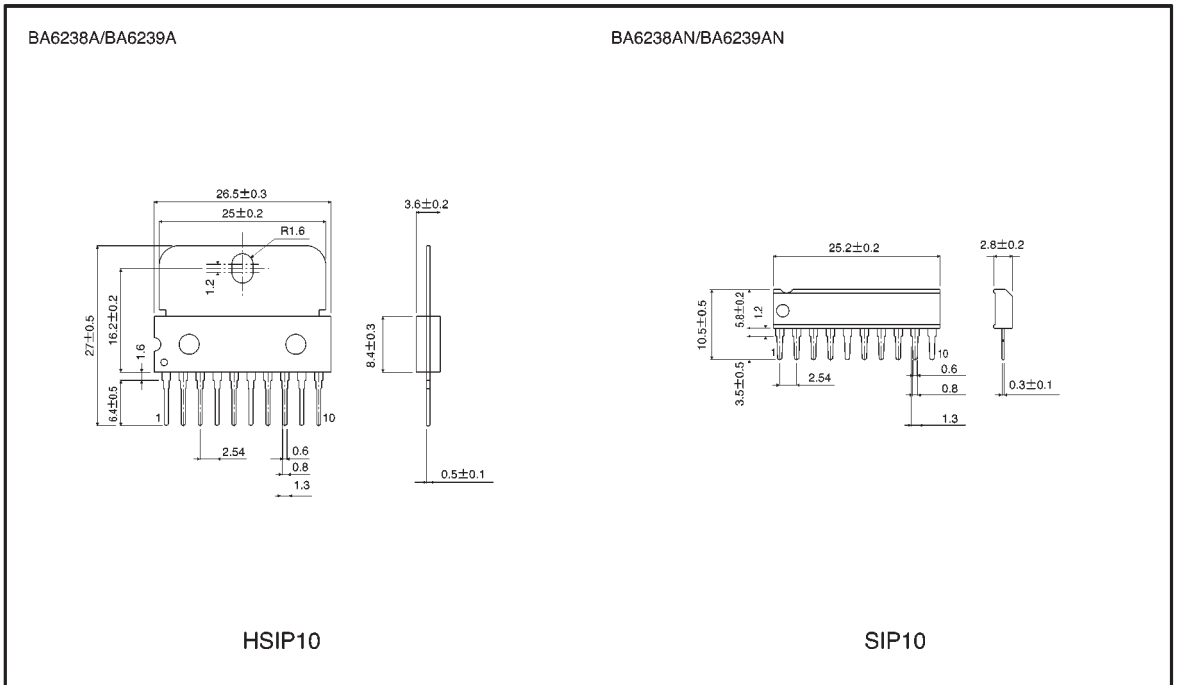

Fig.18 Output voltage vs. output current (BA6239A)

● External dimensions (Units: mm)



Notes

- No technical content pages of this document may be reproduced in any form or transmitted by any means without prior permission of ROHM CO.,LTD.
- The contents described herein are subject to change without notice. The specifications for the product described in this document are for reference only. Upon actual use, therefore, please request that specifications to be separately delivered.
- Application circuit diagrams and circuit constants contained herein are shown as examples of standard use and operation. Please pay careful attention to the peripheral conditions when designing circuits and deciding upon circuit constants in the set.
- Any data, including, but not limited to application circuit diagrams information, described herein are intended only as illustrations of such devices and not as the specifications for such devices. ROHM CO.,LTD. disclaims any warranty that any use of such devices shall be free from infringement of any third party's intellectual property rights or other proprietary rights, and further, assumes no liability of whatsoever nature in the event of any such infringement, or arising from or connected with or related to the use of such devices.
- Upon the sale of any such devices, other than for buyer's right to use such devices itself, resell or otherwise dispose of the same, no express or implied right or license to practice or commercially exploit any intellectual property rights or other proprietary rights owned or controlled by
- ROHM CO., LTD. is granted to any such buyer.
- Products listed in this document use silicon as a basic material.
Products listed in this document are no antiradiation design.

The products listed in this document are designed to be used with ordinary electronic equipment or devices (such as audio visual equipment, office-automation equipment, communications devices, electrical appliances and electronic toys).

Should you intend to use these products with equipment or devices which require an extremely high level of reliability and the malfunction of which would directly endanger human life (such as medical instruments, transportation equipment, aerospace machinery, nuclear-reactor controllers, fuel controllers and other safety devices), please be sure to consult with our sales representative in advance.

About Export Control Order in Japan

Products described herein are the objects of controlled goods in Annex 1 (Item 16) of Export Trade Control Order in Japan.

In case of export from Japan, please confirm if it applies to "objective" criteria or an "informed" (by MITI clause) on the basis of "catch all controls for Non-Proliferation of Weapons of Mass Destruction.