

HKS ELECTRONICS TECHNOLOGY

EVC-S

ELECTRONIC VALVE CONTROLLER *typeS*

Instruction Manual

NOTICE

This manual assumes that you have and know how to use the tools and equipment necessary to safely perform service operations on your vehicle. This manual assumes that you are familiar with typical automotive systems and basic service and repair procedures. Do not attempt to carry out the operations shown in this manual unless these assumptions are correct. Always have access to a factory repair manual. To avoid injury, follow the safety precautions contained in the factory repair manual.



E05121-K00121-00
2009.10.01
Ver. 3-1.01

INTRODUCTION

Read this instruction manual prior to installation to ensure safe and correct usage for optimal product performance.

PRODUCT	EVC-S
USE	Boost Pressure Controller for Turbocharged Automobile Engines
APPLICATION	DC12V Negative Ground Vehicles
PART No.	45003-AK009
REMARKS	<ul style="list-style-type: none">• A fuel controller (e.g. F-CON V Pro, F-CON iS, etc) may be required when using this product.• When installing this product on a twin turbocharged vehicle or a vehicle using a 4mm hose line, a separate Hose Set is required.• When the boost pressure is increased, the factory ECU may activate a fuel cut. To deactivate the fuel cut function, a unit such as the HKS FCD is required. When using an HKS FCD, a fuel controller must be used as additional fuel tuning.

The HKS EVC enables the adjustment of boost settings from inside the vehicles cabin area.

This product was developed to improve engine output and was designed to be used for racing on a closed circuit, where this unit is highly effective. When the engine output is improved, water and/or oil temperature may rise, and insufficient oil pressure may occur. Always monitor these vital readings to obtain optimal engine performance.

If using this product on a public road, follow all necessary laws, procedures and regulations for a tuned/modified vehicle.

● Compact Size / 4 Separate Units

EVC-S includes 4 separate units: Display Unit, Control Unit, Boost Sensor, and Solenoid Valve.

Each unit is compact and easy to install in the engine bay and the interior. Since the Boost Sensor is independent, hose routing does not need to run into the vehicles interior.

● Capable of Controlling High Boost

EVC-S can control up to 250kPa (36PSI)

● Simple Boost Setting

Directly input the desired boost value to modes A and B, and let the HKS EVC control the boost.

● Return Function

The boost setting returns to the factory setting when the power is turned off. On some vehicles, the boost value may be lower than the boost before installing the EVC-S.

● 2 Mode Boost Setting Function

A Mode and B Mode allow for 2 different boost settings.

● **Warning Function**

If the boost level exceeds the warning value, the unit will warn the user with an audible buzzer and visually on the display. The boost value will be lowered to the set value. This function protects the engine and turbocharger from excessive boost.

● **After Image Display Function**

When the boost changes from positive pressure to negative pressure, the maximum boost under positive pressure can be displayed for 3 seconds. This function can be turned off.

● **Data Memory Function**

Each setting value is saved in the internal memory; the saved values are retrievable even after the ignition is shut-off or the battery is disconnected.

● **Exhaust Bypass Select Function**

Can be used as swing valve type (internal wastegate/actuator) or poppet valve type (external wastegate) for a large capacity turbocharger.

● **Boost Unit of Measure Select Function**

The boost unit of measure is selectable between kPa and PSI.

● **Data Lock Function**

The setting data can be protected by a password to prevent unwanted or accidental changes.

- This manual indicates items you need to pay attention to in order to install this product safely and lists precautions to avoid any possible damage and/or accidents.
- For any missing, defective and/or damaged parts, contact your Authorized HKS Dealer.
- This product was developed for racing use. To use this product on public roads, follow the necessary laws, procedures and regulations for a tuned/modified vehicle.
- HKS will not be responsible for any damage caused by incorrect installation and/or use or use after modification and/or dismantling of this product.
- This product was designed based on installing it onto a factory vehicle or a vehicle using other HKS products. The performance and/or safety cannot be guaranteed if this product was installed onto other inapplicable vehicles.
- This product works only on vehicles with a DC12V negative ground.
- The specifications of this product are subject to be changed without notice.
- This manual is subject to be revised without notice.
- This manual must be given to the end user after installation is complete.

INDEX

INTRODUCTION	1
INDEX	3
SAFETY PRECAUTION	4
PARTS LIST	6
NAMES & FUNCTIONS	7
INSTALLATION	8
CONFIRMATION AFTER INSTALLATION	19
OPERATION	20
OPTIONAL PARTS LIST	33
MAINTENANCE	33
TROUBLESHOOTING	34
REPAIR SERVICE	35
FOR SUBSEQUENT OWNERS	36
PRODUCT SPECIFICATIONS	36
INSTRUCTION MANUAL REVISION RECORD	37

SAFETY PRECAUTION



WARNING

- Make sure to work on the vehicle in a well-ventilated area to prevent possible explosion or fires.
- To avoid possible accidents, do not mount the unit in areas where the driver may become distracted during driving or the product cannot be mounted securely.
- Do not install this product on a 24V vehicle. It may cause a fire.
- Make sure to disconnect the negative cable from the battery to avoid possible damage to other electronic parts and/or a fire caused by a short circuit.
- Make sure to hold and remove wire connectors properly to avoid possible damage to other electronic parts and/or a fire caused by disconnection or a short circuit.
- Stop using this product if any unusual problems should occur. Consult your Authorized HKS Dealer immediately.
- Do not operate this product while driving to avoid possible accidents.



CAUTION

- Do not install this product by yourself unless you have and know how to use the tools and equipment necessary to safely perform service operations on your vehicle.
- Do not modify, disassemble, and/or repair this product and supplied parts to avoid any damage to the unit and/or wiring harness. This will also void the warranty.
- Handle parts with extra care at all times.
- Avoid allowing oil and/or water from entering the unit. It may damage the unit and cause damage to the engine.
- Prior to installation, make sure the engine bay temperature has cooled down. Failure to let the engine cool can lead to severe burns.
- Select the appropriate exhaust bypass type. Selecting the wrong type may cause damage to the engine.
- To avoid possible malfunction and damage to the engine, install the unit away from areas of excessive heat or water/moisture.
- Do not tie or bundle any hoses or harnesses to any vehicle fuel lines. It may cause a fire or severe damage to the vehicle.
- Make sure all connections and wiring are correct and do not become shorted or disconnected. If so, it may cause an electric shock or damage the vehicle.
- Use the provided crimp connectors and install them in the correct positions. If not, it may cause serious damage to the vehicle.









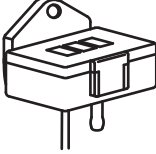
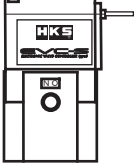

CAUTION

- Connect the ground wire to a good chassis ground. If not, it may cause damage to the vehicle.
- Insert the vacuum filter and replace it at regular intervals. If not, it may cause damage to the vehicle.
- When installing the vacuum filter, make sure no oil or lubricants exist causing the hose to come off. If a hose comes off, it may cause damage to the vehicle.
- Replace the vacuum filter more frequently if there is excessive dirt build-up. Dirt build up may cause an inability to control boost, which may cause damage to the engine.
- Do not raise the boost pressure excessively. It may cause damage to the engine and turbocharger.
- Activate the Warning Function of this product to prevent damage to the engine caused by excessive boost pressure.
- Do not test this product on public roads.
- If this product or the vehicle with this product installed does not operate properly, consult your retailer/dealer immediately.
- Do not try to repair this product by yourself.
- If any unusual noises, scents, and/or vibration are noticed, consult your Authorized HKS Dealer immediately.
- If this product is removed, make sure all wires from the vehicle are insulated to prevent damage to other electrical parts.

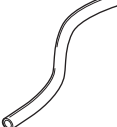
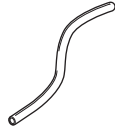
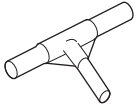
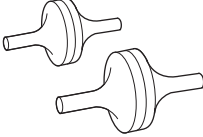
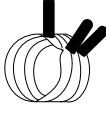
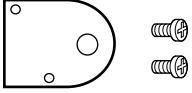
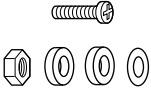
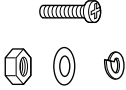
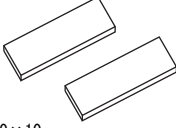
- Daily vehicle maintenance is the responsibility of the owner.
- This manual shows a typical installation. Actual installation may vary depending on the vehicle application.
- When removing the factory parts, refer to the factory manual.
- Make sure all connections and wiring are correct.
- Make sure to keep all removed factory parts.
- Make sure to use the appropriate tools when tightening nuts and bolts. Do not over-tighten.
- Make sure not to disconnect any of the vehicle's wiring when installing this product.
- For vehicles equipped with a boost pressure control solenoid valve, disconnect the hoses and/or connector to deactivate this function.

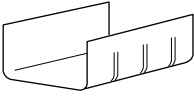
PARTS LIST

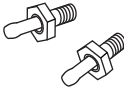
							
1	Display unit	2	Control Unit	3	Boost Sensor	4	Solenoid Valve
	1		1		1		1
							
	1.2m		2.5m				1 m
5	Power Supply Harness	6	Valve Extension Harness	7	6mm Hose	8	4mm Hose
	1		1	1801-SA004	1	1801-SA033	1
							
	φ4-4-4		4mm & 6mm		6mm		Bracket x 1 M4 Bolt x 2
9	T-fitting	10	Vacuum Filter	11	Hose Clamp	12	Valve Bracket Set
	1	6mm: 4599-RA016 4mm: 4599-RA017	1 Set		2		1 Set
							
	M6 Bolt · Nut x 1 M6 Flat Washer x 1 M6 Rubber Washer x 2		M6 Bolt · Nut x 1 M6 Flat Washer x 1 M6 Lock Washer x 1		60 × 10mm		100mm
13	Valve Install Hardware	14	Boost Sensor Install Hardware	15	Double-sided Tape	16	Tie Wrap
	1 Set		1 Set		2		5
							
17	Crimp Connector	18	Instruction Manual	19	Fitting		
	1		1		2		

● Keep unused parts.

● The following tools are required for installation: voltage meter, 10mm socket with ratchet, 10mm wrench 12mm wrench, phillips screwdriver, wire cutters, crimping tool and pliers.

NAMES & FUNCTIONS

Display Unit

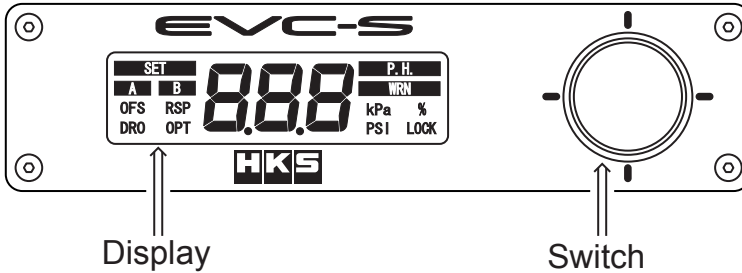

● Switch

Use this switch to select functions and settings. This switch can be pressed in 5 directions: up, down, left, right, and center. Each direction has 2 selectable options based on the duration of switch depression. In total, there are 10 ways of selecting functions and/or settings.

● Display

8.8.8

SET

Boost pressure or setting value is displayed.

This sign appears when editing the setting value under the Boost Setting Mode or Function Setting Mode.

A

This sign appears when the Boost Control Mode is activated with the A Mode setting value, or when editing the A Mode setting under the Boost Setting Mode. This sign does not appear under the Control Off Mode.

B

This sign appears when the Boost Control Mode is activated with the B Mode setting value, or when editing the B Mode setting under the Boost Setting Mode. This sign does not appear under the Control Off Mode.

OFS

This sign appears when setting the Off Set Value under the Boost Setting Mode.

RSP

This sign appears when setting the Response Value under the Boost Setting Mode.

DRO

This sign appears when setting the Drop Value under the Boost Setting Mode.

OPT

This sign appears when setting the Over Boost Value under the Boost Setting Mode.

P. H.

This sign appears when displaying the Peak Hold Value of the Boost value under the Boost Control Mode.

WRN

This sign appears when the Warning function is being activated.

kPa

This sign appears when "kPa" is selected as the unit of boost value.

PSI

This sign appears when "PSI" is selected as the unit of boost value.

%

This sign appears when setting the Off Set Value, Response Value or Drop Value under the Boost Setting Mode.

LOCK

This sign appears when setting the Data Lock, or trying to edit locked data.

For more details, refer to "Operation."

INSTALLATION

1. Removal of the Battery Cable	8
2. Hose Connection Layout	
2-1. Connecting the Boost Sensor	9
2-2. Connecting the Solenoid Valve	10
2-3. Connection of a Swing Valve Type	11
2-4. Connection of a Poppet Valve Type	15
3. Wiring	17
4. Mounting the Components	18
5. After Installation	19



WARNING

● Do not install this product on a 24V vehicle. It may cause a fire.

● This manual shows a typical installation. Actual installation may vary depending on the vehicle application.

1. Removal of the Battery Cable

(1) Disconnect the negative cable from the battery.

2. Hose Connection Layout

(1) Considering the hose and harness lengths, determine the appropriate mounting layout of the Display Unit, Control Unit, Boost Sensor, and Solenoid Valve.

ADVICE

- ※ Leave some slack for the harnesses and hoses to avoid tension during engine movement.
- ※ Do not install any components in high temperature areas.

2-1. Connecting the Boost Sensor

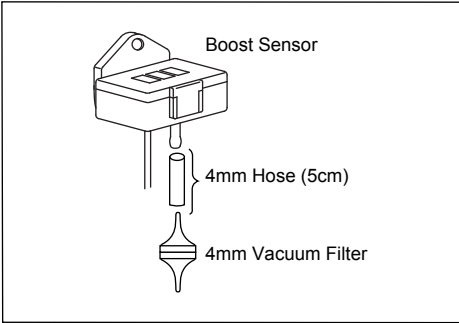

- (1) Cut the 4mm Hose to 5cm in length and connect the cut hose to the 4mm Vacuum Filter as illustrated in the diagram.

NOTE

- Remove any oil and/or lubricants on or in the hose and Vacuum filter.

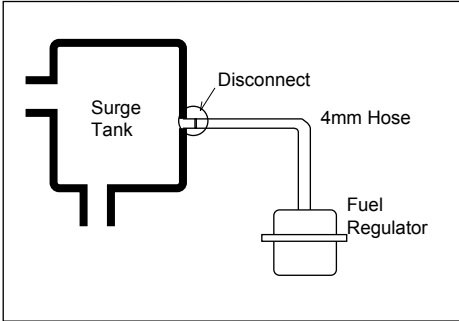

- (2) Disconnect the 4mm Hose between the fuel regulator and surge tank from the surge tank side.

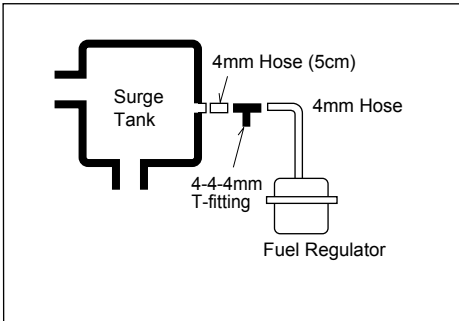

- (3) Cut the 4mm Hose to 5cm in length and insert the T-fitting as illustrated in the diagram.

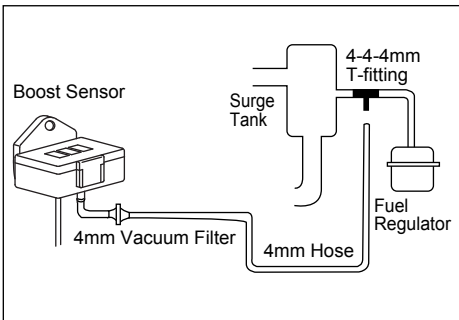

- (4) Connect the T-fitting and 4mm Vacuum Filter using the remaining 4mm Hose as illustrated in the diagram.

NOTE

- Keep the 4mm Hose to a minimum length.
- Remove any oil and/or lubricants on or in the hose and vacuum filter.
- Face the Boost Sensor's fitting downward to prevent any oil and/or water from entering the sensor.

2-2. Connecting the Solenoid Valve

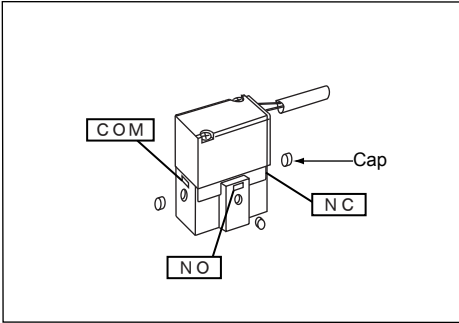

- (1) Remove the caps on the COM terminal, NO terminal, and NC terminal.

Swing Valve Type

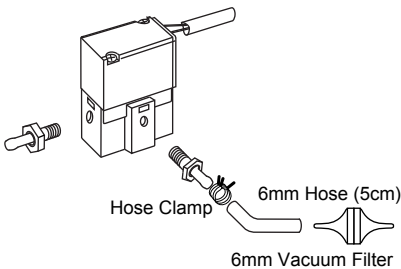

Swing Valve Type

- (2) Install the Fittings to the COM terminal and NO terminal.
- (3) Cut the 6mm Hose to 5cm in length, and connect the cut hose to the Fitting on the NO terminal and the 6mm Vacuum Filter.

NOTE

- Use a hose clamp to connect the hose to the fitting.
- Remove any oil and/or lubricants on or in the hose and vacuum filter.

Poppet Valve Type

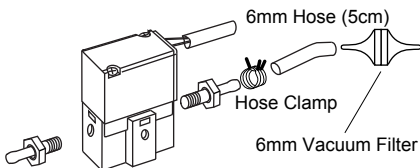

Poppet Valve Type

- (2) Install the Fittings to the COM terminal and NC terminal.
- (3) Cut the 6mm Hose to 5cm in length, and connect the cut hose to the 6mm Vacuum Filter.

NOTE

- Use a hose clamp to connect the hose to the fitting.
 - Remove any oil and/or lubricants on or in the hose and vacuum filter.
- (4) Refer to 2-4 to connect to the vehicle.

2-3. Installing the Boost Sensor and Solenoid Valve to Swing Valve Type

2-3.1 For Applications without a Boost Pressure Control Solenoid Valve

Before Installation (Factory Connection Layout)

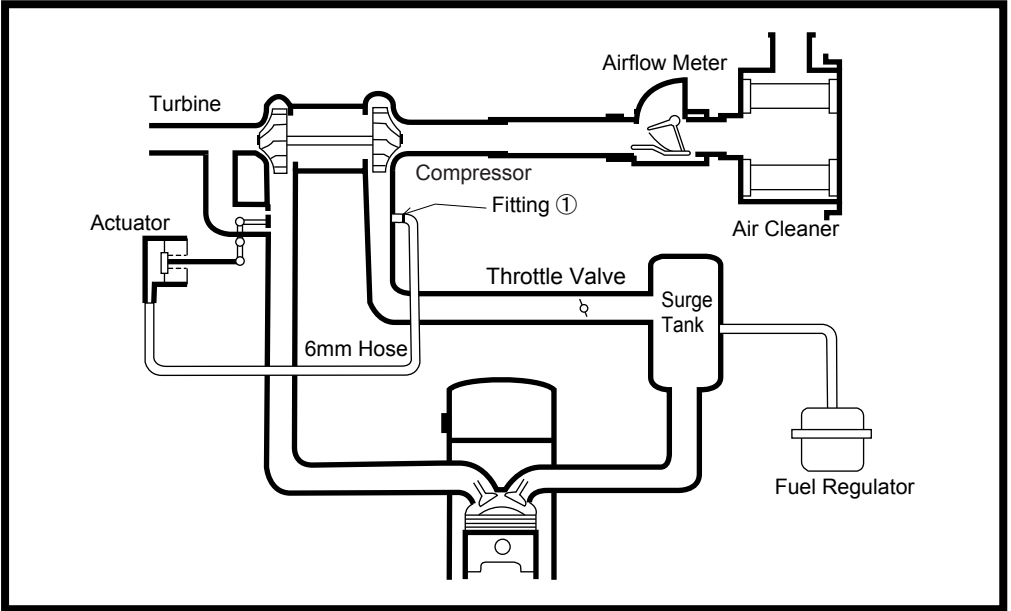

After Installation

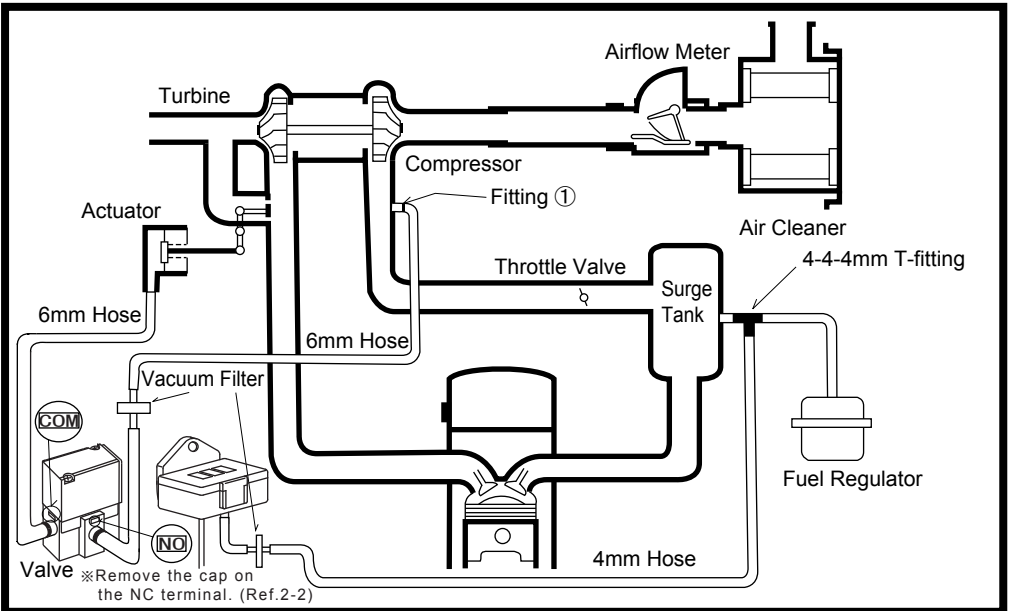

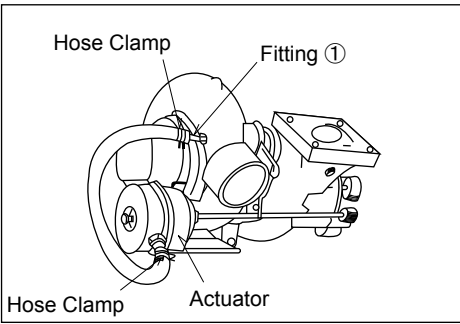

(1) Disconnect the hose connected to the actuator from fitting ① on the compressor side.

NOTE

- The position on the compressor side fitting ① may vary depending on the vehicle.
- Keep the removed factory hose clamp for later use.

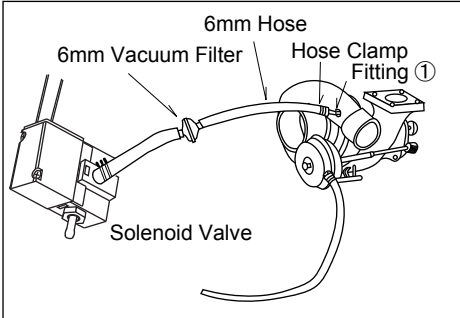

(2) Connect the provided 6mm Hose to fitting ① and the 6mm Vacuum Filter on the NO terminal of the Solenoid Valve.

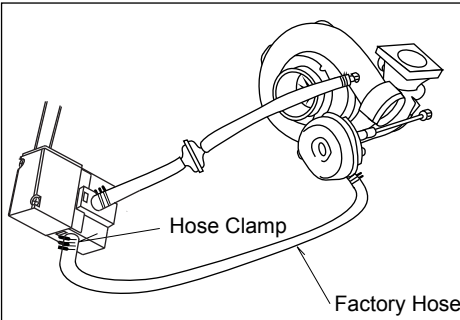

(3) Connect the factory hose from the actuator to the fitting on the COM terminal of the Solenoid Valve.

NOTE

- Remove any oil and/or lubricants on or in the hose and vacuum filter.
- Use hose clamps when connecting the 6mm Hose to the 6mm fittings.
- Depending on the vehicle, the factory hose may not be long enough to connect from the actuator to the Solenoid Valve. If so, additional 6mm Hose can be purchased as an optional part.

2-3.2 For Applications with a Boost Pressure Control Solenoid Valve 1

- For vehicles equipped with a boost pressure control solenoid valve, disconnect the connector and hose to deactivate this function.

Before Installation (Factory Connection Layout)

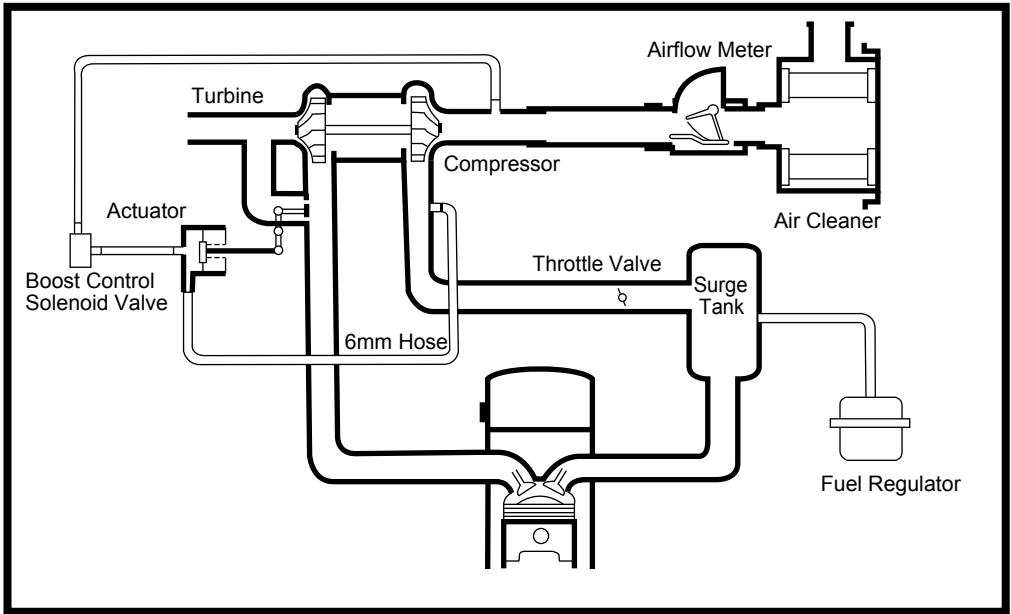

After Installation

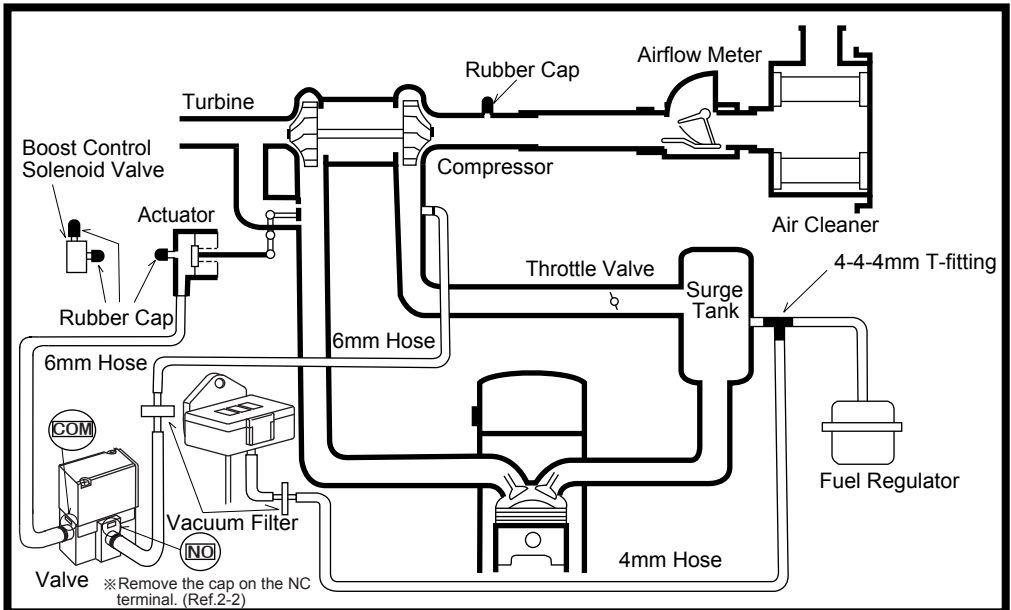

2-3.3 For Applications with a Boost Pressure Control Solenoid Valve 2

- For vehicles equipped with a boost pressure control solenoid valve, disconnect the connector and hose to deactivate the function.

Before Installation (Factory Connection Layout)

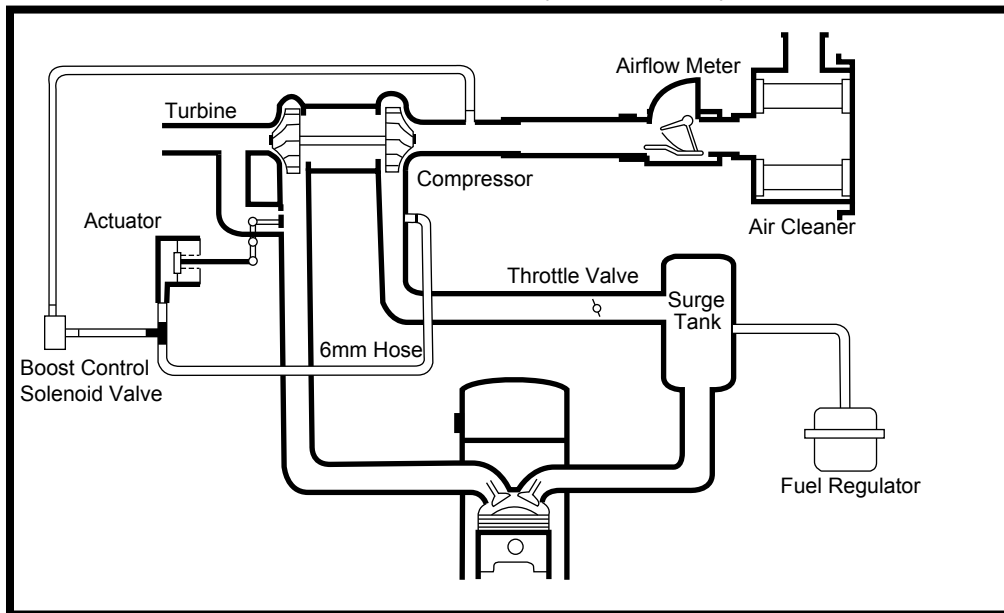

After Installation

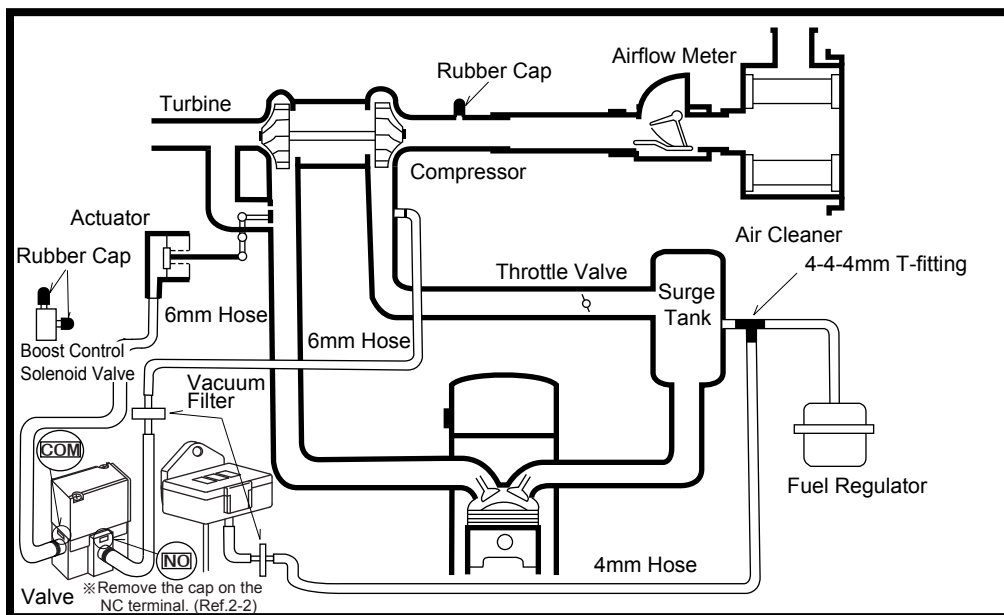

2-4. Installing the Boost Sensor and Solenoid Valve to Poppet Valve Type

A Poppet Valve Hose Set is required for this installation and is available separately.

Before Installation

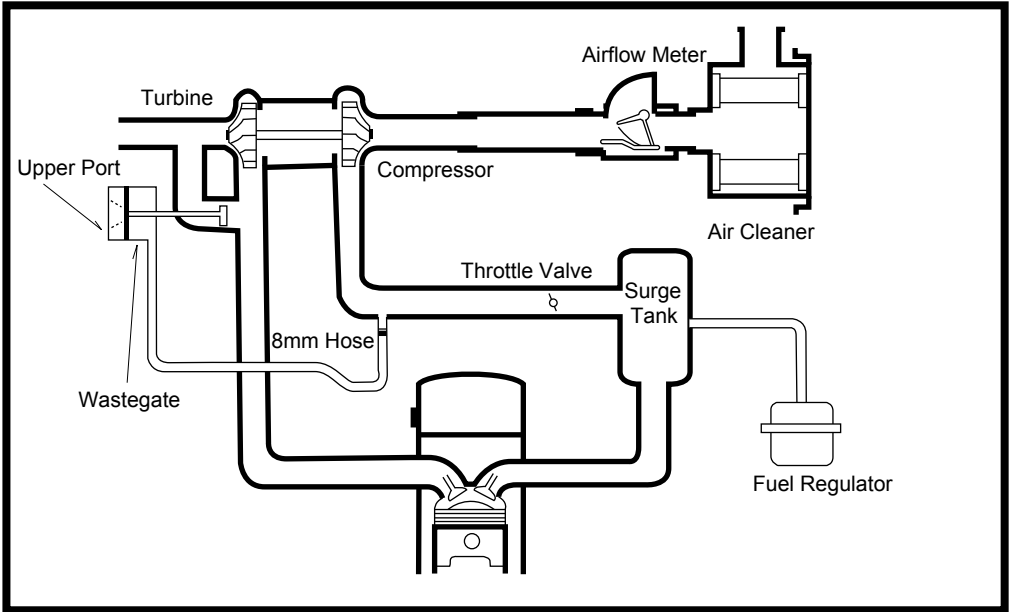

After Installation

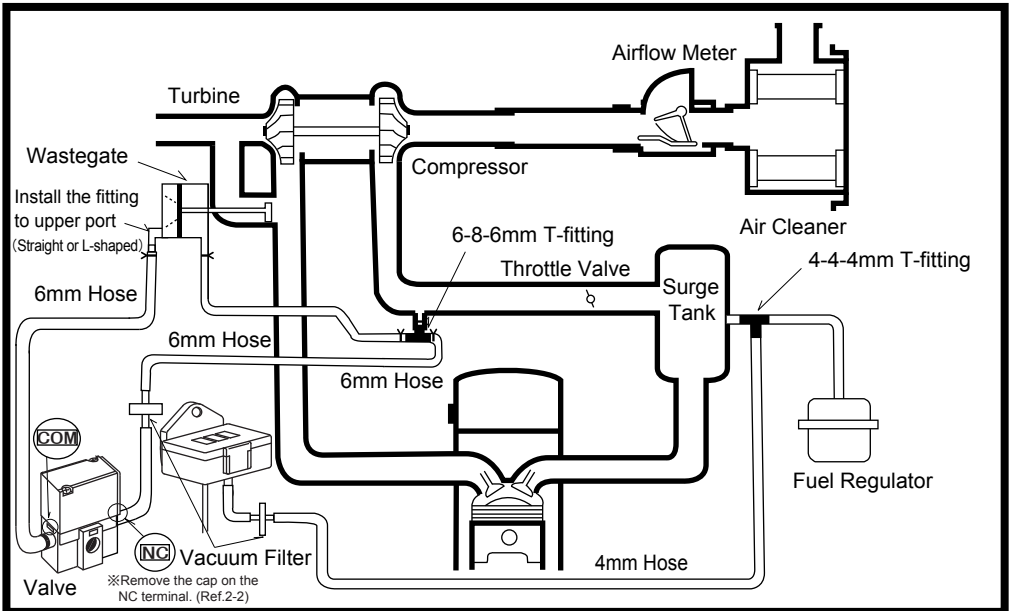

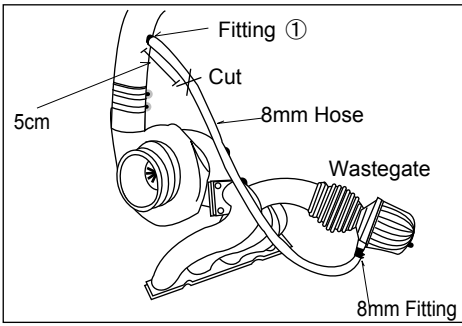

- (1) Cut the 8mm hose 5cm from the compressor's fitting ①. Remove the remaining 8mm hose and 8mm fitting from the wastegate.

NOTE

※The position of the fitting① on the compressor may vary depending on the vehicle.

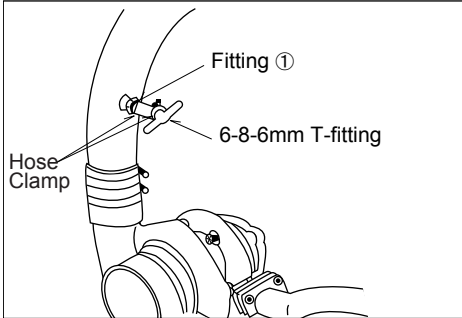

- (2) Install the 6-8-6mm T-fitting using the 8mm Hose Clamp.

NOTE

※Use the 6-8-6mm T-fitting and 8mm Hose Clamp included in the Poppet Valve Hose Set.

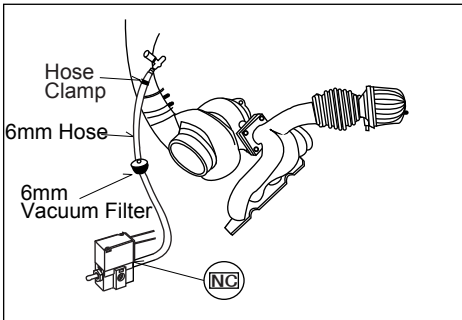

- (3) Connect the T-fitting with the 6mm vacuum filter to the NC terminal fitting using the 6mm hose from the Poppet Valve Hose Set.

ADVICE

※Remove any oil and/or lubricants on or in the hose and vacuum filter.

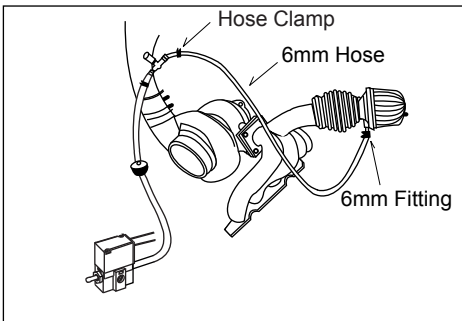

- (4) Remove the 8mm fitting from the wastegate, and install the 6mm fitting (straight or L-shaped) included in the Poppet Valve Hose Set.

- (5) Connect the T-fitting to the wastegate using the provided 6mm hose.

NOTE

※Use hose clamps when connecting hoses to fittings.

3. Wiring

3-1. Installing the Crimp Connectors

- ① Strip about 5mm of wire insulation.
- ② Connect another wire to the uncovered portion by twisting the wires together.
- ③ Crimp the twisted wires using a crimp connector.
- ④ Cover the crimp connector and wires with electrical tape to insulate.

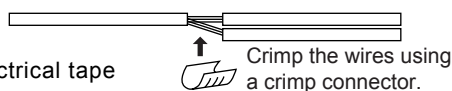
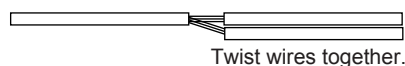
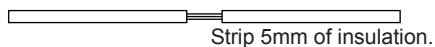

3-2. Wiring

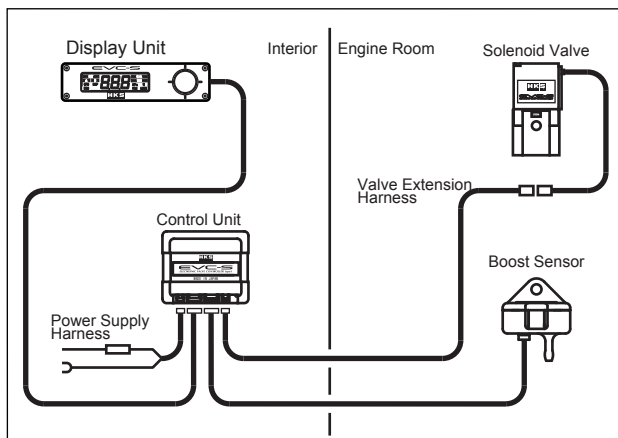

- (1) Connect the Solenoid Valve to the Valve Extension Harness. Pull the Valve Extension Harness and the harness connected to the Boost Sensor from the engine compartment into the vehicle's interior.
- (2) Connect the Valve Extension Harness and the Boost Sensor to the Control Unit.
- (3) Connect the Display Unit to the Control Unit.
- (4) Connect the Power Supply Harness.

Connect the red wire of the Power Supply Harness to a 12V IG (Ignition) using a crimp connector.

- a) Reconnect the negative cable to the battery.
- b) Turn the ignition on to find the 12V IG wire using a voltage meter.
- c) Disconnect the negative cable from the battery. Connect the ground wire to a good chassis ground.

NOTE

Remove any paint and/or rust from the surface where the ground wire is connected.

- (5) Connect the Power Supply Harness to the Control Unit.

4. Mounting Components

4-1. Mounting the Display Unit

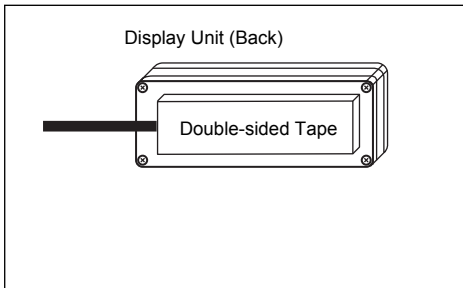

- (1) Remove any dirt, dust and/or oil from the mounting surface for the Display Unit.
- (2) Mount the Display Unit using the double-sided tape.

NOTE

Mount the Display Unit in a position lower than eye level, or tilted downward for best visibility.

4-2. Mounting the Solenoid Valve

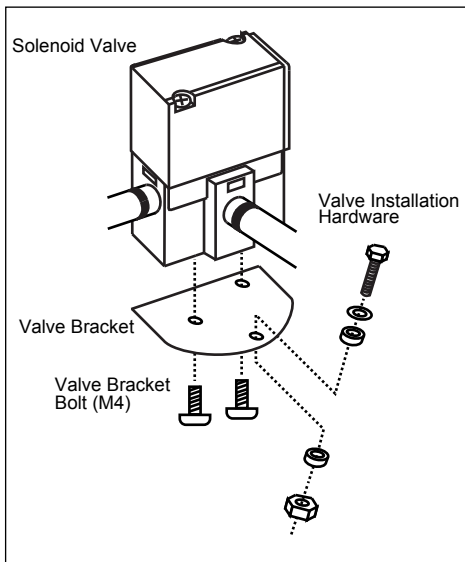

- (1) Install the Valve Bracket to the Solenoid Valve using the M4 bolts from the Valve Bracket Set.
- (2) Secure the Valve Bracket and the Solenoid Valve to the vehicle using the Valve Installation Hardware.

CAUTION

Install the Solenoid Valve away from excessive heat or water/moisture to avoid damage to the valve.

4-3. Mounting the Boost Sensor

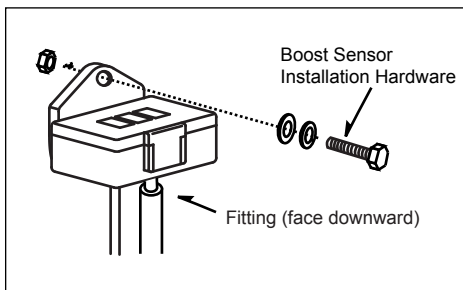

- (1) Secure the Boost Sensor to the vehicle using the Boost Sensor Installation Hardware.
- (2) When securing the Boost Sensor, make sure the fitting faces downward as shown in the diagram.

4-4. Securing Hoses and Harnesses

(1) Secure hoses and harnesses using the provided Tie Wraps.

NOTE

※Leave some slack for the harnesses and hoses to avoid tension during engine movement.

5. After Installation

(1) Reinstall all removed factory parts.

(2) Reconnect the negative cable to the battery.

CONFIRMATION AFTER INSTALLATION

Check the following after the installation process is complete:

1. Check the following after the installation process is complete:

ITEMS TO CHECK	CHECK
Make sure hoses are routed and connected correctly.	
Make sure hoses are not loosened.	
Make sure hoses are not damaged.	
Make sure hose clamps are tightened.	
Make sure all bolts and nuts are tightened securely.	
Make sure all installed components do not come in contact with any other parts.	
Make sure all installed parts are properly secured.	
Make sure wiring is done correctly.	
Make sure crimp connectors are connected securely.	
Make sure proper crimp connectors are used and crimped securely.	
Make sure the installed parts are mounted securely and do not interfere with driving.	
Make sure the negative cable terminal is securely attached to the battery.	
Make sure the boost pressure control solenoid valve is deactivated.	

2. Start the engine and check the following:

NOTE

※Do not raise the engine RPM right after the engine is started. (Let it idle.)

ITEMS TO CHECK	CHECK
Make sure air is not leaking.	
Make sure the RPM rises smoothly after revving the engine 2-3 times while in neutral.	
Make sure the installed parts do not come in contact with any other parts.	
Make sure there is no excessive stress on hoses and/or harnesses.	
Make sure all installed parts have not loosened after stopping the engine.	

OPERATION

1. Modes & Display Descriptions	21
2. Operation Outline	23
3. Boost Control Mode	25
3-1. Boost Control	
3-2. Boost Display	
3-2.1 Display on the Monitor	
3-2.2 Peak Hold Display	
3-2.3 After Image Display	
3-3. Warning Function	
4. Control Off Mode	26
5. Boost Setting Mode	27
5-1. Off Set Setting	
5-2. Response Setting	
5-3. Over Boost Setting	
5-4. Warning Boost Setting	
5-5. Drop Boost Setting	
6. Function Setting Mode	29
6-1. Unit Setting	
6-2. After Image Setting	
6-3. Data Lock	
6-4. All Data Reset	
7. Error Display	32

1. Modes & Display Description

1-1. Boost Control Mode

This mode controls the boost pressure and starts once the ignition is turned on. If the unit was previously in the Control Off Mode, it will remain in that mode when the ignition is initially turned on. The Boost Control Mode has an A Mode and B Mode which allows for 2 different boost settings. Input values for each of the following modes to maximize the vehicles boost curve.

- Off Set Value Setting Range: 0 - 100%. Default Setting: 10%.
As the percentage increases, the boost value increases.
As the percentage decreases, the boost value decreases.
- Response Value Setting Range: 0-100%. Default Setting: 20%.
As the input value increases, the boost increases sooner; overshooting and/or unstable boost pressure may occur.
As the Response Value changes, the boost slightly changes as well.
- Over Boost Value Setting Range: 0 - 250 kPa (0.0 - 36.0 PSI). Default Setting: 80 kPa (11.6 PSI)
The boost can be set to maximize the turbine performance regardless of the Off Set Value and Response Value. As the value increases, it may over shoot the Off Set Value Setting.
- Warning Value Setting Range: 0 - 250 kPa (0.0 - 36.0 PSI). Default Setting: 80 kPa (11.6 PSI)
When the boost exceeds the Warning Value, the warning function will be activated.
- ※ Warning Function This function warns the user of an excessive boost increase by an audible buzzer sound and a "WRN" sign on the monitor.
The boost pressure will be decreased from the Off Set Value by the percentage of the set Drop Value.
This function activates when the boost pressure exceeds the Warning Value for a certain period of time. This function may not be activated if the boost increases excessively only for a short period of time.
- Drop Value Setting Range: 0-100%. Default Setting: 100%.
When the boost pressure exceeds the Warning Value, the boost pressure will be decreased from the Off Set Value by the percentage of the set Drop Value.

1-2. Control Off Mode

This mode turns off the Boost Control Mode. The boost will return to the factory boost control. (The boost will be at the lowest value.)

1-3. Display

- Normal Display The boost value (kPa or PSI) reads in real time.
- Peak Hold Display The maximum recorded boost pressure value appears.
Pressing the switch can reset the value under this display.
- After Image Display The maximum boost pressure value blinks for 3 seconds when the boost pressure changes from positive pressure to negative pressure.

Simple Setting

Read the operational instructions from Section 1 "Modes & Display Descriptions" before carrying out the following simple boost settings.

1. Enter the boost value slightly higher than the actual target boost setting.

NOTE

Even if the boost increases excessively, the Warning Function activates to decrease the boost to the set Drop Value (Ref. P.22) to avoid damage to the engine or turbo.

2. Enter the target boost value as the Off Set Value.

CAUTION

Change this value in small increments.

If the value is changed drastically, the boost may increase excessively causing damage to the engine or turbo.

3. Edit the Over Boost Value until the boost does not overshoot, or stays within the Off Set Value to increase the boost smoothly.

4. Increase the Response Value for better response and to prevent the boost from dropping at high engine RPM.

Make sure the appropriate value is entered as the Response Value.

If the Response Value is too high, it may cause unstable boost.

NOTE

If a higher Response Value is entered and the actual boost is lower than 100kPa, the boost tends to increase. If a higher Response Value is entered and the actual boost is higher than 100kPa, the boost tends to decrease. When editing the Response Value, the Off Set Value must be adjusted accordingly.

※Refer to the graphs below for setting:

(The boost changes as the dotted line shows when the settings are changed as described in the graphs.)

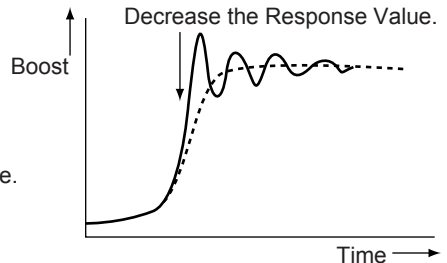
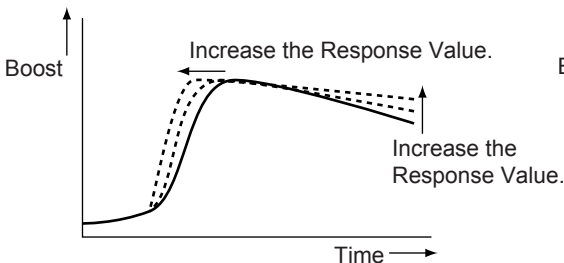
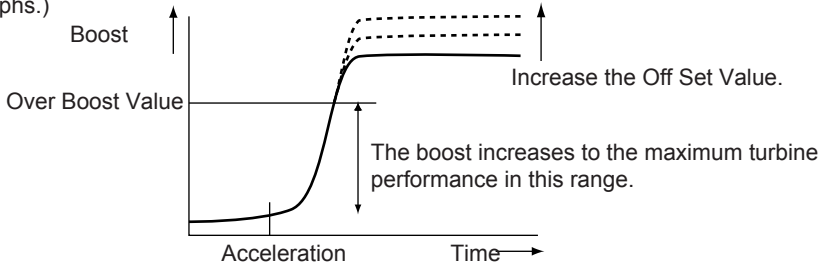

2. Operation Outline

Ignition On

↓ If the unit was previously in the Control Off Mode, it will remain in that mode when the ignition is turned on.

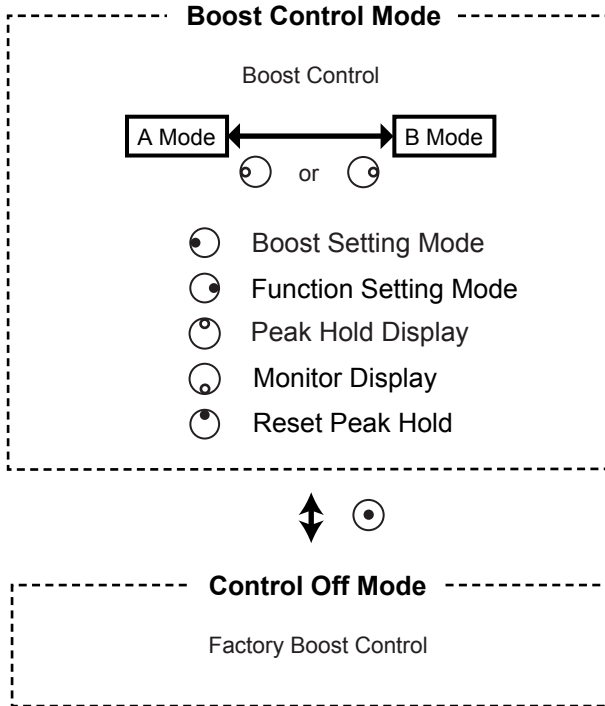

Switch Operating Description

- Press the upper side.
- Press the lower side.
- Press the left side.
- Press the right side.
- Press the center.
- Press quickly.
- Press longer than a second.

Boost Setting Mode

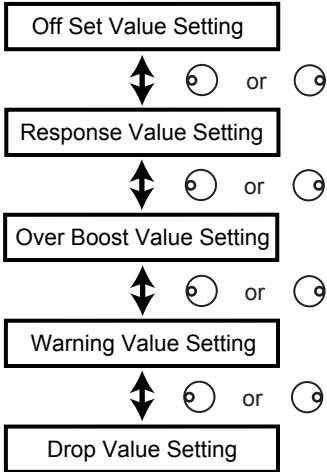

- or To edit value(±1)
- or To edit value(±10)
- To return to the Boost Control Mode

Function Setting Mode

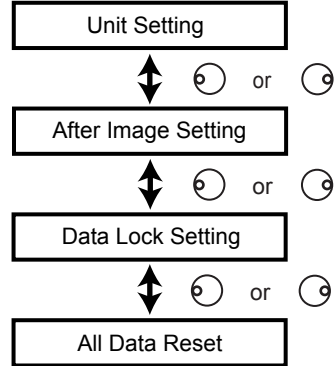

- or To edit setting
- To return to the Boost Control Mode

Data Lock Setting

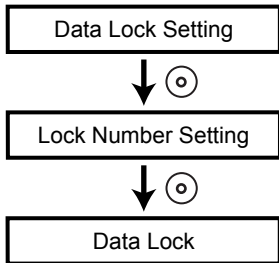

- or To edit number
- or To change digit

All Data Reset

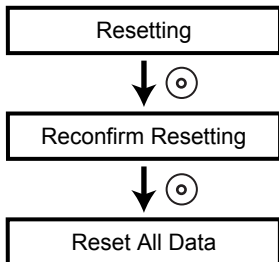

Press any switch direction to return to the Function Setting Mode without resetting data.

3. Boost Control Mode

3-1. Boost Control

The boost pressure is controlled by the set value of either A Mode or B Mode.

Select "A" to control the boost pressure values set in A Mode. Select "B" to control the boost pressure values set in B Mode.

To switch between A Mode and B Mode, press the left or right side of the switch.

To move to the Boost Setting Mode, press the left side of the switch longer than a second.

To move to the Function Setting Mode, press the right side of the switch longer than a second.

To move to the Control Off Mode, press the center of the switch longer than a second.



Press the left or right side of the switch to select A or B Mode.

----- Selected mode "A" or "B" is shown.



Press the left side of the switch longer than a second to go to the Boost Setting Mode.



Press the right side of the switch longer than a second to go to the Function Setting Mode.



Press the center of the switch longer than a second to activate the Control Off Mode.

3-2. Boost Display

The boost pressure value is displayed under the Boost Control Mode.

The display can be switched to the Peak Hold value by pressing the upper side of the switch.

To reset the Peak Hold value, press the upper side of the switch longer than a second while the Peak Hold value is displayed.

When pressing the lower side of the switch while the Peak Hold value is displayed, the current boost pressure value is displayed.

If the After Image display function is set under the Function Setting Mode, the maximum boost pressure value will blink for 3 seconds when the boost pressure changes from positive pressure to negative pressure.

If an incorrect boost value is displayed, stop the engine and reset all data so the sensor's values can be recalibrated.

To reset all data, refer to "All Data Reset" in Section 6-4.

※Record all current settings before resetting all data

3-2.1 Monitor Display

The monitor shows the boost pressure value that is being measured through the Boost Sensor in real time. To switch the display to show the Peak Hold value, press the upper side of the switch.



Monitor Display:

Press the upper side of the switch to see the Peak Hold value.

3-2. 2 Peak Hold Display

The Peak Hold Display shows the maximum boost pressure value from the recorded boost pressure data.

While the Peak Hold Display is selected, "P.H." appears on the monitor.

To reset the Peak Hold value, press the upper side of the switch longer than a second while the Peak Hold Display is selected.

Press the lower side of the switch to return to the Monitor Display.



Peak Hold Display:

Press the lower side of the switch to return to the Monitor Display.

3-2. 3 After Image Display

The After Image Display blinks the maximum boost pressure value for 3 seconds when the boost pressure changes from positive pressure to negative pressure. After 3 seconds, the display returns to the Boost Display.



After Image Display:

The value on the monitor blinks when in the After Image Display.

3-3. Warning

The Warning function activates when the actual boost pressure exceeds the set warning value.

The unit warns the user by a buzzer, and decreases the boost pressure to the set drop value.

While the Warning function is activated, "WRN" appears and the display blinks.



The monitor blinks when the Warning function is activating.

4. Control Off Mode

This mode deactivates the EVC-S boost control and reverts to the factory boost control.

In this mode, neither "A" nor "B" will appear on the monitor.

The boost pressure value can be displayed in this mode.

Press the center of the switch to go to the Boost Control mode.



The monitor will display a value when in the Control Off Mode.

5. Boost Setting Mode

This mode is to set the following values for boost control: "Off Set Value", "Response Value", "Over Boost Value", "Warning Value", and "Drop Value."

Press the left side of the switch longer than a second to go to the Boost Setting Mode under the Boost Control Mode.

The set values are saved to either A Mode or B Mode selected in the Boost Control Mode.

Press the upper side of the switch once to increase the value by 1, and press the lower side to decrease the value by 1.

Press the upper side of the switch longer than a second to increase the value by 10, and press the lower side longer than a second to decrease the value by 10.

Press the left or right side of the switch to select the item to be set.

Press the left side of the switch longer than a second to return to the Boost Control Mode.

When no operation is done for approximately 120 seconds, the mode returns to the Boost Control Mode.



Press the left or right side of the switch to select the item to be set.



Press the upper side of the switch to increase the value by 1, and press the lower side to decrease the value by 1.



Press the upper side of the switch longer than a second to increase the value by 10, and press the lower side longer than a second to decrease the value by 10.



Press the left side of the switch longer than a second to return to the Boost Control Mode.

5-1. Off Set Value Setting

When setting the Off Set Value, "SET", "A" or "B", "OFS", and "%" appear on the monitor, and the Off Set Value will blink.

The Off Set Value setting range is 0 - 100 %.

As the Off Set value increases, the boost pressure increases, and vice versa.



Off Set Value Setting Display

5-2. Response Value Setting

When setting the Response Value, "SET", "A" or "B", "RSP", and "%" appear on the monitor, and the Response Value will blink.

The Response Value setting range is 0 - 100 %.

As the Response Value increases, the boost pressure increases sooner, overshooting and/or unstable boost pressure may occur.



Response Value Setting Display

5-3. Over Boost Value Setting

When setting the Over Boost Value, "SET", "A" or "B", "OPT", "P.H", and "kPa" or "PSI" appear on the monitor, and the Over Boost Value will blink.

The Over Boost Value setting range is 0 - 250kPa or 0.0 - 36.0PSI.

The boost can be set to maximize the turbine performance regardless of the Off Set Value and Response Value. As the value increases, it may over shoot the Off Set Value Setting.



Over Boost Value Setting Display

5-4. Warning Value Setting

When setting the Warning Value, "SET", "A" or "B", "WRN", and "kPa" or "PSI" appears on the monitor, and the Warning Value will blink.

The Warning Value setting range is 0 - 250kPa or 0.0 - 36.0PSI.

When the boost pressure exceeds the set Warning Value, a buzzer sounds and the boost value decreases to the Drop Value setting to protect the engine and turbocharger from excessive boost.



Warning Value Setting Display

5-5. Drop Value Setting

When setting the Drop Value, "SET", "A" or "B", "DRO", and "%" appear on the monitor, and the Drop Value will blink.

The Drop Value setting range is 0 - 100 %.

The Drop Value is the value the boost pressure drops to under the Warning Function.



Drop Value Setting Display

6. Function Setting Mode

This mode is for setting of the following: "Boost Unit of Measure Setting", "After Image Display", "Data Lock" and "All Data Reset."

Press the right side of the switch longer than a second to go to the Function Setting Mode under the Boost Control Mode.

Press the left or right side of the switch to select the item to set.

Press the right side of the switch longer than a second to return to the Boost Control Mode.

When no operation is done for approximately 120 seconds, the mode returns to the Boost Control Mode.

6-1. Boost Unit of Measure Setting

The boost pressure unit of measure is selectable between kPa and PSI.

Press the upper or lower side of the switch to select the unit of measure.



6-2. After Image Display

Under the normal display, an After Image Display showing the highest positive boost pressure can be selected to display. To select the After Image Display, refer to the following procedure.



To display the After Image Display, select "ON."
"AI" and "ON" will alternately blink on the monitor.



To not display the After Image Display, select "OFF."
"AI" and "OFF" will alternately blink on the monitor.



To switch between "ON" and "OFF", press the upper or lower side of the switch.
Make sure the selected setting appears on the monitor.

6-3. Data Lock

The set values can be locked by entering a lock number to prevent unintentional editing of data. To edit data again after locking, enter the lock number to release.



When setting the Data Lock, "LOCK" blinks on the lower right corner of the monitor. When the Data Lock is on, "ON" appears, and when the Data Lock is off, "OFF" appears.



To turn on or off the Data Lock, press the center of the switch.



When setting the lock number, enter the digit of the lock number that blinks on the monitor. When entering the number, refer to the instructions in Section 5.



To change the digit, press the left or right side of the switch. The position of the blinking digit should be changed.



Press the center of the switch once the lock number is set.



When the Data Lock is on, "ON" and "LOCK" appears on the monitor. Data cannot be edited if a wrong lock number is entered.

6-4. All Data Reset

All set values can be reset to the default settings.

After resetting the data, no data is retrievable.

If the lock number is forgotten, reset all data and set a new lock number.

CAUTION

When resetting all data, stop the engine so the sensor's values can be learned at 0 boost (atmospheric pressure) If not, incorrect sensor values are learned, and the boost pressure will be calibrated incorrectly.



When All Data Reset is selected, "RES" blinks on the monitor. Press the center of the switch to reset all data.



Before resetting all data, "CLr" appears on the monitor. Press the center of the switch to reset all data to the default setting.



To cancel resetting all data, press the upper, lower, left, or right side of the switch while "CLr" appears on the monitor.



"StP" appears on the monitor and returns to the Function Setting Mode without resetting the data.

7. Error Display

The EVC-S has a self diagnosis function. If the EVC-S detects any unusual condition, an error number appears on the monitor and the boost pressure is reduced to the factory boost pressure setting.

When an error number appears on the monitor, inspect the cause referring to the table below. If the cause of the error can not be figured out, contact an Authorized HKS Dealer.



← Error number 2 appears.



← Error number 5 appears.

Error No.	Description	Item to Inspect
2 or 3	Boost Sensor Malfunction	Boost Sensor wiring
4 or 5	Power Supply/Voltage Error	Battery voltage and/or power supply harness.
5	Solenoid Valve Malfunction	Solenoid Valve wiring
6	EVC-S Communication Error	Wiring between the Display Unit and Control Unit.
Other	Other Error	Contact an Authorized HKS Dealer.

OPTIONAL PARTS LIST

The list below are optional parts for the EVC-S. Use any of the following parts if necessary for installation.

No.	Part Number	Description	Remarks
1	4599-RA008	Hose Set for Poppet Valve	To install EVC-S with Poppet Valve.
2	4599-RA009	Hose Set for Twin Turbochargers	To install EVC-S with Twin T/C.
3	4599-RA010	4mm Hose Set	To install EVC-S using 4mm hose.
4	4599-RA011	Hose Set for Swing Valve	included in EVC-S
5	90461-010004	4mm Silicone Hose	1 ft. increments <input type="checkbox"/>
6	90461-010006	6mm Silicone Hose	1 ft. increments
7	14999-AK018	4mm Rubber Cap	
8	14999-AK019	6mm Rubber Cap	

MAINTENANCE



CAUTION

- Consult a professional to carry out operations not shown in this manual.
- Replace the vacuum filter more frequently if excessive dirt build-up is noticed. This will prevent the filter from being blocked by dirt which may cause damage to the engine.

- Inspect and maintain the vehicle daily for optimal performance.
- Clean your hands and remove dirt and oil before handling this product. This will help prevent damage to the case.
- When cleaning this product, do not use solvents such as alcohol, thinner, benzene, glass cleaner, and oil. Wipe off dirt with a dry soft cloth.
- If dirt builds up in a vacuum filter extremely early, change the location of the hose on the engine. If changing the hose location does not improve the dirt build-up, there may be an issue with the engine. Consult a professional.

TROUBLESHOOTING

If this product is not functioning properly, make sure all wiring and/or hose routing is connected properly and refer to the symptoms described below.

SYMPTOM	CAUSE	SOLUTION
The unit does not turn on.	Bad connection.	Connect the crimp connector securely.
	Fuse is blown.	Replace the fuse and make sure the harness is not shorted.
	Ground is disconnected or bad.	Remove paint or rust from the grounding point.
Error Number appears.	Refer to Section 7.	Refer to Section 7.
Boost is unstable.	Actuator incapacity Insufficient valve area/stroke	Check the actuator characteristics and adjust accordingly (if applicable).
Boost does not increase.	Insufficient turbo output capacity.	Reset all values within capable setting range.
Boost control malfunction	Incorrect settings.	Reset and re-enter all data.
	Incorrect hose connections.	Make sure hose connections are correct using the proper exhaust bypass hose routings.
	Hose(s) are disconnected or cut.	Check hoses, replace if necessary.
	Dirt buildup in the vacuum filter.	Replace the vacuum filter.
Boost increases excessively.	Incorrect matching of Response or Overboost Value.	Input a smaller number than the current Response or Overboost Value.
Warning function doesn't work.	Boost exceeds the Warning Value for insufficient time.	Input a smaller number than the current Warning Value.
Setting cannot be changed.	Data Lock is on.	Turn off the Data Lock.
Warning function activates when the power is on.	The sensor learning value of the boost sensor is incorrect.	Reset all data with the engine off and the Ignition key in the ON position. (Ref. 6-4)



WARNING

- Do not use this product if any unusual noises or scents are detected. Consult your Authorized HKS Dealer immediately. Otherwise, it may cause electrical shock or fire.



CAUTION

- Do not try to repair this product yourself. Consult your Authorized HKS Dealer.
- If any unusual noises, scents, and/or vibrations are noticed while driving, please refer to the factory repair manual.

REPAIR SERVICE

For questions about this product or for any optional, missing, defective and/or damaged parts, please contact your Authorized HKS Dealer.

FOR SUBSEQUENT OWNERS

If this product is passed on to a new owner, make sure this instruction manual is included along with the product. Do not uninstall this product by yourself unless qualified to do so.



CAUTION

- After removal of this product, insulate all wires used with electrical tape. Otherwise, electrical devices may short circuit or become damaged.

PRODUCT SPECIFICATIONS

- Operating VoltageDC 11 - 16V
- Controllable Boost PressureUp to 250 kPa(36 PSI)
- Operating Temperature
 - Display Unit $-10^{\circ}\text{C}\sim 70^{\circ}\text{C}$
 - Valve $-20^{\circ}\text{C}\sim 80^{\circ}\text{C}$
- Maximum Electrical Power Consumption 8.0W

Unit Conversion Table

	Engineering Unit = SI Unit	SI Unit = Engineering Unit
Output	1 P S = 0.735 kW	1 kW = 1.36 P S
Torque	1 kg f · m = 9.81 N · m	1 N · m = 0.102 kg f · m
Pressure	1 kg f / cm ² = 98.1 kPa	1 kPa = 0.0102 kg f / cm ²
	1 P S I = 6.895 kPa	1 kPa = 0.14504 P S I
Atmospheric Pressure	1 mm Hg = 0.1333 kPa	1 kPa = 7.50 mm Hg

REVISION OF MANUAL

Ver No.	Date	Details
3-1.01	2009/10	1st Edition



Pursuing the Ultimate in Engine Performance and Efficiency.
Produced by HKS Company Limited.