

# SSA2servo amplifier

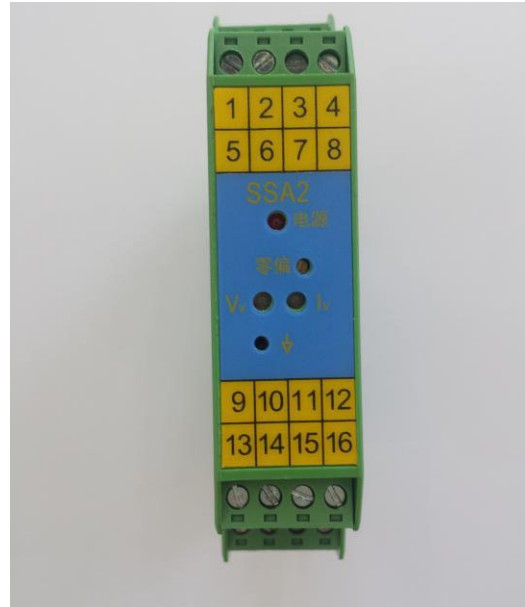

## Content

| details                           | The page of number |
|-----------------------------------|--------------------|
| Function                          | 1                  |
| Feature                           | 1                  |
| Technical parameters              | 2                  |
| Ordering models                   | 3                  |
| Working Principle (Block Diagram) | 3                  |
| pin assignment                    | 4                  |
| Jumper description                | 4                  |
| Dimensions                        | 5                  |
| Notes                             | 6                  |

## Function

SSA2 servo amplifier is a dedicated amplifier for driving electro-hydraulic servo valves. This amplifier can accept three types of standard signal sources. After conversion and amplification, it can drive most types of nozzle baffle servo valves, jet tube servo valves, and direct-acting servo valves at home and abroad. Type servo valve and other electro-hydraulic servo valves.

## Feature

- Input signal selectable
- $\pm 10\text{mA} \setminus \pm 10\text{V} \setminus 4 \sim 20\text{mA}$
- Output signal optional
- $\pm 5\text{mA} \setminus \pm 10\text{mA} \setminus \pm 20\text{mA} \setminus \pm 40\text{mA} \setminus$
- $\pm 50\text{mA} \setminus \pm 100\text{mA} \setminus \pm 200\text{mA} \setminus \pm 10\text{V}$
- Output signal positive and negative

indication

Mounts directly on 35mm DIN rail

- Optional dither signal
- Adopt 35mm DIN rail installation

Installation method:

## Technical parameter

Contact us if other models

Sheet 1 SSA2Servo Amplifier Technical Parameters

| Function                          | Technical parameter  |
|-----------------------------------|--|
| <b>Supply voltage</b>             | +24V DC@500mA power.<br>The maximum power supply voltage range is not more than 36V, and the minimum is not lower than 18V   |
| <b>Temperature</b>                |  |
| <b>Using temperature</b>          | 0° C ~ 40° C   |
| <b>Saving temperature</b>         | -40° C ~ 85° C   |
| <b>Command input</b>              | Command input: Can receive $\pm 10\text{mA}$ \ $\pm 10\text{V}$ \ 4 ~ 20mA input   |
| <b>Flutter signal</b>             | Frequency 300Hz, $\pm 20\%$ in amplitude adjustable  |
| <b>Servo valve signal output:</b> |  |
| <b>Current output mode:</b>       | $\pm 5\text{mA}@2400 \ \Omega$ maximum load \ $\pm 10\text{mA}@1200 \ \Omega$ maximum load \ $\pm 20\text{mA}@600 \ \Omega$ maximum load \ $\pm 40\text{mA}@300 \ \Omega$ maximum load \ $\pm 50\text{mA}@240 \ \Omega$ maximum load \ $\pm 100\text{mA}@120 \ \Omega$ maximum load \ $\pm 200\text{mA}@60 \ \Omega$ maximum load \ 4 ~ 20mA@600 $\Omega$ maximum load \ |
| <b>Voltage output mode</b>        | $\pm 10\text{V}@1000 \ \Omega$ minimum load \  |
| <b>Vv LED</b>                     | <b>Positive voltage output = red</b><br><b>Negative voltage output = green</b>   |
| <b>Iv LED</b>                     | <b>Positive current output = red</b><br><b>Negative current output = green</b>   |
| <b>Degree of protection</b>       | IP20   |
| <b>Size:</b>                      | Guide: 100 (W) $\times$ 115(H) $\times$ 25.4(L)mm  |
| <b>Weight:</b>                    | 0.16kg   |

## ORDERING MODELS

---

SSA2-□-□-□

Сигнал управления

- 1:  $\pm 10\text{mA}$
- 2: 4-20mA
- 3:  $\pm 10\text{V}$  (стандарт)

Сигнал от датчика обратной связи:

- 1: Нет (стандарт)
- 2: Есть

Выходной сигнал на клапан:

- 1:  $\pm 5\text{mA}$
- 2:  $\pm 10\text{mA}$
- 3:  $\pm 20\text{mA}$
- 4:  $\pm 40\text{mA}$
- 5:  $\pm 50\text{mA}$  (стандарт)
- 6:  $\pm 100\text{mA}$
- 7:  $\pm 200\text{mA}$
- 8:  $\pm 10\text{V}$

## Working Principle (Block Diagram)

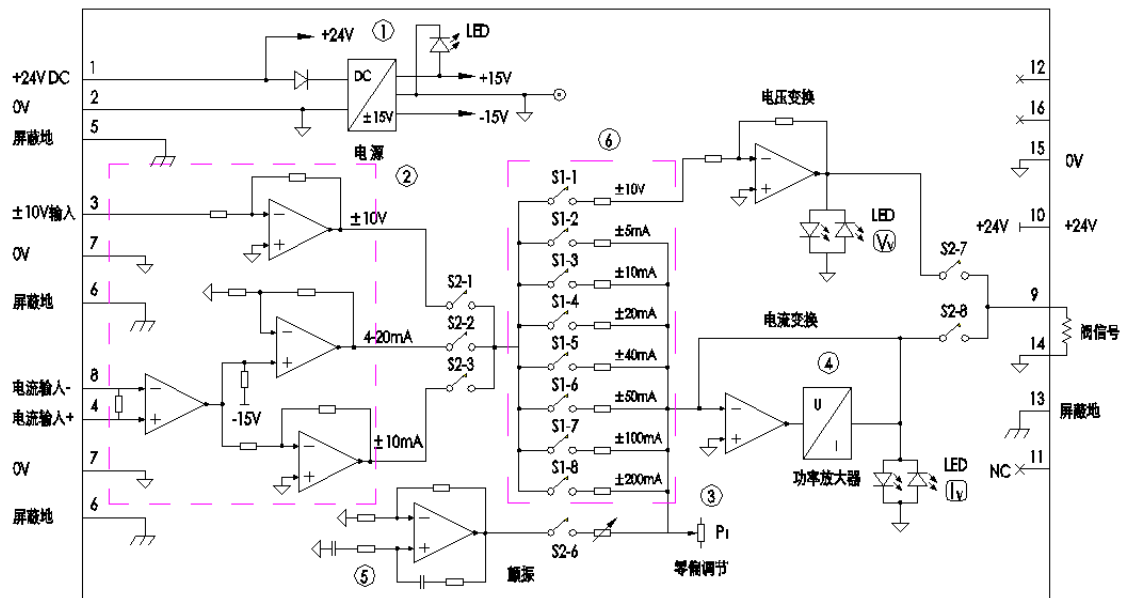
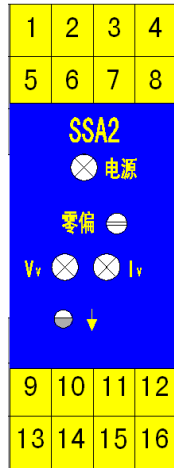

Figure 1 SSA2 servo amplifier functional block diagram

Function and principle:

- ① The function of the power conversion circuit is to convert the external DC24V power supply into  $\pm 15V$  power supply for the internal circuit of the servo amplifier.
- ② The function of the preamplifier circuit is to convert different types of command signals into standard  $\pm 10V$  signals, so as to adapt to the input signal requirements of the power amplifier circuit, so that the front and rear stages of the circuit voltage can match.
- ③ The function of the zero adjustment circuit is to adjust the zero position of the output current.
- ④ The function of the current limiting function is to limit the maximum output current of the servo amplifier itself to no more than 210mA.
- ⑤ The function of the flutter signal generating circuit is to generate a standard sinusoidal signal, the frequency is about 305HZ, and the amplitude is adjustable in the range of  $\pm 20\%F.S.$
- ⑥ The function of the gain selection circuit is to change the gain of the amplifier through the dial switch to change the output current.

## Pin assignment



| SSA2伺服放大器端子定义   |              |
|-----------------|--------------|
| 1:电源+ / +24V DC | 9 :阀信号+      |
| 2:电源- / 0V      | 10: +24V电源输出 |
| 3:电压输入信号+       | 11:NC        |
| 4:电流输入信号+       | 12:NC        |
| 5:屏蔽地           | 13:屏蔽地       |
| 6:屏蔽地           | 14:信号地/阀信号-  |
| 7:信号地/电压输入信号-   | 15:信号地       |
| 8:电流输入信号-       | 16:NC        |

Figure 2 Terminal Definition Diagram

The SSA2 servo amplifier interface and its definition are shown in Figure 2. Refer to the schematic diagram of the servo amplifier in Figure 1 to complete the wiring

### Jumper description

If the user needs to change the input signal and output signal, it can be realized by toggling the S1 and S2 selection switches inside the module.

| Signal         | S1     |   |   |   |   |   |   |   | S2 |   |   |   |   |   |   |   |
|----------------|--------|---|---|---|---|---|---|---|----|---|---|---|---|---|---|---|
|                | 1      | 2 | 3 | 4 | 5 | 6 | 7 | 8 | 1  | 2 | 3 | 4 | 5 | 6 | 7 | 8 |
| Input          | ±10V   |   |   |   |   |   |   |   | √  |   |   |   |   |   |   |   |
|                | ±10mA  |   |   |   |   |   |   |   |    | √ |   |   |   |   |   |   |
|                | 4~20mA |   |   |   |   |   |   |   |    |   | √ | √ |   |   |   |   |
| Output         | ±5mA   |   | √ |   |   |   |   |   |    |   |   |   | √ |   |   | √ |
|                | ±10mA  |   |   | √ |   |   |   |   |    |   |   |   | √ |   |   | √ |
|                | ±20mA  |   |   |   | √ |   |   |   |    |   |   |   | √ |   |   | √ |
|                | ±40mA  |   |   |   |   | √ |   |   |    |   |   |   | √ |   |   | √ |
|                | ±50mA  |   |   |   |   |   | √ |   |    |   |   |   | √ |   |   | √ |
|                | ±100mA |   |   |   |   |   |   | √ |    |   |   |   | √ |   |   | √ |
|                | ±200mA |   |   |   |   |   |   |   | √  |   |   |   | √ |   |   | √ |
|                | ±10V   | √ |   |   |   |   |   |   |    |   |   |   |   |   |   | √ |
| Flutter enable |        |   |   |   |   |   |   |   |    |   |   |   |   | √ |   |   |

## Dimensions

Unit: mm

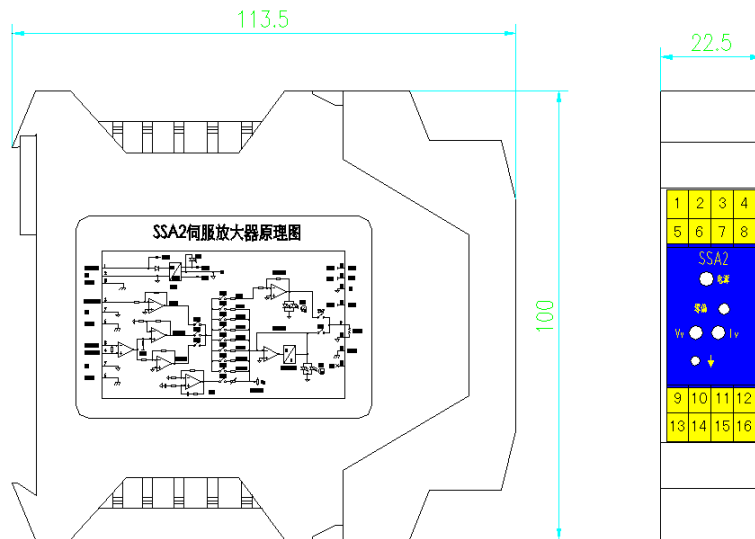

### Note:

—— It is recommended to use shielded wire, recommended specifications Germany ANYFLEX-PVC-CY-OZ/JZ-001PVCCY0070015

—— Recommended cable length: The voltage signal is not greater than 20 meters; the current signal is not greater than 1000 meters.