

AN7135

Dual 7.5W Low Frequency Power Amplifier Circuit

■ Overview

The AN7135 is a power amplifier circuit of 7.5W (15.0V, 3Ω) output. It can provide stereo operation since two amplifiers are incorporated in a chip. Static circuit current is very smaller than conventional IC for power amplifier, and various protective circuits are incorporated, thus providing high reliability. For its feature of very small static circuit current, it is best suitable for dry cell operating sets (e.g. radio cassette recorder). It requires smaller number of external components because it has little distortion and low noise and can support the stand-by condition.

■ Features

- Small static circuit current
- Stand-by condition supported
- Good oscillation stability
- Little unwanted radiation to RF portion of AM/FM
- Little distortion
- Low noise
- Small shock noise at power ON/OFF, stand-by ON/OFF
- Fewer external components

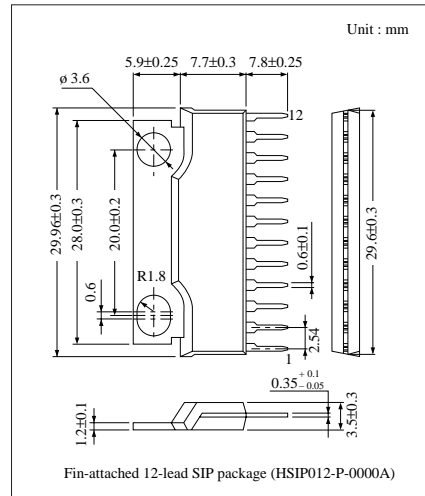

■ Block Diagram

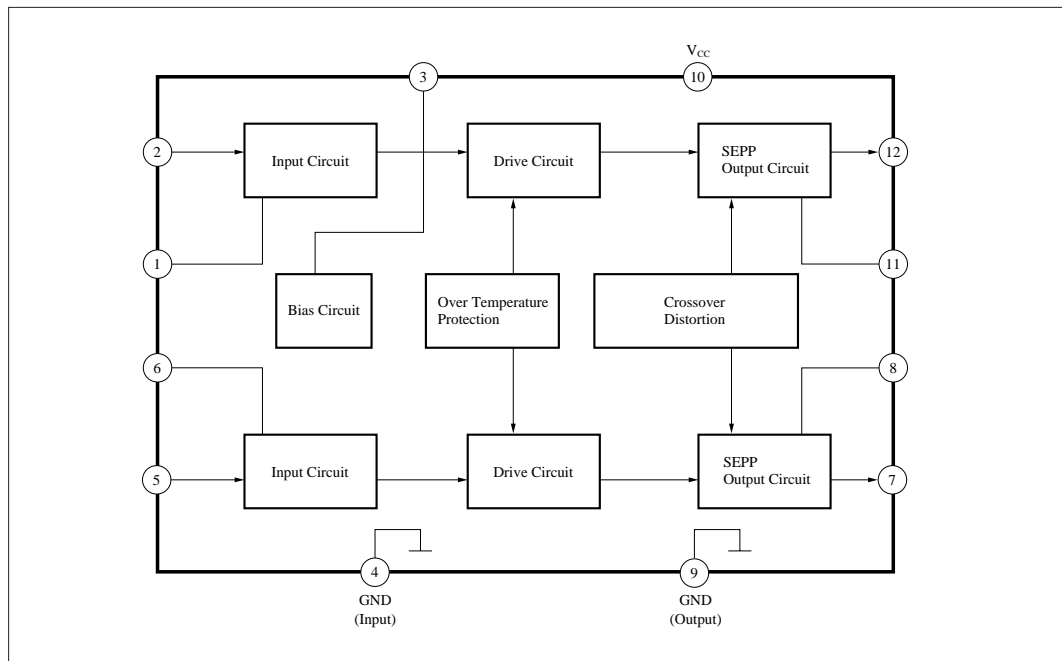

■ Pin Name

Pin No.	Pin Name	Pin No.	Pin Name
1	Negative Feedback Ch.1	7	Output Ch.2
2	Input Ch.1	8	Boot-strap Ch.2
3	Ripple filter/Stand-by Controller	9	GND (Output)
4	GND (Input)	10	V _{CC}
5	Input Ch.2	11	Boot-strap Ch.1
6	Negative Feedback Ch.2	12	Output Ch.1

■ Absolute Maximum Ratings (Ta= 25°C)

Parameter	Symbol	Rating	Unit
Supply Voltage	V _{CC}	24	V
Supply Current	I _{CC}	4	A
Power Dissipation ^{Note 1)}	P _D	62.5	W
Operating Ambient Temperature	T _{opr}	- 30 ~ + 75	°C
Storage Temperature	T _{stg}	- 55 ~ + 150	°C

Note) $\theta_{j-c} = 2^{\circ}\text{C/W}$

■ Recommended Operating Range (Ta= 25°C)

Parameter	Symbol	Range
Operating Supply Voltage Range	V _{CC}	5.5V ~ 18.0V

Note) 24V at no signals

■ Electrical Characteristics (V_{CC} = 15V, f_{IN} = 1kHz, R_L = 3Ω, Both channel drive, Ta= 25°C ± 2°C)

Parameter	Symbol	Condition	min.	typ.	max.	Unit
Quiescent Current	I _{CQ}	V _{IN} = 0mV	—	14	20	mA
Output End Noise Voltage ^{Note 1)}	V _{NO}	V _{IN} = 0mV, R _g = 10kΩ	—	0.25	0.50	mV
Voltage Gain	G _V	V _{IN} = 3mV	42.5	44.5	46.5	dB
Total Harmonics Distortion	THD	V _{IN} = 3mV	—	0.40	0.75	%
Max. Output Power	P _O	THD= 10%	7.0	7.5	—	W
Channel Balance	CB	V _{IN} = 3mV	-1	0	+ 1	dB
Ripple Rejection Ratio ^{Note 1)}	RR	V _{CC(ripple)} = 280mV, f _(ripple) = 120Hz R _g = 0Ω Sine wave	45	50	—	dB
Input Offset Voltage	V _{IN(O.S)}	Input pin open	—	10	30	mV
Stand-by Current	I _{STB}	Pin3 open	—	—	30	μA

Note 1) Measured through 15Hz to 30kHz (12dB/OCT) filter

■ Application Circuit

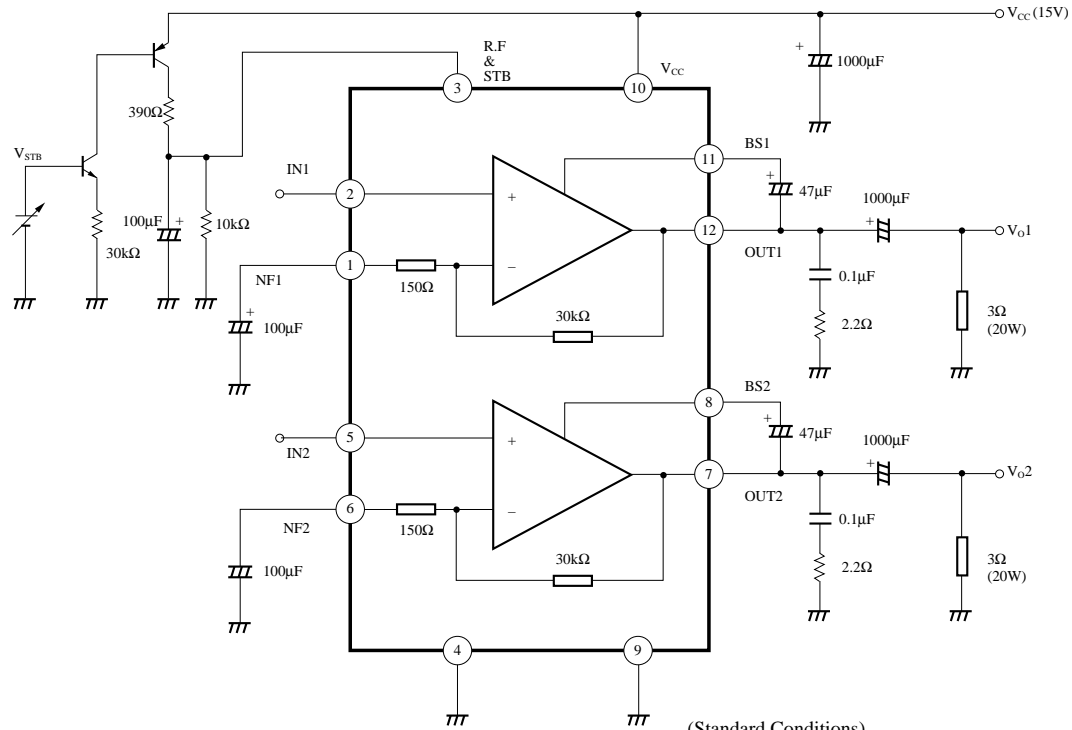

(Standard Conditions)

- $V_{CC} = 15V$
- $R_L = 3\Omega$
- $f_{IN} = 1kHz$
- $V_{IN} = 10mV$ or $3mV$
- $R_g = 600\Omega$
- $V_{STB} = 5.0V$
- Both Ch. Drive
- With heat sink
- Tr for stand-by SW
- NPN... 2SC828A
- PNP... 2SA564A

