

SV/SL...type Hydraulic Operated Check Valve



SV / SL...4XJ...type

Sizes 10, 16, 20, 25, 32
Max. Working Pressure: 315 bar
Max. Flow: 550 L/min

Contents

Function and configurations	02
Symbols	02
Specifications	03
Technical data	03
Characteristic curves	04
Unit dimensions	05-06

Features

- For sub-plate mounting, porting pattern conforms to DIN 24 340 Form D, ISO 5781
- For threaded connection
- With or without drain port
- With or without unloading function
- 4 cracking pressures

Function and configuration

SV and SL type valve is a hydraulic pilot operated check valve of poppet type design which may be opened to permit reverse flow. It is used for the isolation of operating circuits under pressure, to prevent a load from falling or creeping movements of hydraulically locked-in actuators. The valve consists of valve housing (1), poppet (2), compression spring (3), control spool (4) as well as an optional pre-opening ball poppet valve (5).

Type SV

The valve permits free-flow from A to B. In the reverse direction, the poppet (2) is held firmly on to its seat in addition to the spring force by the system pressure.

By applying pressure at control port X the control piston (4) is moved to the right. This lifts the poppet (2) from the seat, then fluid flows from B to A.

In order to ensure the valve opens due to the pressure applied to the control piston (4) a certain minimum pilot pressure is necessary.

Type SV...A...and SL...A...

This valve has an additional decompression feature. When pressure is applied at control port X the control piston (4) is pushed to the right. The ball poppet (5.1) leaves first then the poppet (2) leaves from the seat. Now the valve may also have a flow from B to A.

Because of the pre-opening there is a dampened decompression of the fluid under pressure to avoid possible pressure shocks.

Type SL...

The function of this valve corresponds to the valve SV. The difference is the additional leakage port Y. The annular area of the control piston (4) is separated from port A. The pressure at port A only effects area A4 (9) of the control piston (4).

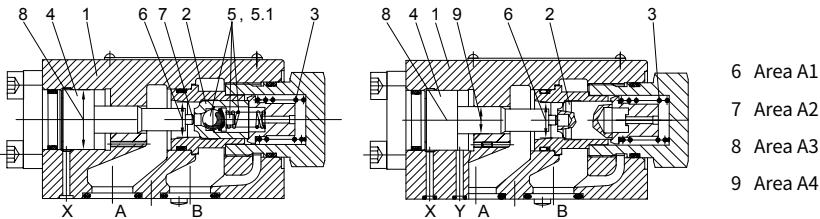

Symbols



Symbols type SV

Type SV..PA.-4XJ/...
(without drain port, with pre-opening)



Symbols type SL

Type SL..PB.-4XJ/...
(with drain port, without pre-opening)

Characteristic curves

(Measured at $t=40^{\circ}\text{C} \pm 5^{\circ}\text{C}$, using HLP46)

ΔP -Q curves – sub plate mounting

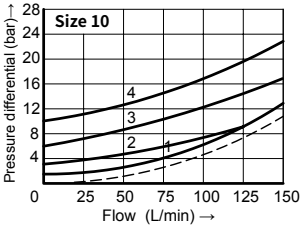

ΔP -Q curves – threaded connection

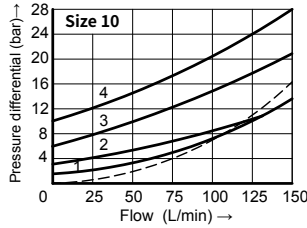

A to B Cracking pressure

- 1 1.5bar
- 2 3bar
- 3 6bar
- 4 10bar
- B to A

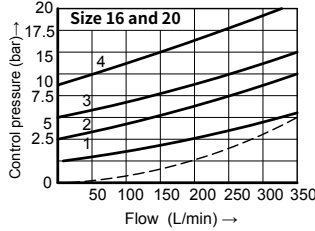
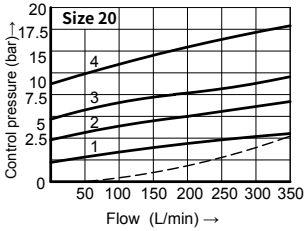

A to B Cracking pressure

- 1 2.5 bar
- 2 5bar
- 3 7.5bar
- 4 10bar
- B to A

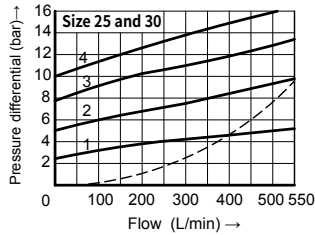
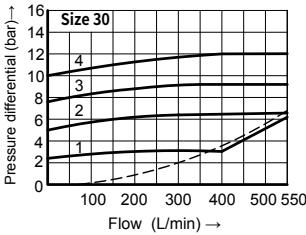

A to B Cracking pressure

- 1 2.5bar
- 2 5bar
- 3 7.5bar
- 4 10bar
- B to A

Control pressure-load pressure curves

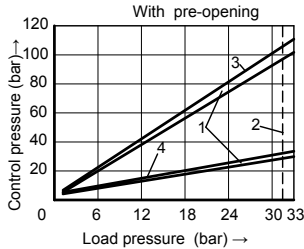
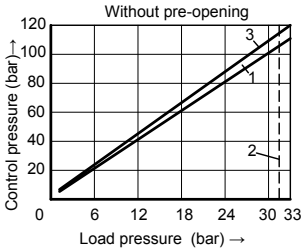

1 Tolerance range

- 2 Limit value
- 3 Poppet
- 4 Pre-opening ball poppet valve

Unit dimensions

(Dimensions in mm)

• sub-plate mounting valve

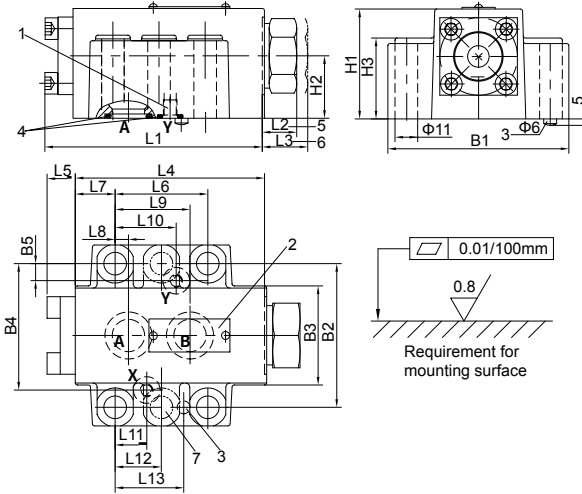

- 1 Port Y with valve type "SL" (with valve type "SV" this port is closed)
- 2 Name plate
- 3 Locating pin
- 4 O-rings

Size 10

- Ports A and B 17.12×2.62
- Ports X and Y 10×2.5 **Size 20**
- Ports A and B 24×3
- Ports X and Y 10×2.5 **Size 32**
- Ports A and B 34×3
- Ports X and Y 10×2.5

- 5 Valve with cracking pressure versions "1" and "2" (dimension L2)
- 6 Valve with opening pressure versions "3" and "4" (dimension L3)
- 7 6 valve mounting holes with type SV/SL 30

Type	Size	L1	L2	L3	L4	L5	L6	L7	L8	L9	L10
SV	10	100.8	15.5	15.5	87.8	13	42.9	18.5	7.2	35.8	-
	20	135	17.7	47.7	117	18	60.3	27.5	11.1	49.2	-
	32	156.1	36.1	46.1	134	22.1	84.2	39	16.7	67.5	-
SL	10	100.8	15.5	15.5	87.8	13	42.9	18.5	7.2	35.8	21.5
	20	135	17.7	47.7	117	18	60.3	27.5	11.1	49.2	39.7
	32	156.1	36.1	46.1	134	22.1	84.2	39	16.7	67.5	59.5

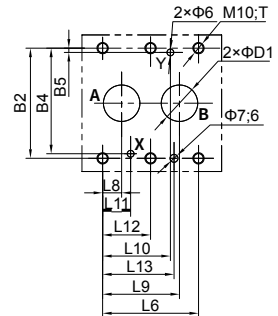

Type	size	L11	L12	L13	B1	B2	B3	B4	B5	H1	H2	H3	D1	T
SV	10	21.5	-	31.8	84	66.7	46	58.8	-	51	29	36	13	23
	20	20.6	-	44.5	100	79.4	63.5	73	-	70	37	55	22	24
	32	24.6	42.1	62.7	118	96.8	75	92.8	-	85	42.5	69	32	25
SL	10	21.5	-	31.8	84	66.7	46	58.8	7.9	51	29	36	13	23
	20	20.6	-	44.5	100	79.4	63.5	73	6.4	70	37	55	22	24
	32	24.6	42.1	62.7	118	96.8	75	92.8	3.8	85	42.5	69	30	25

Unit dimensions

(Dimensions in mm)

• threaded connection valve

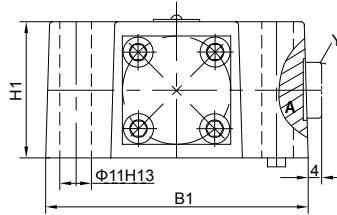
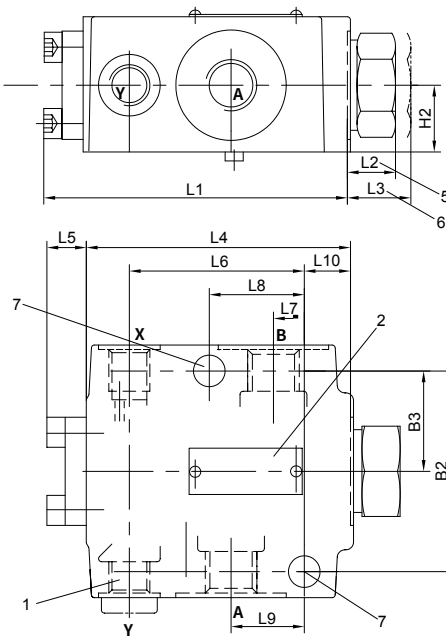

- 1 Port Y with valve type "SL" (with valve type "SV" this port is closed)
- 2 Name plate
- 5 Valve with cracking pressure versions "1" and "2" (dimension L2)
- 6 Valve with cracking pressure versions "3" and "4" (dimension L3)
- 7 2 valve mounting holes

Type	Size	Ports	
		A, B	X, Y
SV	10	G1/2 M22×1.5	G1/4 M14×1.5
	16	G3/4 M27×2	
	20	G1 M33×2	
	25	G11/4 M42×2	
	32	G11/2 M48×2	
SL	10	G1/2 M22×1.5	G1/4 M14×1.5
	16	G3/4 M27×2	
	20	G1 M33×2	
	25	G11/4 M42×2	
	32	G11/2 M48×2	

Type	Size	L1	L2	L3	L4	L5	L6	L7	L8	L9	L10	B1	B2	B3	H1	H2
SV	10	100.8	15.5	15.5	87.8	13	56.5	10.5	33.5	22.5	17.3	87	66.7	33.4	44	22
	16;20	133	17.7	47.7	115	18	74.5	17	50.5	36	27	105	79.4	39.7	68	34
	25;32	156.1	35.7	45.7	134	22.1	101	24	84	49	18	130	96.8	48.4	86	43
SL	10	100.8	15.5	15.5	87.8	13	56.5	10.5	33.5	22.5	17.3	87	66.7	33.4	44	22
	16;20	133	17.7	47.7	115	18	74.5	17	50.5	36	27	105	79.4	39.7	68	34
	25;32	156.1	35.7	45.7	134	22.1	101	24	84	49	18	130	96.8	48.4	86	43