

SFL218 Double nozzle baffle two-stage electro-hydraulic servo valve



□ Features

- Two-stage servo valve, flow control
- Adopt dry force motor and two-stage hydraulic amplifier structure
- Double nozzle baffle valve with no friction pair in front stage
- Large spool driving force
- High resolution, low hysteresis, excellent performance, high dynamic response
- Suitable for closed-loop control of position, force and velocity
- Can be used as a 3-way valve
- Optional fifth port for separate pilot control
- Disc oil filter for field replaceable pilot valve

□ Main Parameter

General parameters		
Operating medium		Mineral oil or other fluids according to DIN 51524
Viscosity range	mm ² /s	15 to 380 (30 to 45 recommended)
Oil temperature range	°C	-20 to +80 (recommended +40 to +50)
Storage temperature	°C	-20 to +60
Operating ambient temperature	°C	-40 to +120
Oil cleanliness		Maximum permissible degree of contamination of the oil, Class 6 per NAS 1638
Filtration accuracy		Recommended filter minimum filtration ratio β ₅ ≥75
Seal material		Nitrile rubber, fluorine rubber, or other sealing materials according to user needs
Installation Requirements		Install at any position, and ensure that the pilot stage has sufficient pressure (≥2MPa) when the system starts
Weight	k g	2.1

Technical Parameters

Work Pressure				
Oil mouth P, A, B	MPa	≤31.5		
Oil mouth T	MPa	≤21		
Rated flow (differential pressure ΔP=7MPa)	L/min	4;10	20	40;60
Zero bias	%	≤±2		
Hysteresis loop	%	≤4		
Resolution	%	≤1		
Non-linearity	%	≤7.5		
Asymmetry	%	≤7.5		
Endleak	L/min	≤1.5	≤2	≤3
Pressure Gain	%Pn/1%In	≥30		
Oil supply pressure zero drift (80~110%Pn)	%	≤±2		

Oil return pressure zero drift	%	≤±2		
Temperature zero drift (every 40°C change in temperature)	%	≤±2		
Amplitude bandwidth (3dB)	Hz	≥80	≥ 50	≥ 40
Phase bandwidth(-90°)	Hz	≥100	≥60	≥50
Valve body structure	Four-way, two-stage servo valve with spool and sleeve			
Pilot stage	Nozzle Flapper Valves			
Pilot oil supply method	Internal supply control oil, internal oil return			
Pilot Oil Filtration	With internal oil filter			
Installation form	ISO 10372-06-05-0-92			

Electrical Parameters

Valve protection type according to standard EN 60 529	IP65
Signal type	Analog quantity
Rated current per coil	m A 40
Each coil resistance	Ω 80 (according to user needs)
Socket	Standard electrical receptacle, mates with MS3106F14S-2S or other equivalent plug
Servo Amplifier	External servo amplifier (Model: HTSA101, ordered separately)

□ Electrical Wiring

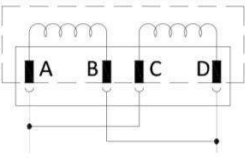
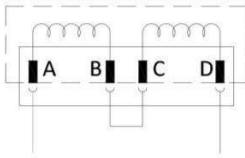
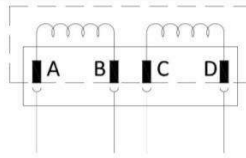
	Parallel connection	In series	Single Coil
Coil connection form			
Coil resistor (Ω)	40	160	80
Rated current (mA)	40	20	40
Coil inductance (H)	0.36	1.44	0.72
Input polarity when valve is at P→B, A→T	A and C (+), B and D (-)	A (+), D (-), B, C are shorted	A(+), B(-), or C(+), D(-)

Note: The pilot stage must first establish oil pressure before inputting electrical signals.

□ Dimensions and Interface

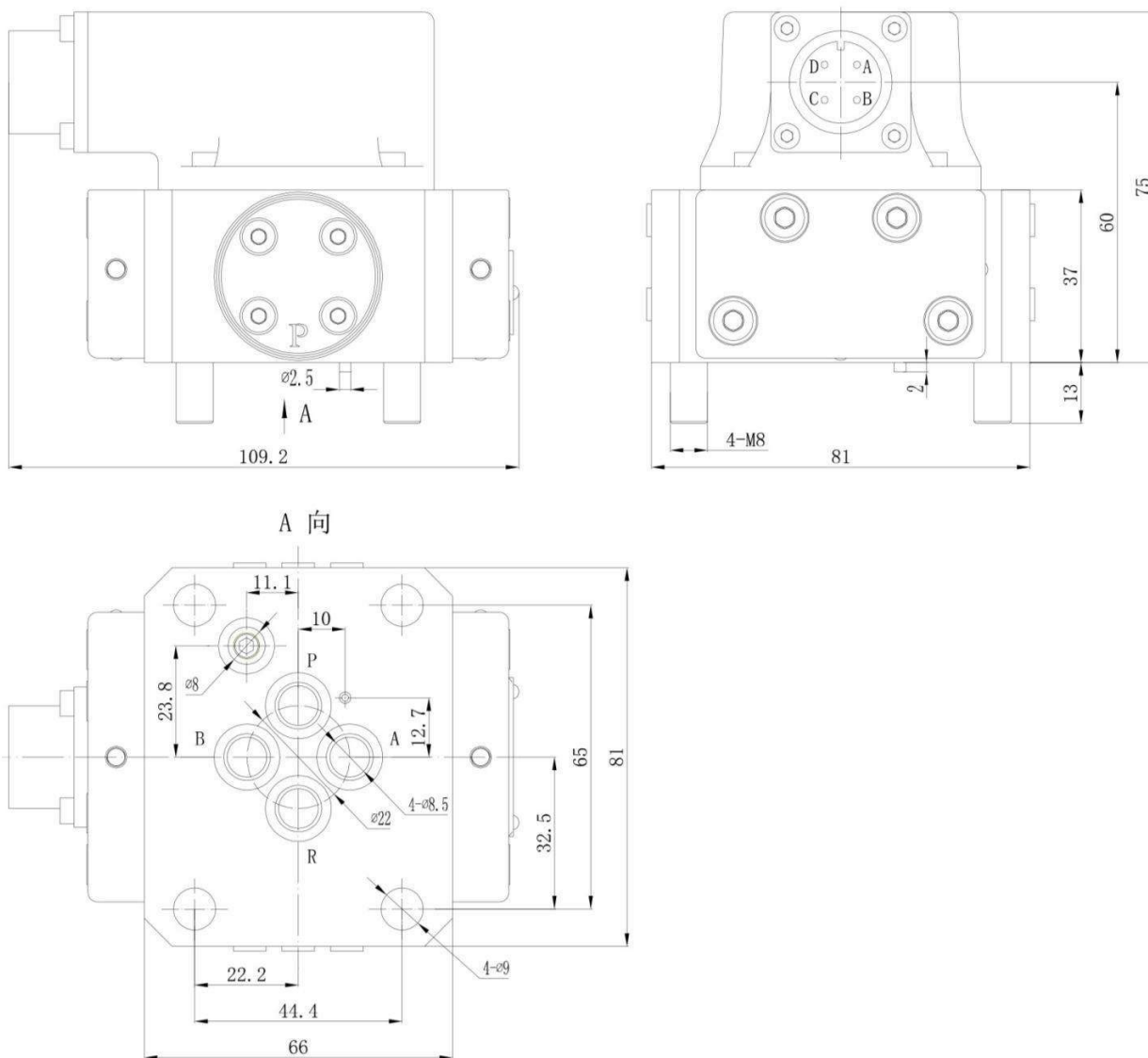

- The installation surface of the valve complies with ISO10372 - 06 - 05 - 0 - 92, the roughness of the installation surface of the valve is not less than $\sqrt{1.6}$, and the flatness is less than 0.01mm.
- In order to ensure that the servo valve can work normally, the system must be flushed before trial operation.

□ Spare Parts & Accessories

Parts or Accessories	Size or Specification	Quantity
NBR O-rings		
For P, T, A and B ports	10.6×1.8	4
For X ports	8.5×1.8	1
Configuration plug (degree of protection IP65)	14S2S	1
Mounting screw	M8×50	4
Protective base	PP or 2A12	1

□ **Ordering Information**

SFL218 —



Valve response type	
S	Standard Responses
H	High frequency

Rated flow	
When Pn=3.5MPa per section Qn[L/min]	
04	4
10	10
20	20
40	40
60	60

Maximum Working Pressure and Body Material			
F	21	MPa	Aluminum shell
K	35	MPa	Steel shell

Valve Spool Type	
O	Four-way, zero opening, linear flow gain
A	Four-way, 1.5% ~ 3% positive overlap, linear gain
D	Four-way, 10% positive overlap, linear gain
X	Customized on demand

Signal current for fully open valve			
15	±15	mA	Parallel connection
40	±40	mA	Parallel connection
80	±80	mA	Parallel connection
Customized on demand			

Valve Socket	
A	The socket is facing the A port
B	The socket is facing the B port
P	The socket is facing the P port
T	The socket is facing the T port

Seal material	
N	Nitrile Rubber (NBR) Standard Type
V	Viton (FPM)
Customized on demand	

Pilot valve control oil	
4	Internal Control
5	External control

The position of the spool when there is no control electric signal	
M	Centre position
A	P→B, A→T
B	P→A, B→T