

# DATA SHEET

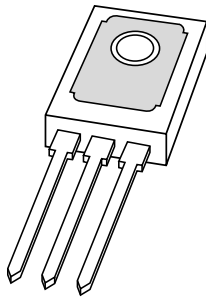

## **BD135; BD137; BD139** NPN power transistors

Product specification  
Supersedes data of 1997 Mar 04

1999 Apr 12

## NPN power transistors

## BD135; BD137; BD139

## FEATURES

- High current (max. 1.5 A)
- Low voltage (max. 80 V).

## APPLICATIONS

- Driver stages in hi-fi amplifiers and television circuits.

## DESCRIPTION

NPN power transistor in a TO-126; SOT32 plastic package. PNP complements: BD136, BD138 and BD140.

## PINNING

PIN	DESCRIPTION
1	emitter
2	collector, connected to metal part of mounting surface
3	base

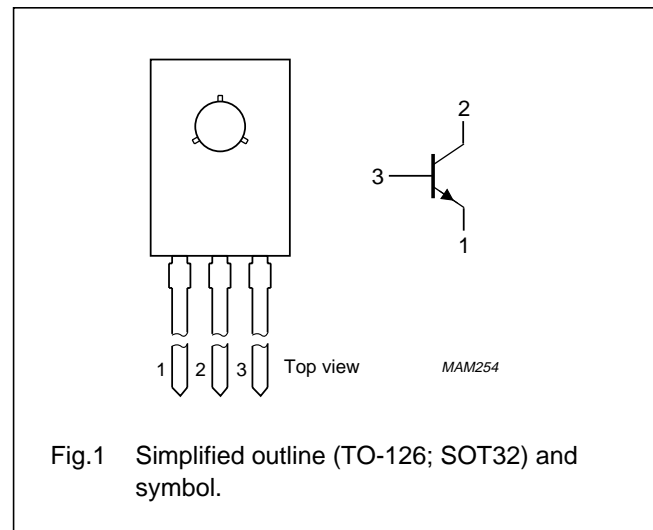

## LIMITING VALUES

In accordance with the Absolute Maximum Rating System (IEC 134).

SYMBOL	PARAMETER	CONDITIONS	MIN.	MAX.	UNIT
$V_{CB0}$	collector-base voltage	open emitter			
	BD135		–	45	V
	BD137		–	60	V
$V_{CE0}$	collector-emitter voltage	open base			
	BD135		–	45	V
	BD137		–	60	V
	BD139		–	80	V
$V_{EBO}$	emitter-base voltage	open collector	–	5	V
$I_C$	collector current (DC)		–	1.5	A
$I_{CM}$	peak collector current		–	2	A
$I_{BM}$	peak base current		–	1	A
$P_{tot}$	total power dissipation	$T_{mb} \leq 70\text{ °C}$	–	8	W
$T_{stg}$	storage temperature		–65	+150	°C
$T_j$	junction temperature		–	150	°C
$T_{amb}$	operating ambient temperature		–65	+150	°C

## NPN power transistors

## BD135; BD137; BD139

## THERMAL CHARACTERISTICS

SYMBOL	PARAMETER	CONDITIONS	VALUE	UNIT
$R_{th\ j-a}$	thermal resistance from junction to ambient	note 1	100	K/W
$R_{th\ j-mb}$	thermal resistance from junction to mounting base		10	K/W

## Note

1. Refer to TO-126; SOT32 standard mounting conditions.

## CHARACTERISTICS

$T_j = 25\text{ °C}$  unless otherwise specified.

SYMBOL	PARAMETER	CONDITIONS	MIN.	TYP.	MAX.	UNIT
$I_{CBO}$	collector cut-off current	$I_E = 0; V_{CB} = 30\text{ V}$	–	–	100	nA
		$I_E = 0; V_{CB} = 30\text{ V}; T_j = 125\text{ °C}$	–	–	10	$\mu\text{A}$
$I_{EBO}$	emitter cut-off current	$I_C = 0; V_{EB} = 5\text{ V}$	–	–	100	nA
$h_{FE}$	DC current gain	$V_{CE} = 2\text{ V};$ (see Fig.2)				
		$I_C = 5\text{ mA}$	40	–	–	
		$I_C = 150\text{ mA}$	63	–	250	
	$I_C = 500\text{ mA}$	25	–	–		
	DC current gain	$I_C = 150\text{ mA}; V_{CE} = 2\text{ V};$ (see Fig.2)	63	–	160	
	BD135-10; BD137-10; BD139-10 BD135-16; BD137-16; BD139-16		100	–	250	
$V_{CEsat}$	collector-emitter saturation voltage	$I_C = 500\text{ mA}; I_B = 50\text{ mA}$	–	–	0.5	V
$V_{BE}$	base-emitter voltage	$I_C = 500\text{ mA}; V_{CE} = 2\text{ V}$	–	–	1	V
$f_T$	transition frequency	$I_C = 50\text{ mA}; V_{CE} = 5\text{ V};$ $f = 100\text{ MHz}$	–	190	–	MHz
$\frac{h_{FE1}}{h_{FE2}}$	DC current gain ratio of the complementary pairs	$ I_C  = 150\text{ mA};  V_{CE}  = 2\text{ V}$	–	1.3	1.6	

NPN power transistors

BD135; BD137; BD139

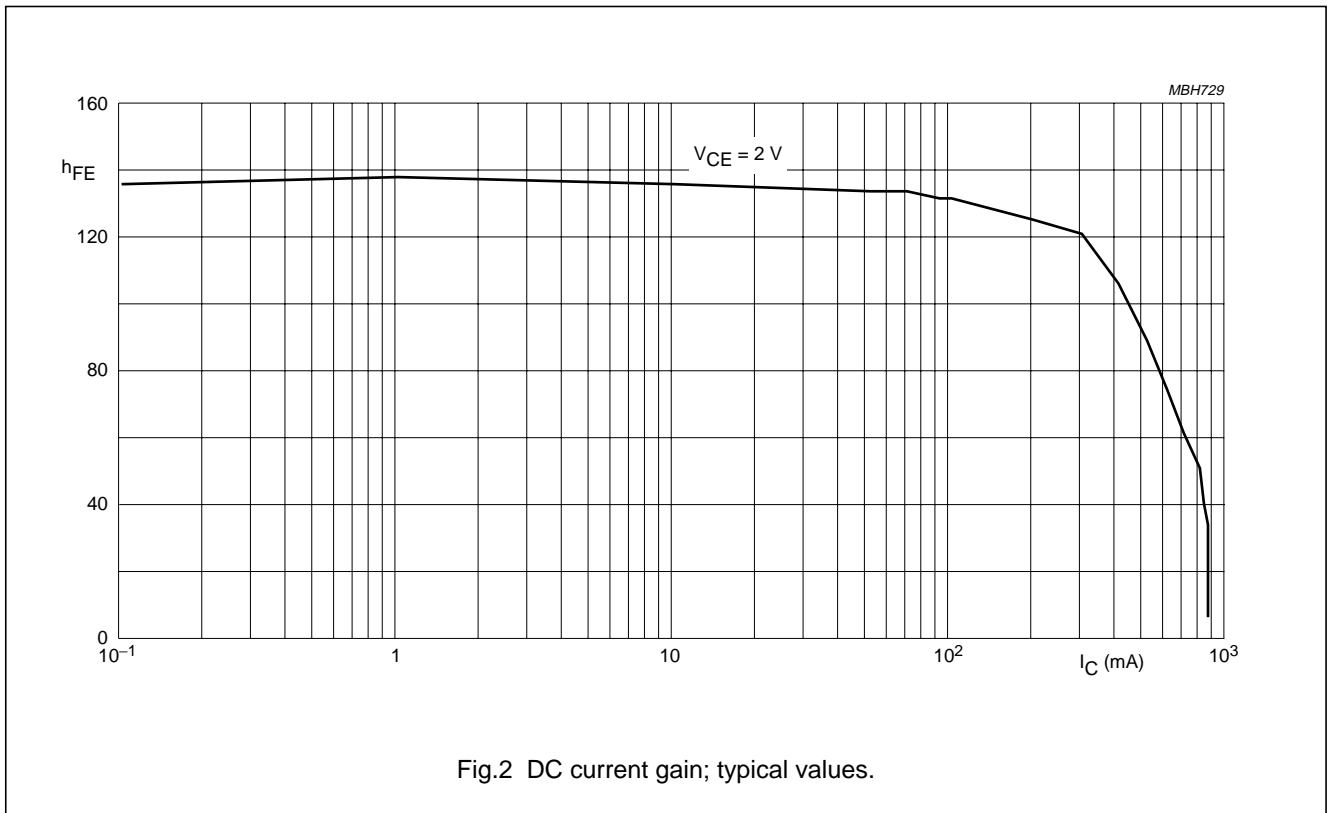

NPN power transistors

BD135; BD137; BD139

PACKAGE OUTLINE

Plastic single-ended leaded (through hole) package; mountable to heatsink, 1 mounting hole; 3 leads SOT32

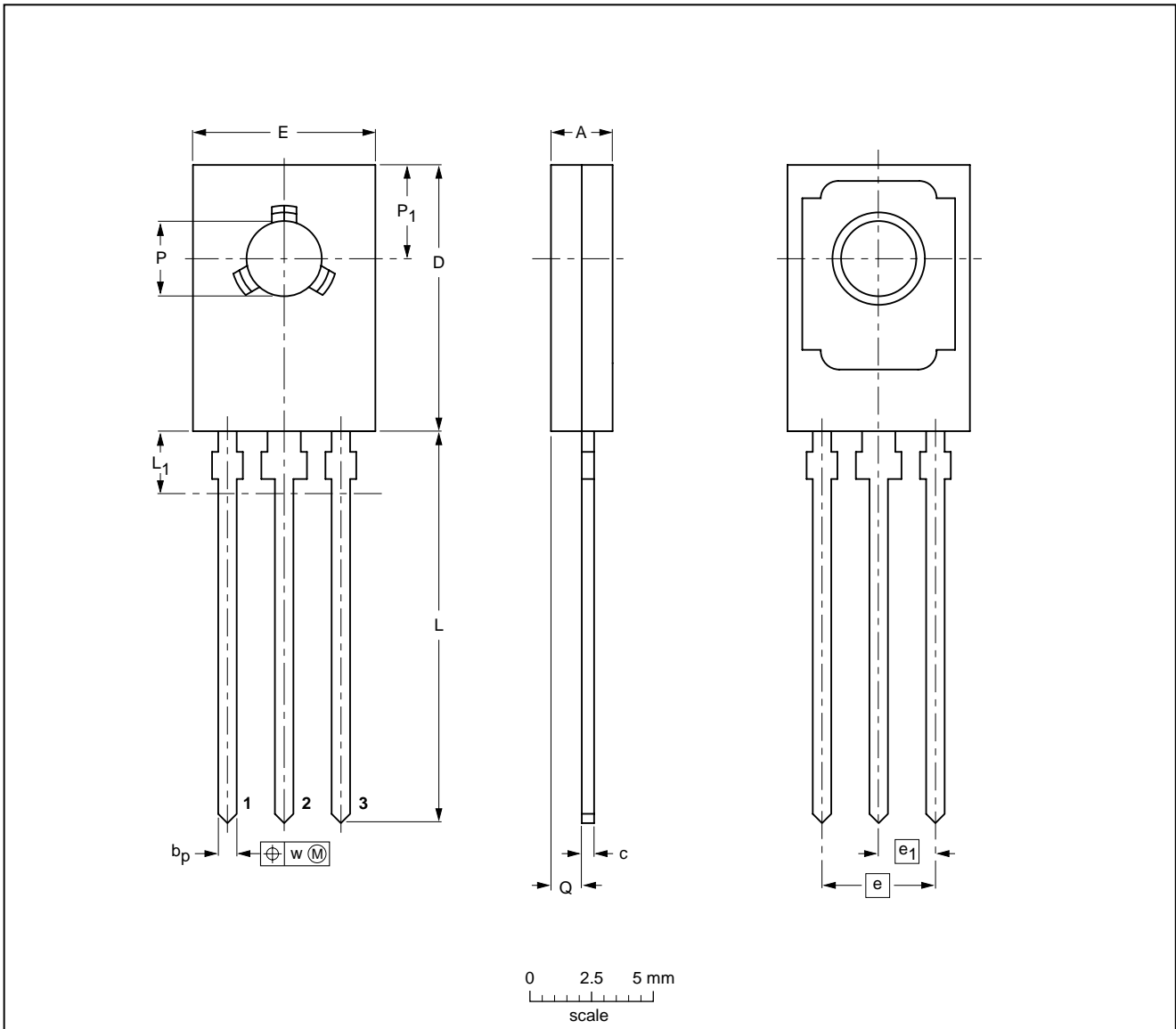

DIMENSIONS (mm are the original dimensions)

UNIT	A	$b_p$	c	D	E	e	$e_1$	L	$L_1^{(1)}$ max	Q	P	$P_1$	w
mm	2.7 2.3	0.88 0.65	0.60 0.45	11.1 10.5	7.8 7.2	4.58	2.29	16.5 15.3	2.54	1.5 0.9	3.2 3.0	3.9 3.6	0.254

Note

1. Terminal dimensions within this zone are uncontrolled to allow for flow of plastic and terminal irregularities.

OUTLINE VERSION	REFERENCES			EUROPEAN PROJECTION	ISSUE DATE
	IEC	JEDEC	EIAJ		
SOT32		TO-126			97-03-04