



TIP140/141/142 TIP145/146/147

COMPLEMENTARY SILICON POWER DARLINGTON TRANSISTORS

- TIP141, TIP142, TIP145 AND TIP147 ARE STMicroelectronics PREFERRED SALESTYPES
- COMPLEMENTARY PNP - NPN DEVICES
- MONOLITHIC DARLINGTON CONFIGURATION
- INTEGRATED ANTIPARALLEL COLLECTOR-EMITTER DIODE

APPLICATIONS

- LINEAR AND SWITCHING INDUSTRIAL EQUIPMENT

DESCRIPTION

The TIP140, TIP141 and TIP142 are silicon Epitaxial-Base NPN power transistors in monolithic Darlington configuration, mounted in TO-218 plastic package. They are intended for use in power linear and switching applications.

The complementary PNP types are TIP145, TIP146 and TIP147 respectively.

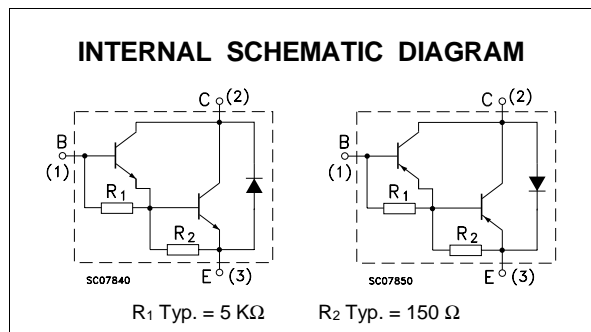
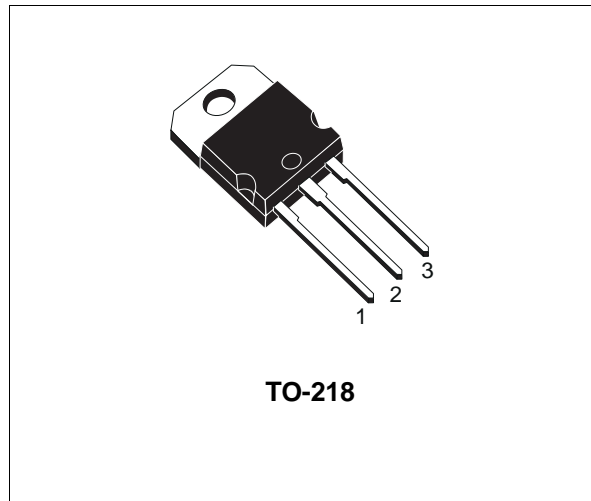

ABSOLUTE MAXIMUM RATINGS

Symbol	Parameter	Value				Unit
		NPN	TIP140	TIP141	TIP142	
		PNP	TIP145	TIP146	TIP147	
V_{CBO}	Collector-Base Voltage ($I_E = 0$)		60	80	100	V
V_{CEO}	Collector-Emitter Voltage ($I_B = 0$)		60	80	100	V
V_{EBO}	Emitter-Base Voltage ($I_C = 0$)			5		V
I_C	Collector Current			10		A
I_{CM}	Collector Peak Current			20		A
I_B	Base Current			0.5		A
P_{tot}	Total Dissipation at $T_{case} \leq 25^\circ C$			125		W
T_{stg}	Storage Temperature			-65 to 150		$^\circ C$
T_j	Max. Operating Junction Temperature			150		$^\circ C$

For PNP types voltage and current values are negative.

TIP140 / TIP141 / TIP142 / TIP145 / TIP146 / TIP147

THERMAL DATA

R _{thj-case}	Thermal Resistance Junction-case	Max	1	°C/W
-----------------------	----------------------------------	-----	---	------

ELECTRICAL CHARACTERISTICS (T_{case} = 25 °C unless otherwise specified)

Symbol	Parameter	Test Conditions	Min.	Typ.	Max.	Unit
I _{CBO}	Collector Cut-off Current (I _E = 0)	for TIP140/145 V _{CB} = 60 V for TIP141/146 V _{CB} = 80 V for TIP142/147 V _{CB} = 100 V			1 1 1	mA mA mA
I _{CEO}	Collector Cut-off Current (I _B = 0)	for TIP140/145 V _{CE} = 30 V for TIP141/146 V _{CE} = 40 V for TIP142/147 V _{CE} = 50 V			2 2 2	mA mA mA
I _{EBO}	Emitter Cut-off Current (I _C = 0)	V _{EB} = 5 V			2	mA
V _{CEO(sus)} *	Collector-Emitter Sustaining Voltage (I _B = 0)	I _C = 30 mA for TIP140/145 for TIP141/146 for TIP142/147	60 80 100			V V V
V _{CE(sat)} *	Collector-Emitter Saturation Voltage	I _C = 5 A I _B = 10 mA I _C = 10 A I _B = 40 mA			2 3	V V
V _{BE(on)} *	Base-Emitter Voltage	I _C = 10 A V _{CE} = 4 V			3	V
h _{FE} *	DC Current Gain	I _C = 5 A V _{CE} = 4 V I _C = 10 A V _{CE} = 4 V	1000 500			
t _{on} t _{off}	RESISTIVE LOAD Turn-on Time Turn-off Time	I _C = 10 A I _{B1} = 40 mA I _{B2} = -40 mA R _L = 3 Ω		0.9 4		μs μs

For PNP types voltage and current values are negative.

* Pulsed: Pulse duration = 300 μs, duty cycle 1.5 %

TO-218 (SOT-93) MECHANICAL DATA

DIM.	mm			inch		
	MIN.	TYP.	MAX.	MIN.	TYP.	MAX.
A	4.7		4.9	0.185		0.193
C	1.17		1.37	0.046		0.054
D		2.5			0.098	
E	0.5		0.78	0.019		0.030
F	1.1		1.3	0.043		0.051
G	10.8		11.1	0.425		0.437
H	14.7		15.2	0.578		0.598
L2	-		16.2	-		0.637
L3		18			0.708	
L5	3.95		4.15	0.155		0.163
L6		31			1.220	
R	-		12.2	-		0.480
Ø	4		4.1	0.157		0.161

