

ГИДРООТВЕТ
доступная гидравлика

内啮合齿轮泵 INTERNAL GEAR PUMP

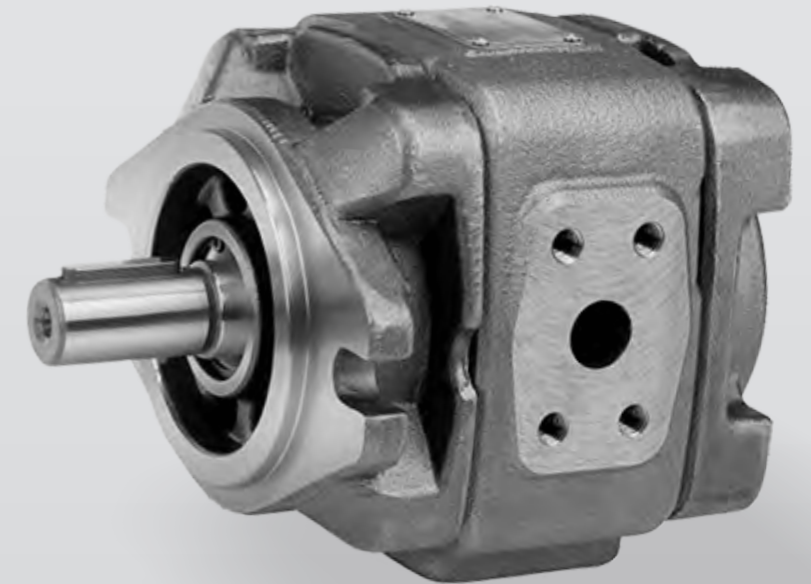

产品简介 / Products Introduction

产品展示 / Product Display



YLH1

YLH2

YLH3



YLH21

YLH22

YLH32

YLH33

YLH series hydraulic pumps are internal gear pumps of clearance compensation with fixed displacement, its advantages are:

- High working pressure——The maximum working pressure is up to 35Mpa.
- High volumetric efficiency——It can maintain high volumetric efficiency even at low rotation speed and low viscosity because of the design of radial and axial pressure compensation devices.
- Low pressure pulsation——Ultra- low flow and pressure pulsation, it can maintain stable flow and pressure output at low speed.
- Low noise——Ultra-low noise, using high strength pump body material and optimization design of internal running parts, even under high pressure, high speed working conditions, it also has low noise.
- Wide speed range——The minimum speed is up to 200 r/min, the maximum speed is up to 3000r/min.
- Strong anti-pollution ability——Not sensitive to oil pollution, long service life.

This series of products are widely applied into the hydraulic system of industries, such as plastic machinery, leather machinery, pressure machinery, metallurgical machinery and forklift truck...especially suitable for the energy saving system of servo frequency conversion drive.

型号说明 / Model Designation

◎ 单泵 ◎ Single Pump

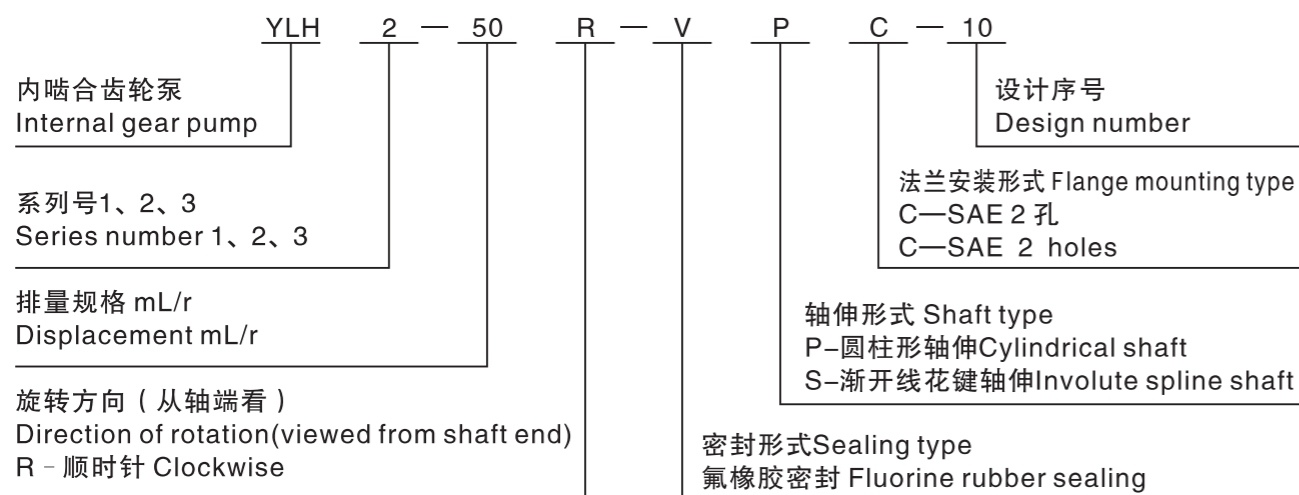

◎ 双联泵 ◎ Double Pump

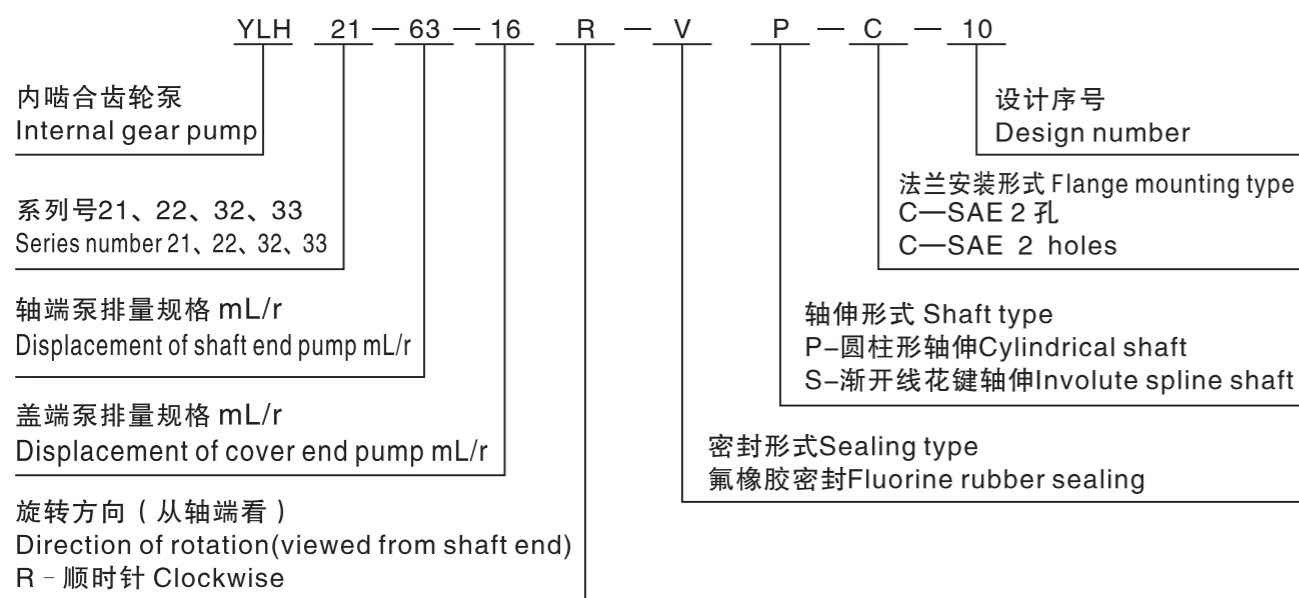

技术参数 / Technical Parameters

◎ 单泵 ◎ Single Pump

系列号 Series No.	规格 Specification	排量 mL/r Displacement	工作压力 MPa Working pressure		转速范围 r/min Rotation speed		重量 Kg Weight
			额定 Rated	最高 Max	最高 Max	最低 Min	
YLH1	8	8.2	31.5	35	3000	600	4.7
	10	10.2					4.9
	13	13.3					5.0
	16	16.0	5.3				
	20	20.0	5.8				
YLH2	25	24.0	25	30	3000	200	6.2
	25	25.3	31.5	35			14.7
	32	32.7					15.5
	40	40.1					16.5
	50	50.7	17.5				
63	63.7	25	30	19			
YLH3	63	64.7	31.5	35	3000	200	42
	80	81.4					43.8
	100	100.2					45.5
	125	125.3	48.8				
	145	145.2	25	28			50.5
	160	162.8	21	26			52.6

◎ 双联泵 ◎ Double Pump

系列号 Series No.	轴端泵排量 Displacement of shaft end pump	盖端泵排量 Displacement of cover end pump
YLH 21	25、32、40、50、63	8、10、13、16、20、25
YLH 22	25、32、40、50、63	25、32、40、50、63
YLH 32	63、80、100、125、145、160	25、32、40、50、63
YLH 33	63、80、100、125、145、160	63、80、100、125、145、160

特性曲线 / Characteristic Curves

流量压力特性 (测试条件: n=1450r/min, v=46mm²/s, t=50°C)

Flow pressure performance: (Testing conditions: n=1450r/min, v=46mm²/s, t=50°C)

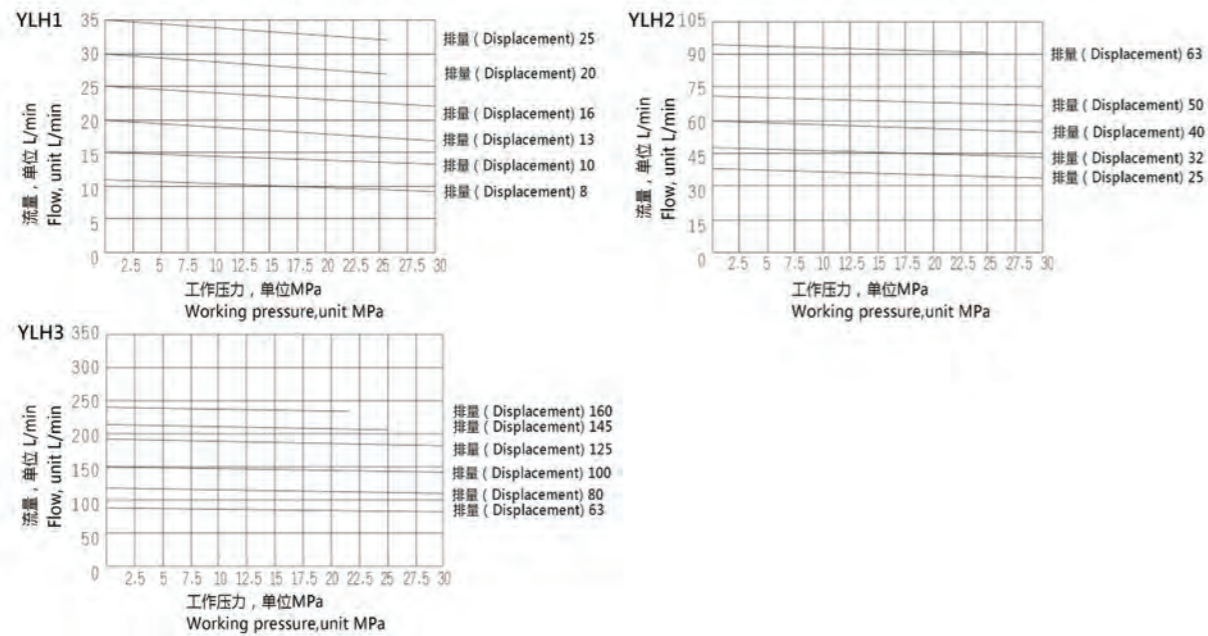

噪音曲线 (测试条件: n=1450r/min, v=46mm²/s, t=50°C 传感器与泵距离=1m)

Noise curves (Testing conditions: n=1450r/min, v=46mm²/s, t=50°C, the distance between sensor and pump=1m)

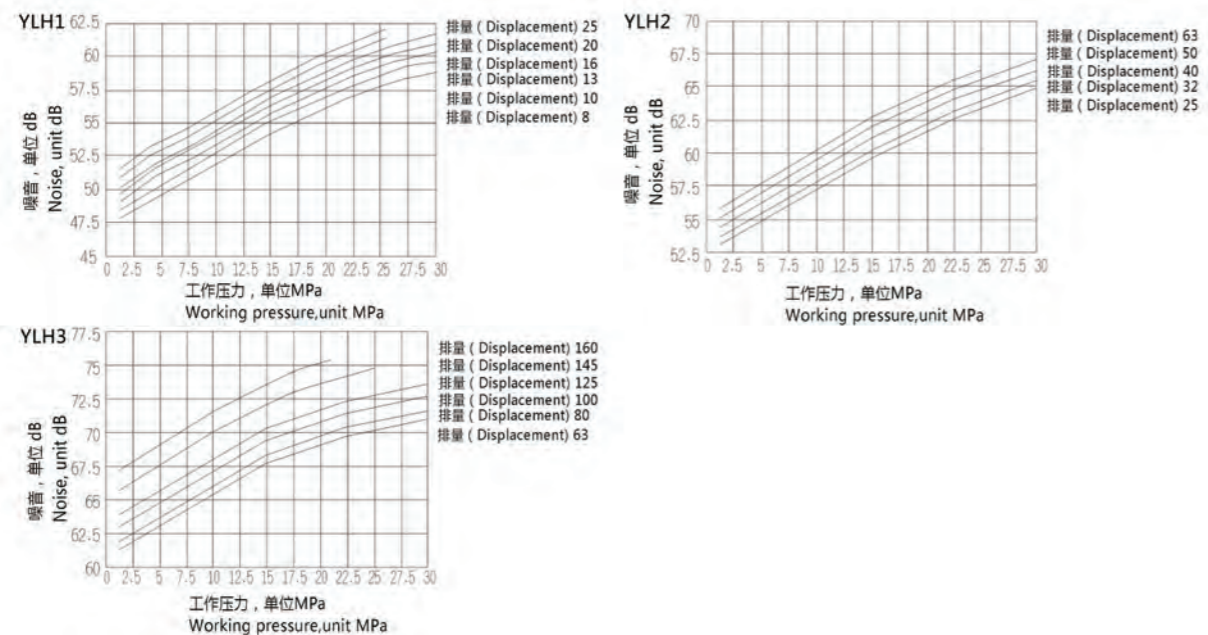

安装联接尺寸 / Installation Connection Dimension

◎ 单泵 ◎ Single Pump

◆ YLH1 ◆

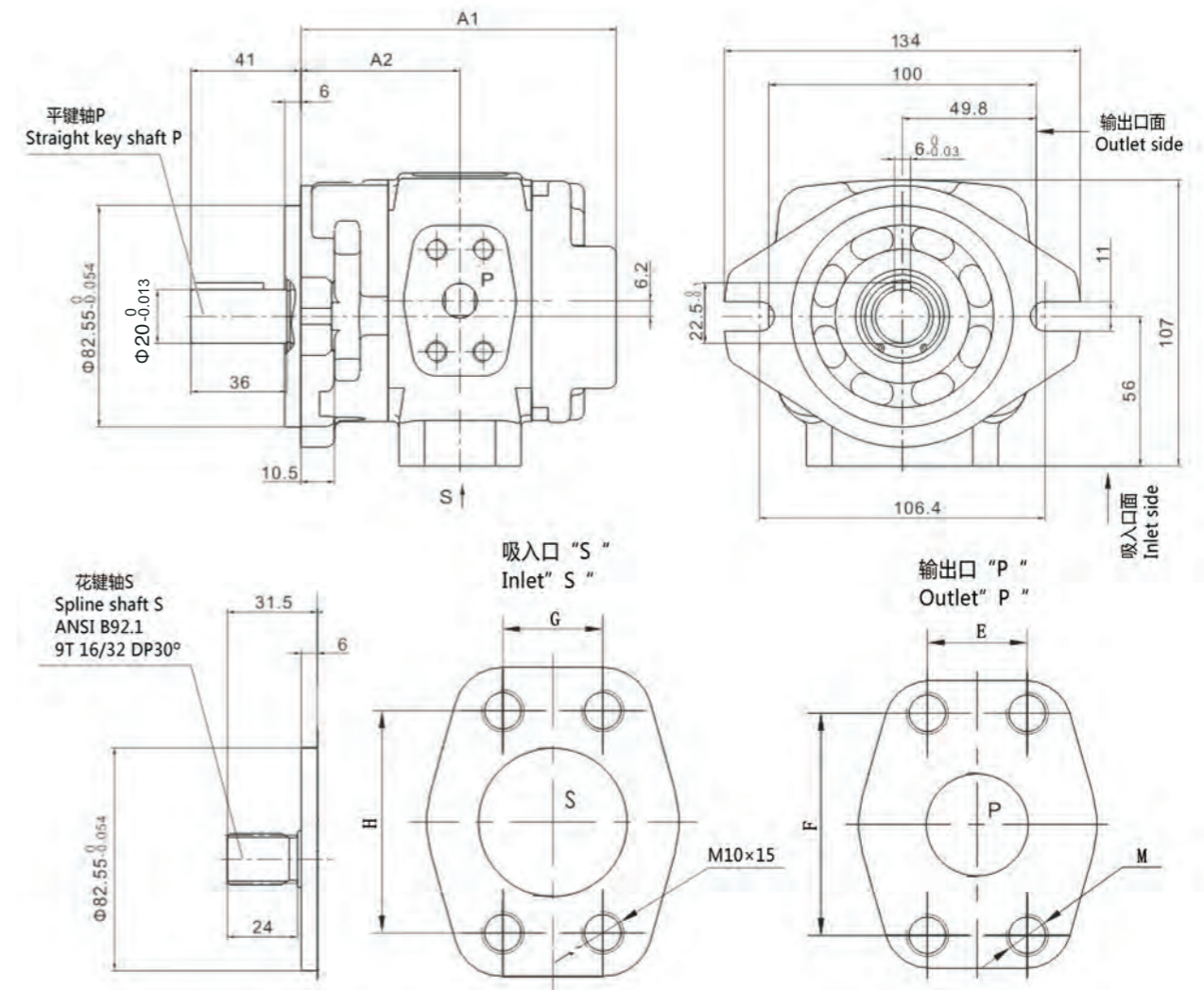

系列号 Series No.	排量 Displacement	A1	A2	S	G×H	P	E×F	M
YLH1	8	108	54	φ 19	22.2x47.6	φ 13	17.5x38.1	M8 × 13
	10	112	56					
	13	118.5	59.5					
	16	124	62.5	30.2x58.7	φ 18	22.2x47.6	M10 × 15	
	20	132	67					
25	140	70	φ 28					

◆ YLH2 ◆

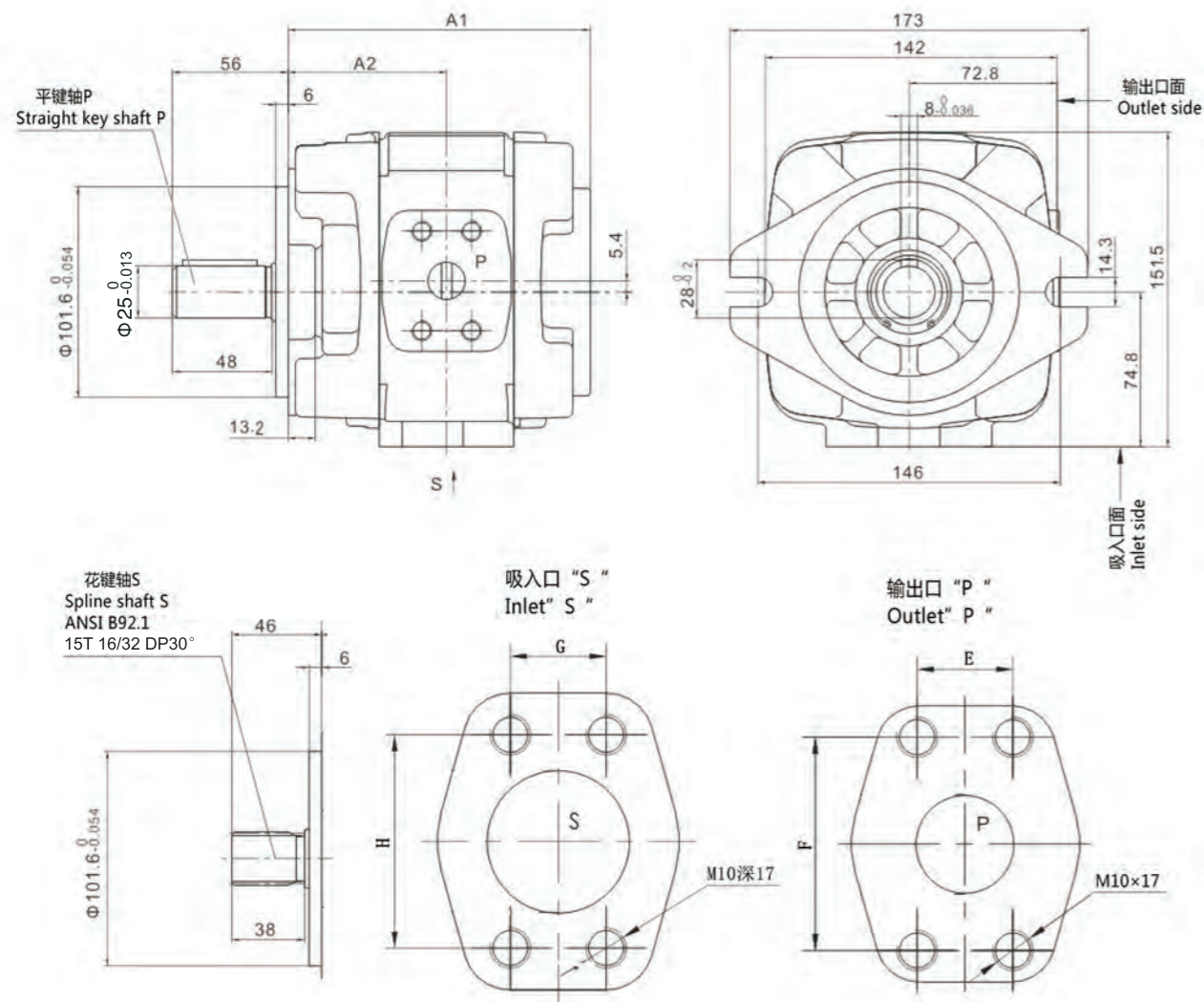

系列号 Series No.	排量 Displacement	A1	A2	S	G × H	P	E × F
YLH2	25	139.5	73	$\Phi 32$	30.2x58.7	$\Phi 18$	22.2x47.6
	32	146.5	76.5				
	40	153.5	80			$\Phi 20$	26.2x52.4
	50	163.5	85				
	63	177.5	92				

◆ YLH3 ◆

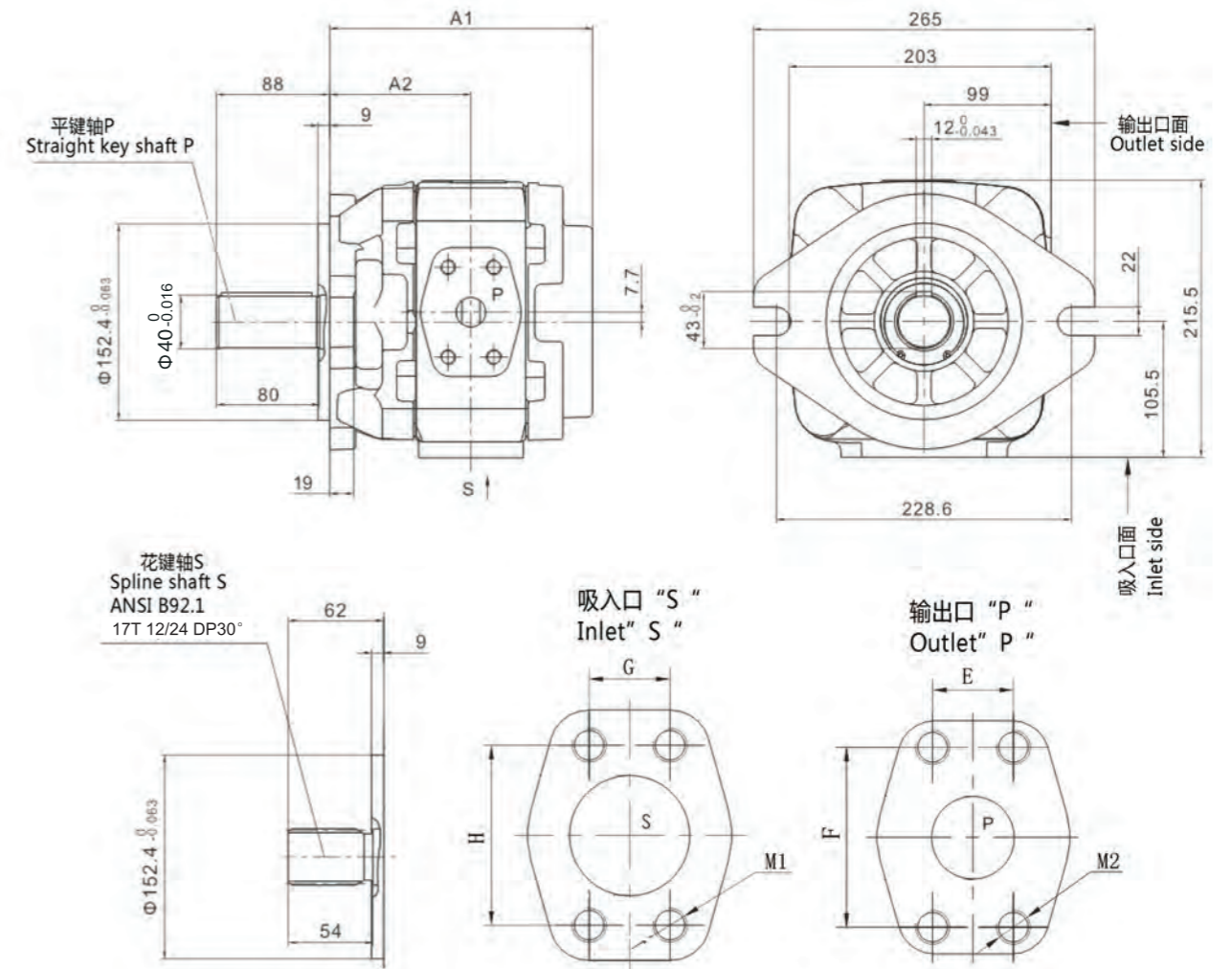

系列号 Series No.	排量 Displacement	A1	A2	S	G × H	M1	P	E × F	M2
YLH3	63	196.5	105.5	$\Phi 40$	35.7x69.9	M12x20	$\Phi 23$	26.2x52.4	M10x17
	80	204.5	109.5	$\Phi 50$	42.9x77.8		$\Phi 32$	35.7x69.9	M12x20
	100	213.5	114	$\Phi 63.5$	50.8x88.9		$\Phi 38$	36.5x79.4	M16x25
	125	225.5	120						
	145	236	124.8						
	160	243.5	129	$\Phi 76$	61.9x106.4		M16x25		

◎ 双联泵 ◎
Double Pump

◆ YLH21 ◆

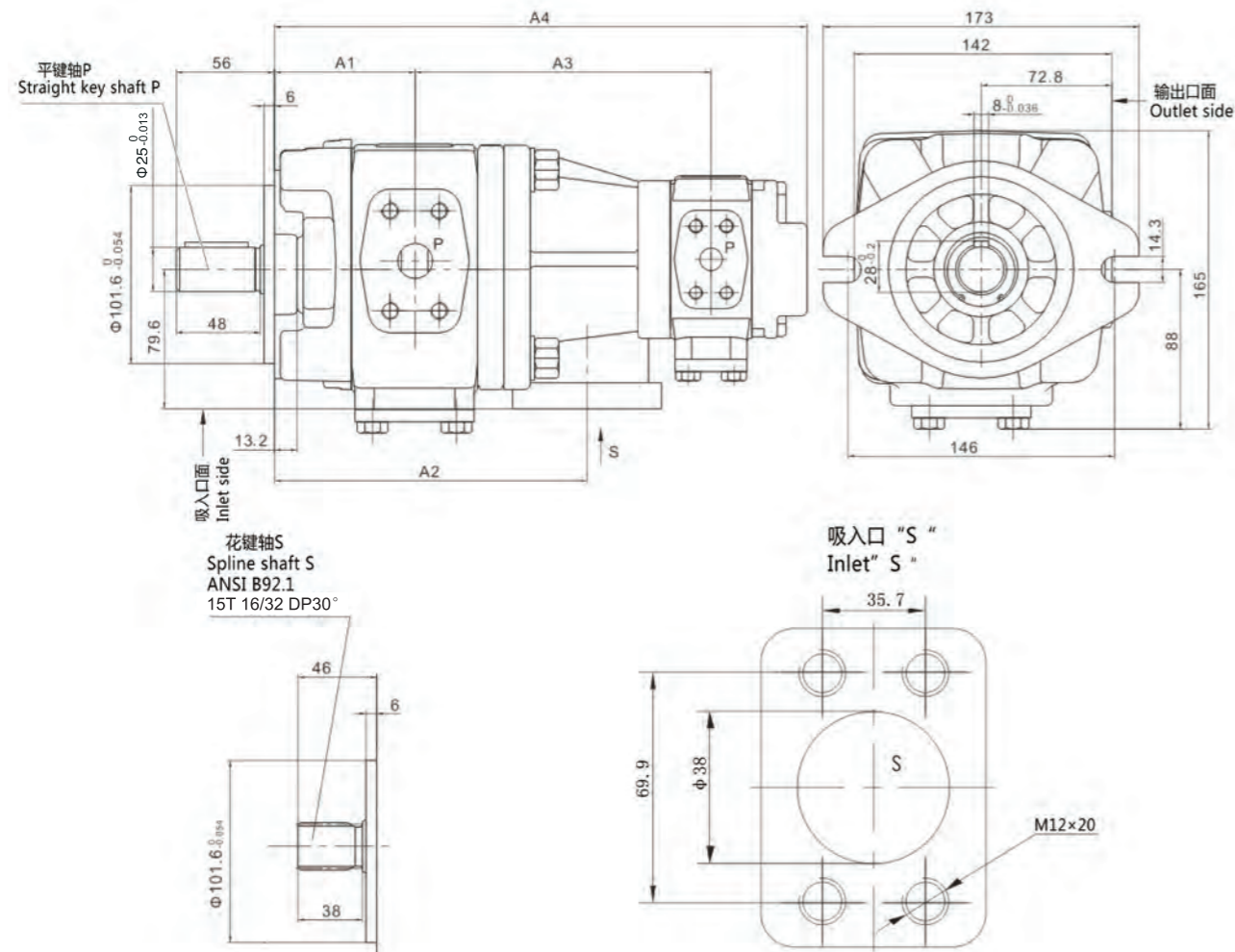

系列号 Series No.	A1	A2	盖端泵规格 Specification of cover end pump											
			8		10		13		16		20		25	
			A3	A4	A3	A4	A3	A4	A3	A4	A3	A4	A3	A4
YLH21-25-※R-※-10	73	153.5	138.5	264.5	140.5	268.5	143.8	275	146.5	280.5	150.5	288.5	154.5	296.5
YLH21-32-※R-※-10	76.5	160.5	142	271.5	144	275.5	147.3	282	150	287.5	154	295.5	158	303.5
YLH21-40-※R-※-10	80	167.5	145.5	278.5	147.5	282.5	150.8	289	153.5	294.5	157.5	302.5	161.5	310.5
YLH21-50-※R-※-10	85	177.5	150.5	288.5	152.5	292.5	155.8	299	158.5	304.5	162.5	312.5	166.5	320.5
YLH21-63-※R-※-10	92	191.5	157.5	302.5	159.5	306.5	162.8	313	165.5	318.5	169.5	326.5	173.5	334.5

注：输出口法兰连接尺寸参照相应单泵输出口“P”。

Note: The connection dimensions of the outlet flange refer to the corresponding single pump outlet "P".

◆ YLH22 ◆

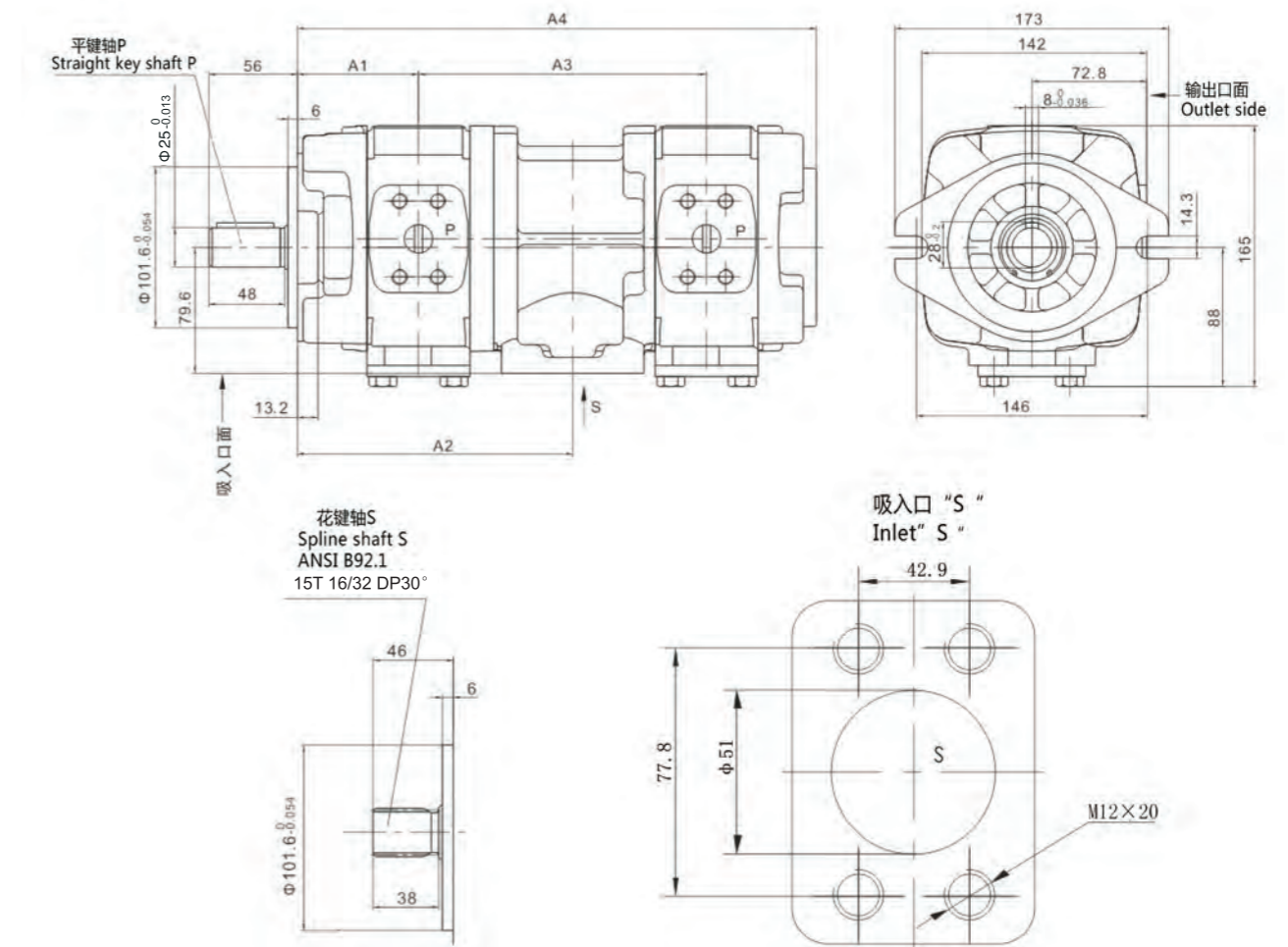

系列号 Series No.	A1	A2	盖端泵规格 Specification of cover end pump										
			25		32		40		50		63		
			A3	A4	A3	A4	A3	A4	A3	A4	A3	A4	
YLH22-25-※R-※-10	73	161	161	300									
YLH22-32-※R-※-10	76.5	168	164.5	307	168	314							
YLH22-40-※R-※-10	80	175	168	314	171.5	321	175	328					
YLH22-50-※R-※-10	85	185	173	324	176.5	331	180	338	185	448			
YLH22-63-※R-※-10	92	199	180	338	183.5	345	187	352	192	362	199	376	

注：输出口法兰连接尺寸参照相应单泵输出口“P”。

Note: The connection dimensions of the outlet flange refer to the corresponding single pump outlet "P".

◆ YLH32 ◆

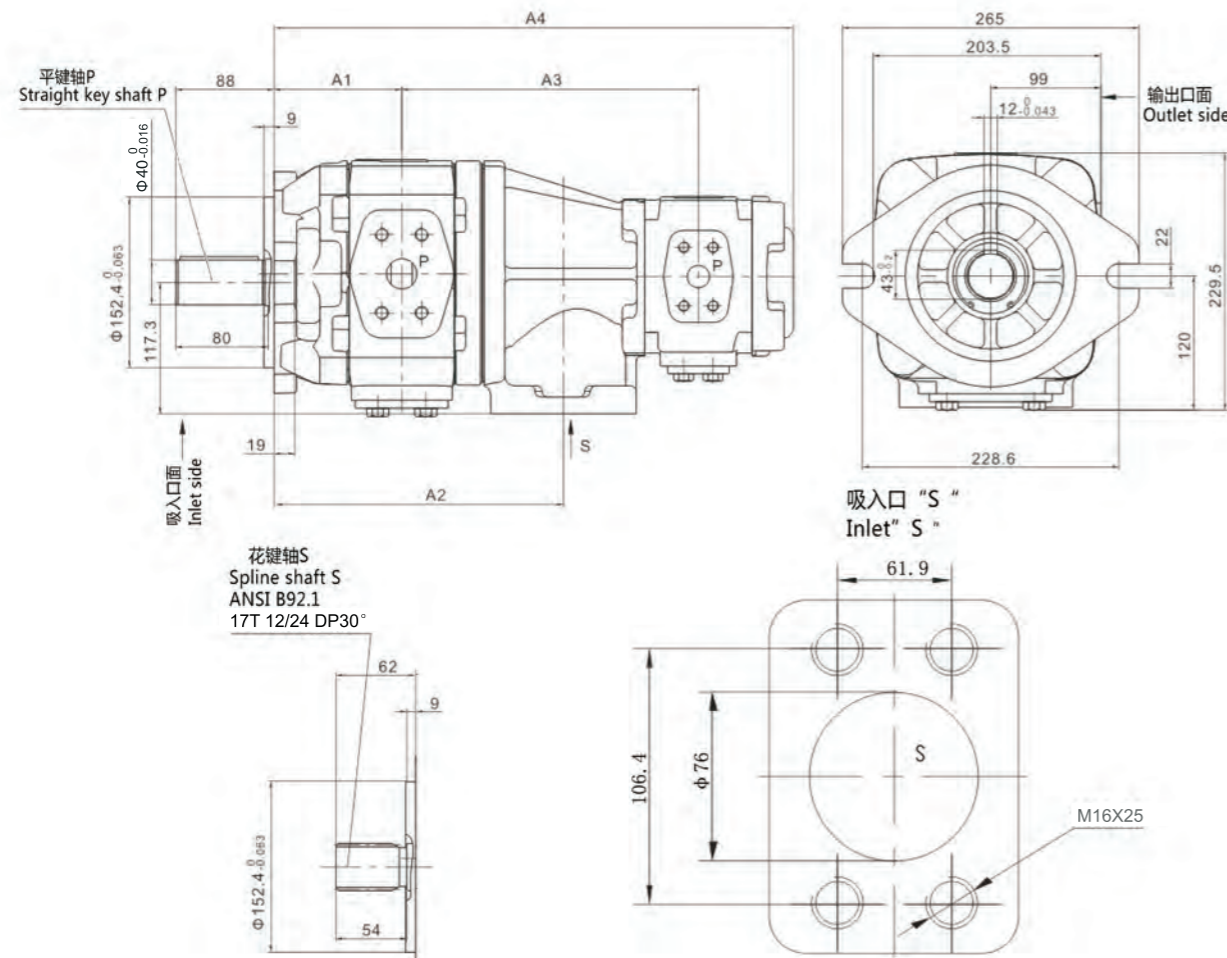

系列号 Series No.	A1	A2	盖端泵规格 Specification of cover end pump									
			25		32		40		50		63	
			A3	A4	A3	A4	A3	A4	A3	A4	A3	A4
YLH32-63-※R-※-10	105.5	223	200.5	372	204	379	207.5	386	212.5	396	219.5	410
YLH32-80-※R-※-10	109.5	231	204.5	380	208	387	211.5	394	216.5	404	223.5	418
YLH32-100-※R-※-10	114	240	209	389	212.5	396	216	403	221	413	228	427
YLH32-125-※R-※-10	120	252	215	401	218.5	408	222	415	227	425	234	439
YLH32-145-※R-※-10	124.8	261.5	219.8	410.5	223.3	417.5	226.8	424.5	231.8	434.5	238.8	448.5
YLH32-160-※R-※-10	129	270	224	419	227.5	426	231	433	236	443	243	457

注：出口法兰连接尺寸参照相应单泵出口“P”。

Note: The connection dimensions of the outlet flange refer to the corresponding single pump outlet "P".

◆ YLH33 ◆

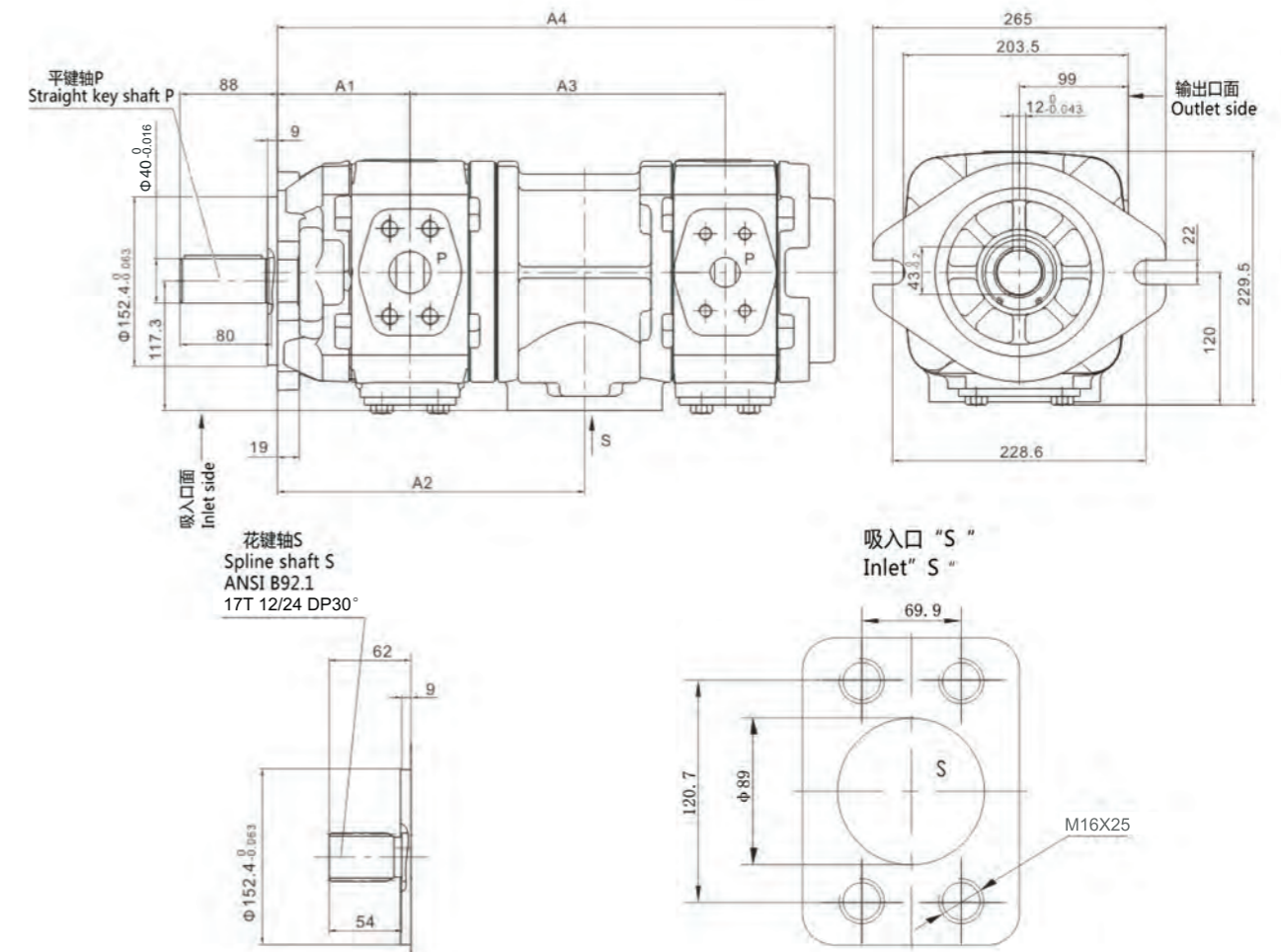

系列号 Series No.	A1	A2	盖端泵规格 Specification of cover end pump											
			63		80		100		125		145		160	
			A3	A4	A3	A4	A3	A4	A3	A4	A3	A4	A3	A4
YLH33-63-※R-※-10	105.5	230.5	225	421										
YLH33-80-※R-※-10	109.5	238.5	229	429	233	437								
YLH33-100-※R-※-10	114	247.5	233.5	438	237.5	446	242	455						
YLH33-125-※R-※-10	120	259.5	239.5	450	243.5	458	248	467	254	479				
YLH33-145-※R-※-10	124.8	269	244.3	459.5	248.3	467.5	252.8	476.5	258.8	488.5	263.5	498		
YLH33-160-※R-※-10	129	277.5	248.5	468	251.5	476	257	485	263	497	268.3	506.5	272	515

注：出口法兰连接尺寸参照相应单泵出口“P”。

Note: The connection dimensions of the outlet flange refer to the corresponding single pump outlet "P".

■ Notes for Use of Oil Pump

1. Hydraulic oil

- Petroleum-based mineral oil with a viscosity range of 10~300mm²/s is available, ISO VG46 or ISO VG68 anti-wear hydraulic oil is recommended.
- Do not mix different brands of hydraulic oil together, as this may cause the breakdown of the oil and deterioration of lubrication quality.
- Cleanliness of oil: The grade of pollution degree of solid particles in the oil shall not be higher than grade 9 in NAS 1638 or 17/14 in ISO4066.
- Change the oil regularly according to the running condition, and clean up the residue in the oil tank at the a same time.

2. Operating temperature

- Operating temperature range: -10~80°C, to ensure long-term reliable life, the optimal operating temperature range is 20~60°C.

3. Oil tank

- The capacity of the oil tank should match the operating condition of the pump, that is , ensure the oil suction pipe port and oil return pipe port should always be under the oil tank fluid surface, especially in the most severe cases(e.g., all hydraulic cylinders in the system are protruding in the outermost position), this condition must also be ensured.
- The oil temperature of the oil tank shall not exceed the allowed oil temperature, a cooler may be provided if necessary.

4. Suction pressure and piping

- Select the inner diameter of the pipe according to the oil port of the pump (The optimal suction inlet flow velocity is 0.6~1.2m/s.)
- The suction inlet pressure is 0.8~2 bar absolute pressure.
- Try to avoid rigid connection of inlet and outlet tubing with steel pipe. It is recommended to use rubber hose to avoid extra noise caused by extra load.
- Thoroughly clean pipes and pipe joints before assembly.
- The return oil can not be sucked directly into the pump in any case, that is, the oil return pipe and the oil suction pipe shall be kept as far as possible.
- The oil suction pipe and the oil return pipe should always be immersed under the oil surface.
- Be sure there is no leakage of pipe assembly.
- The drain tubes under two type of instructions shall be used, as shown in figure below. In this way, even if the hydraulic oil in the suction pipe is drawn out, there will be oil inside the pump to supplement.



5. The filter

- It is recommended to use return oil filter or pressure filter. If using suction inlet filter, it must be equipped with vacuum switch or contamination indicator.
- The basic requirement of suction inlet filter is above 150 mesh.

6. Oil pump installation and concentricity

- The drive shaft of the pump is not allowed to have radial force and axial force, it should use the coupling which can compensate the deviation of two center lines.
- Avoid axial force when installing coupling, it is forbidden to install by knock or strong pressure method.
- The concentricity numerical value of the pump shaft and the motor shaft is the specified numerical value as shown in the figure below (the eccentricity error shall be less than 0.05mm).

When machining the coupling, pay special attention to the concentricity of the outside diameter and inside diameter of the coupling.

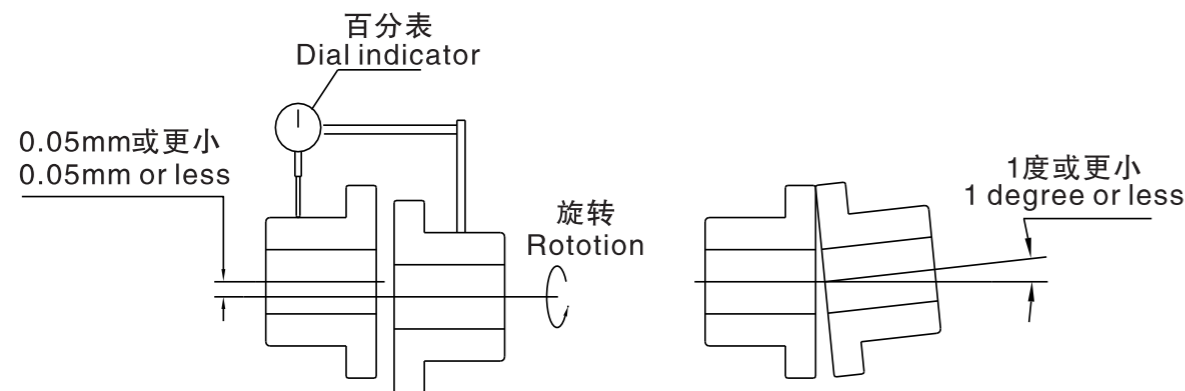

Under the condition of connection using flange cover:

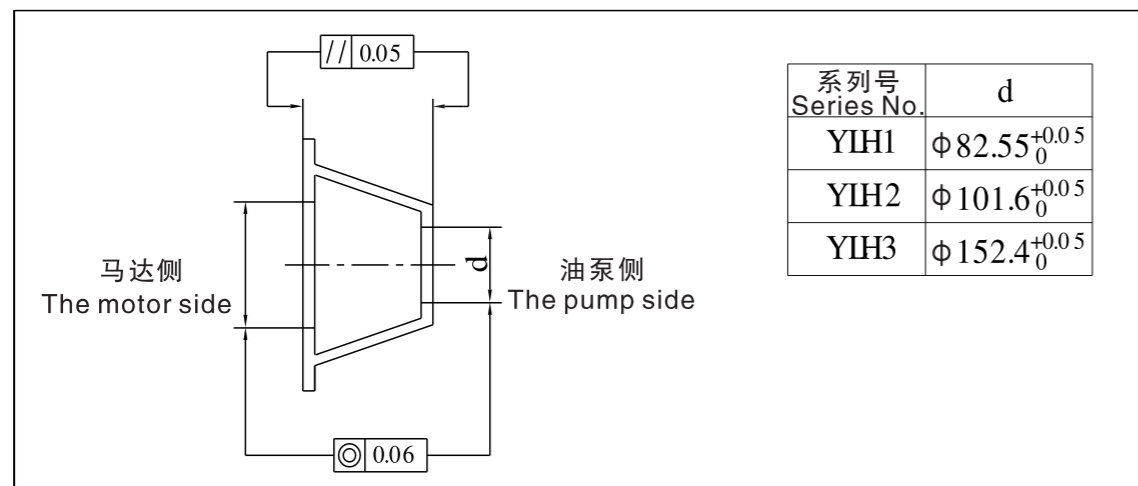

7. Matters needing attention during initial operation

a) Initial startup check

- Check whether the hydraulic unit is correct and installed carefully.
- Check whether the turning direction is correct. (viewed from shaft end is clockwise direction.)

b) Initial startup

- Before the initial operation, the pump should be fully filled with oil to ensure the safety of operation and prevent wear caused by improper installation. Never operate a pump without oil.
- After confirming the hydraulic oil has been injected into the pump chamber, open the safety valve in the outlet pipeline, discontinuously run the motor under without load condition, ensure the oil pump is fully lubricated, and discharge the air in the pipeline. (If no air release valve is set in the system, the outlet connection of pump can also be slightly relaxed, resulting in a little leakage of the method for exhaust. **Note: when using this method, it must be in low pressure state, and ensure the pressure will not rise.**)
- It can't start loading, otherwise it will cause damage inside the oil pump.
- After repeated inching operation, the sound of air suction will disappear. Please run continuously after the air is mixed into the pipeline and the sound disappears. If the air is mixed into the pipeline, and the sound doesn't disappear after several times inching operation, there should be air leakage in the pipeline of the inlet side.

8. Continuous operation

a) Rated pressure, Maximum pressure

- Rated pressure: Pressure for continuous operation.
- Maximum pressure: The maximum pressure must be less than 1/3 of the operating one cycle of the system, and the maximum pressure can last for up to 20 seconds. The rated pressure/Maximum pressure of different displacement specifications is different. For details, please refer to the list of pump performance parameters.

b) Using speed

The operating speed of oil pumps with different displacement specifications is different. For details, please refer to the list of pump performance parameters.

9. Disassembly and repair

All oil pumps have been tested for performance and function before they leave the factory. Any enterprise or individual shall not disassemble, reassemble or modify the oil pumps without permission of the company.

Disassembly, reassembly and modification without the company's permission are not covered by the company's warranty, and the company shall not assume any responsibility.