



I-8024W-G

4-channel 14-bit Analog Output Module

System Specifications

Model	I-8024W
LED Indicators/Display	
System LED Indicator	1 LED as Power Indicator
I/O LED Indicator	-
Isolation	
Intra-module Isolation, Field-to-Logic	2500 VDC
EMS Protection	
ESD (IEC 61000-4-2)	±4 kV Contact for Each Terminal
Power	
Power Consumption	2 W Max.
Mechanical	
Dimensions (W x L x H)	30 mm x 102 mm x 115 mm
Environment	
Operating Temperature	-25 ~ +75 °C
Storage Temperature	-40 ~ +85 °C
Humidity	10 ~ 90% RH, Non-condensing

I/O Specifications

Model	I-8024W
Analog Output	
Channels	4
Current Output Wiring	Sink
Range	±10 VDC, 0 ~ +20 mA
Resolution	14-bit
Accuracy	
Voltage	±0.1% of FSR
Current	±0.2% of FSR
Readback Accuracy	±1% of FSR
Zero Drift	
Voltage	±30 μV/ °C
Current	±0.2 μA/ °C
Span Drift	±20 ppm/°C
Voltage Output Capability	10 VDC @ 20 mA
Max. Current Load Resistance	External +24 VDC: 1050 Ω

Ordering Information

I-8024W-G CR	4-channel 14-bit Analog Output Module (Gray Cover) (RoHS)
---------------------	---

Features

- 4-channel Voltage or Current Output
- Individual Channel Configuration
- ±4 kV ESD Protection
- 2500 Vdc Intra-module Isolation
- Wide Operating Temperature Range: -25 ~ +75 °C



Introduction

The I-8024W is a 14-bit Analog Output Module, which offers 4 single-ended analog output channels. Each channel can be programmed to an individual output range of ±10 VDC or 0 ~ +20 mA. The I-8024W provides RF immunity level matching that defined by IEC 61000-4-3 standard, together with ±4 kV ESD protection as well as 2500 Vdc intra-module isolation.

Internal I/O Structure

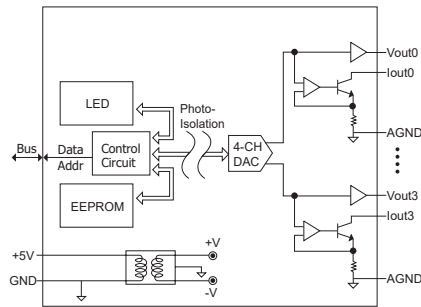

Wire Connections

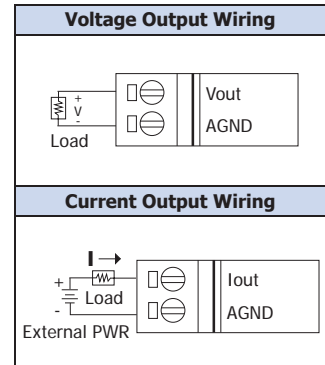

Dimensions (Units: mm)

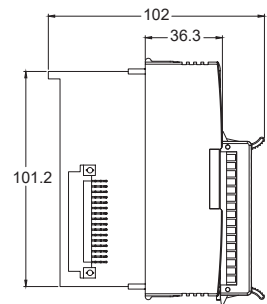

Left View

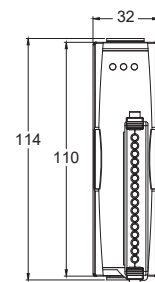

Front View

Pin Assignments

