

Bandpass filters «BPF-6»

"BPF-6" unit is a bandpass filter with 6 bands support and built-in RF amplifier and ATT. This bandpass filters can be used with popular amateur transceivers "Druzhba", "Desna", "Druzhba-M", "Rosa", "Klopik", "Sloboda" and others. Bandpass filters are double circuit and switches by relays 12V or 27V. PCB dimensions are 124x55 mm. There are five connectors (X1–X5) for connection to the transceiver.

Coils of bandpass filter are assembled on skeleton forms 6 mm with trimming ferrite cores. The winding of the bands of 1.9 MHz and 3.5 MHz should be assembled in sections, the other bands – winding turn to turn. The data of winding and the values of the capacitors are shown below. For optimal consumption of the wire use the column "Length of wire". This is estimated comfortable length of wire to finish the coil and cut the ends. For L1&L4 comfortable length of wire is 15cm.

KT815, KT646

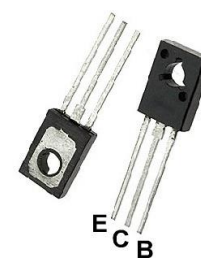

Band	L2 & L3	Wire, mm	L1 & L4	Wire	C1 & C2	C3
1,9 MHz	40 turns	0.1-0.2	6 turns	0.1-0.2 mm	820 pF	36-39 pF
3,5 MHz	27 turns	0.1-0.2	3.5 turns	0.1-0.2 mm	470 pF	30-33 pF
7 MHz	21 turns	0.1-0.2	3 turns	0.1-0.2 mm	220 pF	7.5-8.2 pF
14 MHz	16 turns	0.3 mm	2.5 turns	0.1-0.2 mm	100 pF	4.7-5.0 pF
21 MHz	10 turns	0.5mm	2 turns	0.1-0.2 mm	91 pF	4.7-5.0 pF
28 MHz	10 turns	0.5mm	1.5 turns	0.1-0.2 mm	56 pF	4.7-5.0 pF
Transformer Tp1	toroid K10x6x5	two twisted wires 0.3mm	7 turns			

RF Amplifier (RFA) is transistor KT646, the load of which is auto-transformer Tp1.

RF Amplifier (RFA) is ON only in the "RX" mode through relays P16 and P17 via Switcher on the front panel of the transceiver. In the TX mode RF Amplifier automatically switches OFF.

Stepped attenuator 20 dB is assembled on the resistor links. The attenuator control is a switcher on the front panel of the transceiver, the resistor link regulates by the contacts of relays P13, P14.

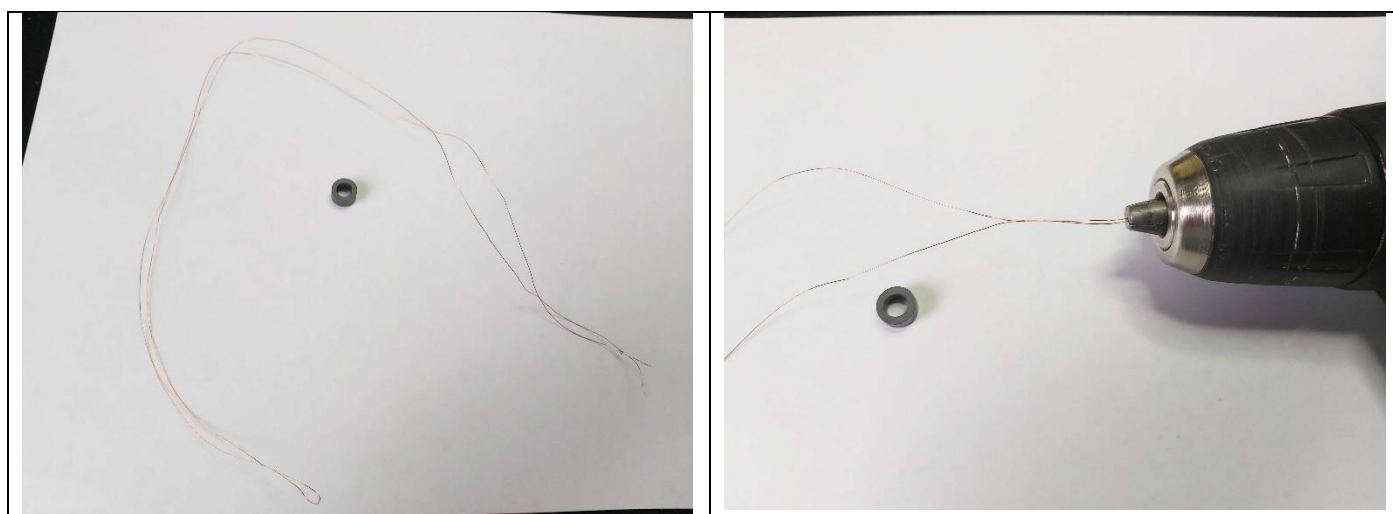

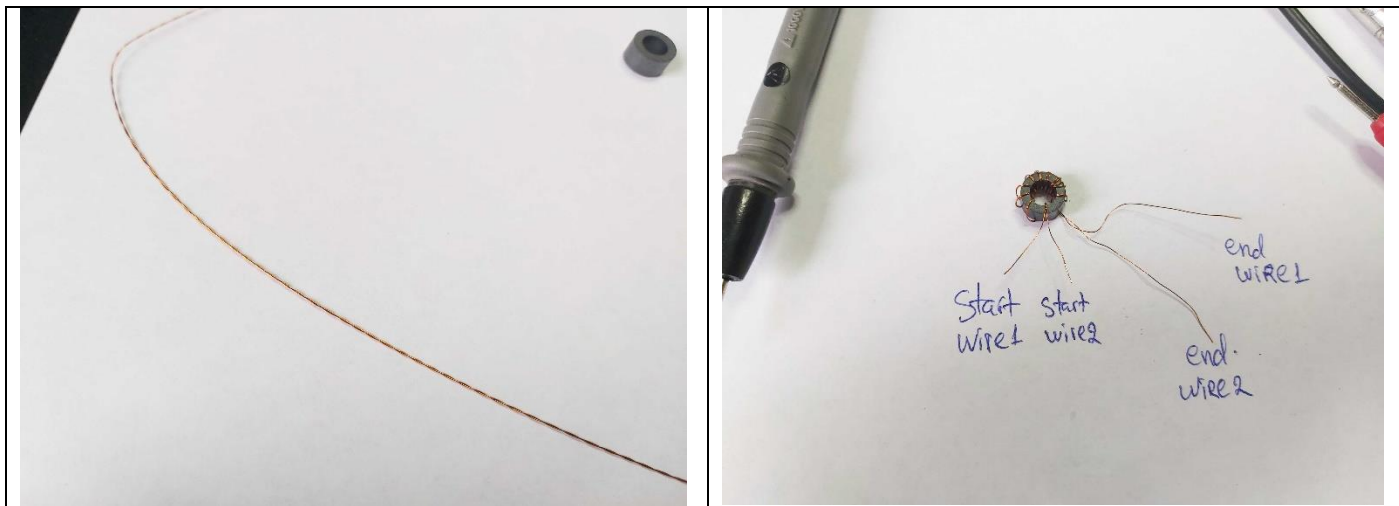

Connectors

Connector	PIN 1	PIN 2	PIN 3	PIN 4	PIN 5	PIN 6	PIN 7
X1	+12V HFA	Corpus	28 MHz	24 MHz	21 MHz	18 MHz	14 MHz
X2	1,9 MHz	3,5 MHz	7 MHz	10 MHz	+12V TX	-12V ATT	
X3	GND	Input	GND				
X4	GND	To main board	GND				
X5	GND	To input "PA"	GND				

Adjustment

RF generator and voltmeter (or S-meter) is necessary devices for adjustment of BPF-6. Adjustment should be done on each band via tuning the RF generator. With proper adjustment, which is achieved by tuning of coils up and down from the boundaries of the bands, the readings of the S-meter with a constant voltage of RF generator must be changed to more than 10-20 μA (if full scale of S-meter is 100 μA).

The current through the transistor KT646 must be equal to 20-25 μA . AFC of RF Amplifier could be corrected on 10m band via the choosing the capacitors in emitter circuit.

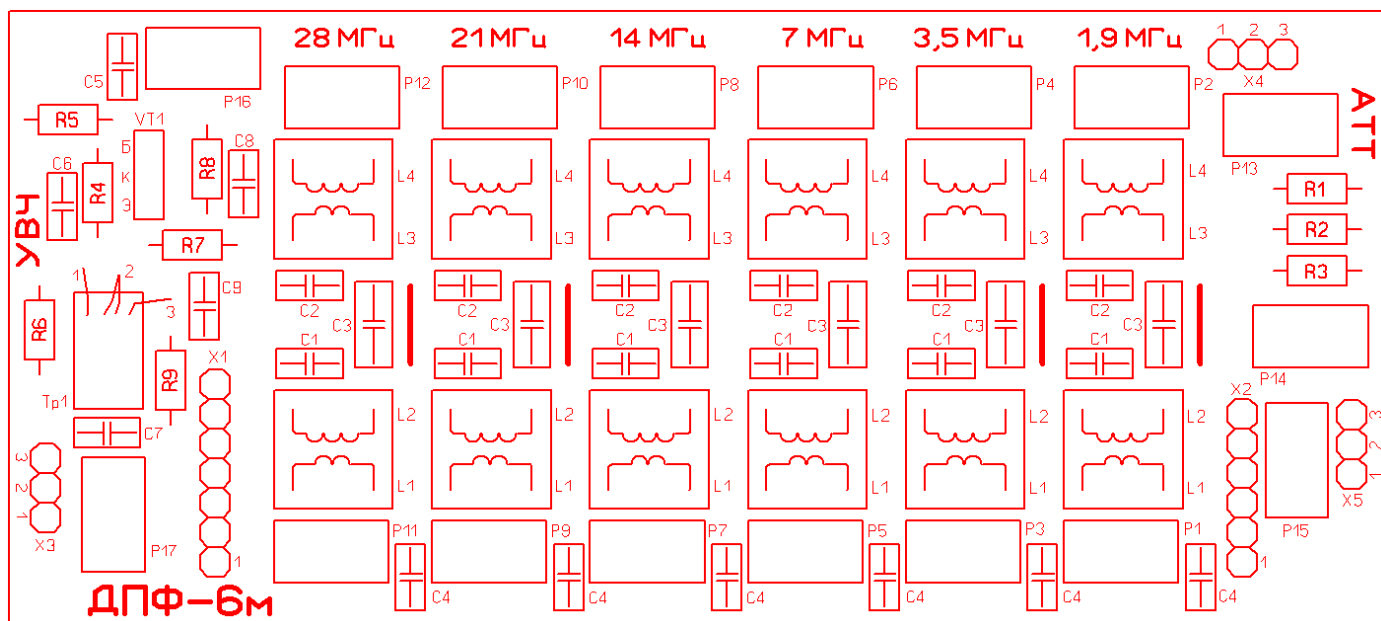

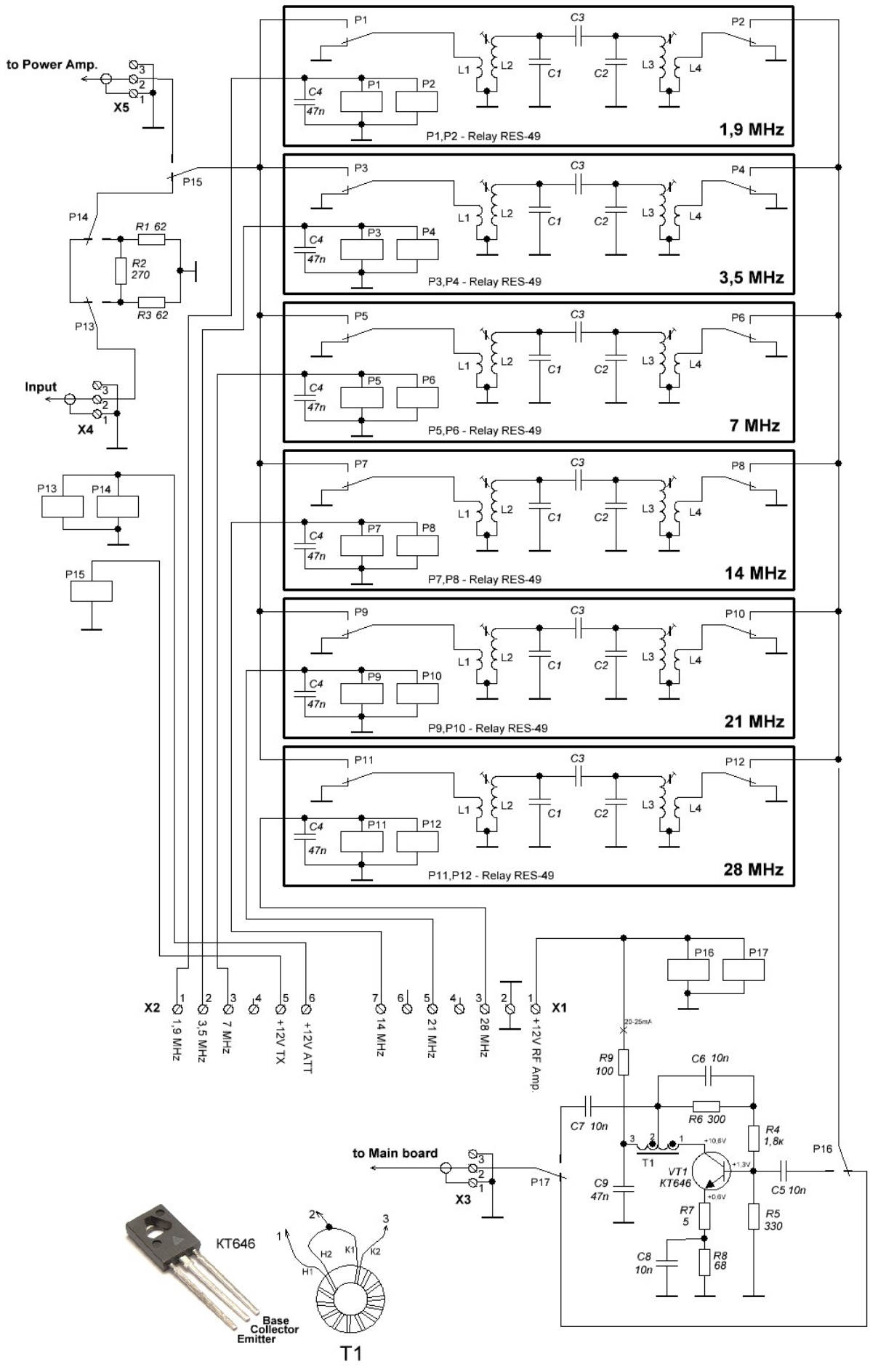

Coil building Recommendations

1. The building of coils requires special care and deliberation, and, importantly, good hand motility. The plastic frames are quite fragile. Soldering the leads is recommended to be done by quickly touching the soldering iron - do not hold for a long time, because the plastic will begin to melt and the lead can be lost from the frame.
2. Multi-section frames have 5 sections. Accordingly, to wind 40 turns for a range of 160 meters, eight turns must be wound in each section. And for the range of 80 meters 27 turns. In the first two sections we place six turns, in the rest five. Before soldering, the ends of the wire must be stripped of varnish insulation and pre-tinned with a soldering iron. Solder the ends to the frame leads and wind the secondary winding approximately in the middle of the frame.
3. One-section frames are wound coil-to-coil. Temporarily fasten the ends of the wires to the terminals of the frame with a small twist of 2-3 turns. Further, it is recommended to process the winding with BF-2 or BF-6 glue to fix the winding. Leave to dry for 1-2 hours; other coils can be made at this time. After the glue has dried, it is necessary to carefully clean the ends of the wires, and solder them to the frame leads. Make a secondary winding in the middle of the frame, glue, dry, clean the ends and solder to the frame leads. The frame is ready for mounting on the board.