

AN7205, AN7205S

FM Front-end Circuit (3V Operation)

Overview

The AN7205 and AN7205S are the FM front-end circuit most suitably designed for 3V operating radio and radio cassette recorder, and characteristics against strong input signal is improved.

High sensitive series can be realized by the combination with FM-AM IF IC (AN7221S) and MPX IC (AN7421).

Features

- Good inter modulation characteristics
- Frequency drift of local oscillator is small for the variation of power supply.
- Good AM-rejection characteristics
- High sensitivity

Pin Descriptions

Pin No.	AN7205	AN7205S
1	RF Input	RF Input
2	RF By-pass Capacitor	RF By-pass Capacitor
3	RF Output	RF Output
4	Mix. Input	Mix. Input
5	GND	GND
6	Mix. Output	Mix. Output
7	OSC.	OSC.
8	OSC.	V _{CC}
9	V _{CC}	—

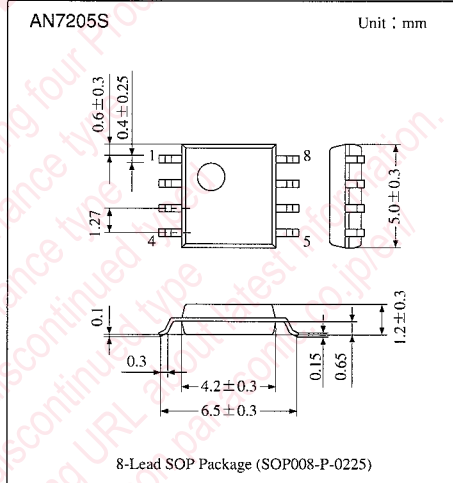
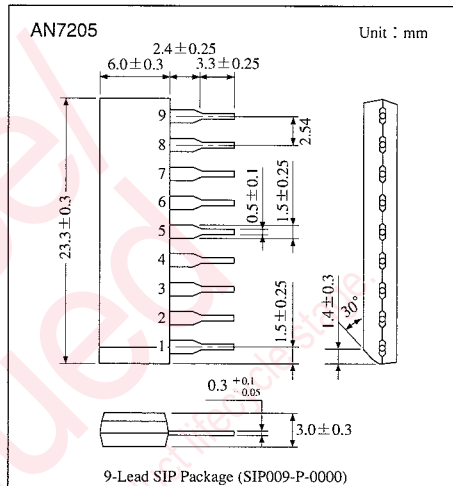

ICs for Tuner

Block Diagrams

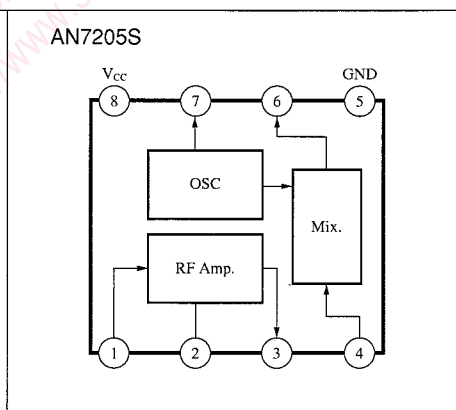
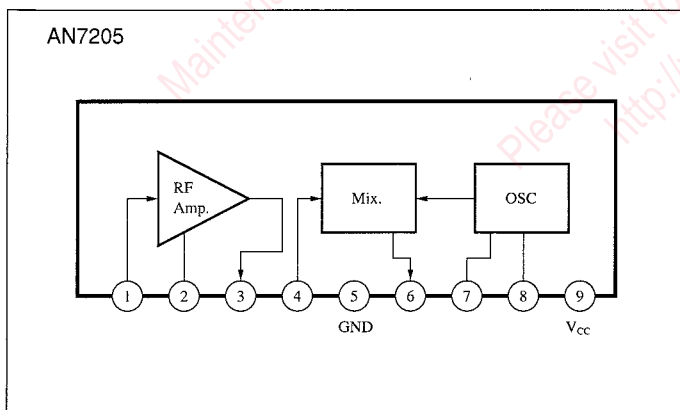

■ Absolute Maximum Ratings (Ta=25°C)

Parameter	Symbol	Rating	Unit	
Supply Voltage	V _{CC}	7	V	
Supply Current	I _{CC}	13	mA	
Power Dissipation	P _D	100	mW	
Operating Ambient Temperature	T _{opr}	-20 ~ +75	°C	
Storage Temperature	AN7205	T _{stg}	-55 ~ +150	°C
	AN7205S			

■ Recommended Operating Range (Ta=25°C)

Parameter	Symbol	Range
Operating Supply Voltage Range	V _{CC (opr)}	1.5 ~ 7V

■ Electrical Characteristics (Ta=25°C)

Parameter	Symbol	Condition	min.	typ.	max.	Unit
Total Circuit Current	I _{tot}	V _{CC} =3V, No signal	3.50	—	8.25	mA
Output Voltage	V _O *	V _{CC} =3V, V _{in} =55dBμ, 106MHz	10.6	—	25.6	mV
Local Oscillation Voltage	V _{OSC}	V _{CC} =1.5V, f _{osc} =116.7MHz	72.8	—	—	mV

* Maximum output value should be read by changing input signal frequency by 106MHz ± Δf.

■ Characteristics Curve

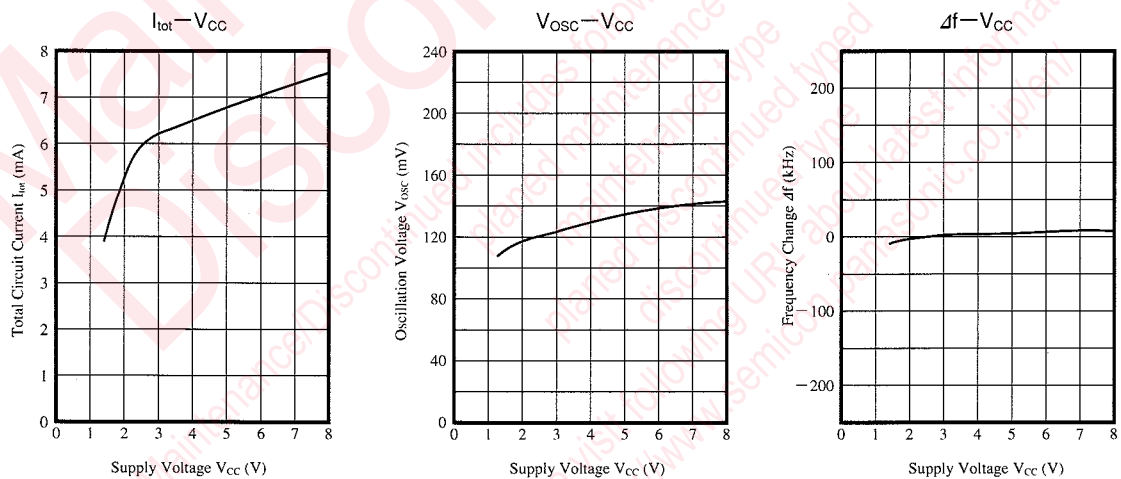

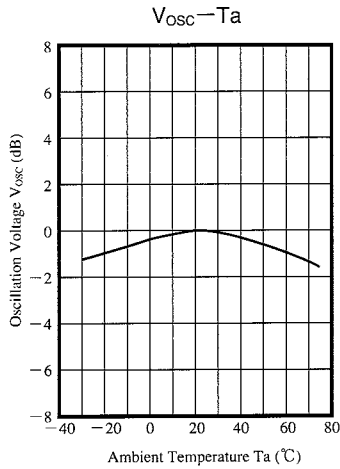

■ Application Circuit

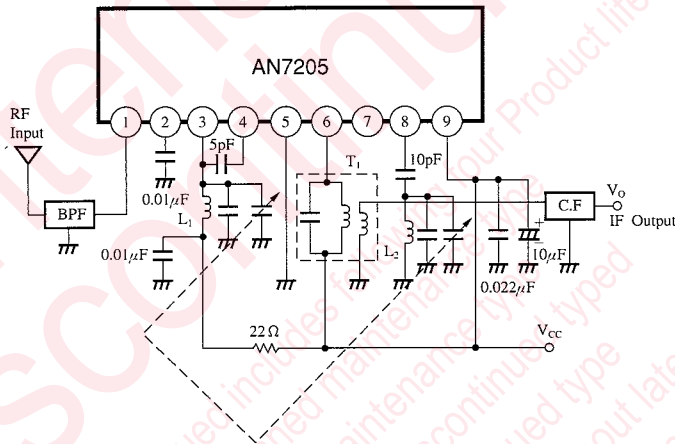

ICs for Tuner

■ Coil Specifications

Symbol	Use, Freq.	Type No.	Maker	Connection Diagram	Number of Turns	L Value/ C Value	Unloaded Q
L ₁	RF Coil		OE INDUSTRY		4T Space Winding	0.102μH f=25.2MHz	77 f=25.2MHz
L ₂	OSC Coil		OE INDUSTRY		3T Space Winding	0.086μH f=25.2MHz	73 f=25.2MHz
T ₁	FM IFT 10.7MHz	IFT-41K9	MITSUMI		①-②7T ②-③4T ④-⑥2T	110pF	100

- Band pass filter : SOSHIN DENKI BPWB 5
- Variable capacitor : MITSUMI PVC-2LXT-L

■ Printed Circuit Board Layout

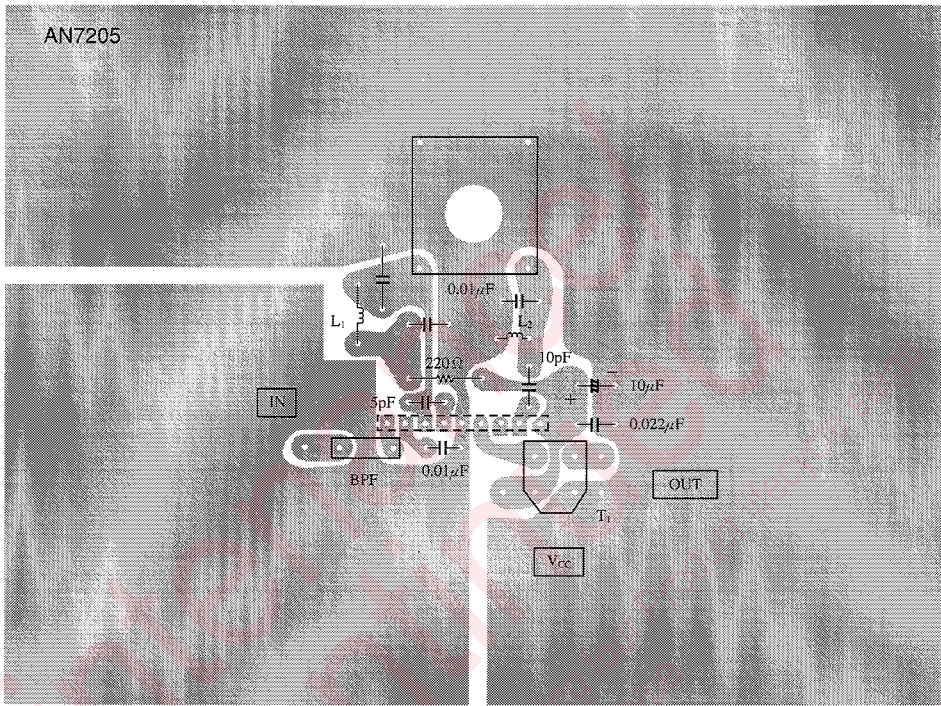

Request for your special attention and precautions in using the technical information and semiconductors described in this book

- (1) If any of the products or technical information described in this book is to be exported or provided to non-residents, the laws and regulations of the exporting country, especially, those with regard to security export control, must be observed.
- (2) The technical information described in this book is intended only to show the main characteristics and application circuit examples of the products. No license is granted in and to any intellectual property right or other right owned by Panasonic Corporation or any other company. Therefore, no responsibility is assumed by our company as to the infringement upon any such right owned by any other company which may arise as a result of the use of technical information described in this book.
- (3) The products described in this book are intended to be used for standard applications or general electronic equipment (such as office equipment, communications equipment, measuring instruments and household appliances).
Consult our sales staff in advance for information on the following applications:
 - Special applications (such as for airplanes, aerospace, automobiles, traffic control equipment, combustion equipment, life support systems and safety devices) in which exceptional quality and reliability are required, or if the failure or malfunction of the products may directly jeopardize life or harm the human body.
 - Any applications other than the standard applications intended.
- (4) The products and product specifications described in this book are subject to change without notice for modification and/or improvement. At the final stage of your design, purchasing, or use of the products, therefore, ask for the most up-to-date Product Standards in advance to make sure that the latest specifications satisfy your requirements.
- (5) When designing your equipment, comply with the range of absolute maximum rating and the guaranteed operating conditions (operating power supply voltage and operating environment etc.). Especially, please be careful not to exceed the range of absolute maximum rating on the transient state, such as power-on, power-off and mode-switching. Otherwise, we will not be liable for any defect which may arise later in your equipment.
 - Even when the products are used within the guaranteed values, take into the consideration of incidence of break down and failure mode, possible to occur to semiconductor products. Measures on the systems such as redundant design, arresting the spread of fire or preventing glitch are recommended in order to prevent physical injury, fire, social damages, for example, by using the products.
- (6) Comply with the instructions for use in order to prevent breakdown and characteristics change due to external factors (ESD, EOS, thermal stress and mechanical stress) at the time of handling, mounting or at customer's process. When using products for which damp-proof packing is required, satisfy the conditions, such as shelf life and the elapsed time since first opening the packages.
- (7) This book may be not reprinted or reproduced whether wholly or partially, without the prior written permission of our company.