Transil™, transient voltage surge suppressor (TVS)

Datasheet – production data

Features

- Peak pulse power: 600 W (10/1000 μ s)
- Stand-off voltage range 6.8 to 440 V
- Unidirectional and bidirectional types
- Low clamping factor
- Fast response time
- UL recognized

Complies with the following standards

- IEC 61000-4-2 level 4
 - 15 kV (air discharge)
 - 8 kV (contact discharge)
- MIL STD 883G, method 3015-7 Class 3
 - HBM (human body model)

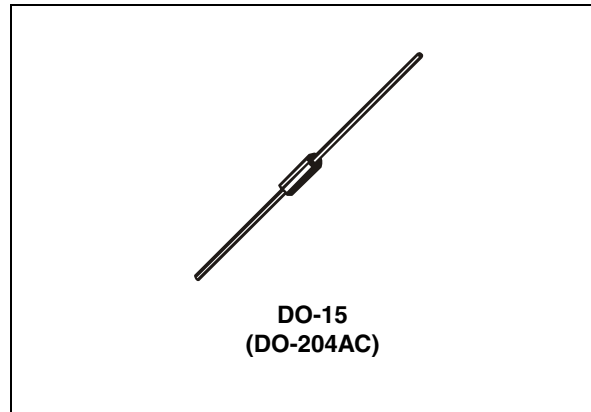
**Description**

Transil diodes provide high overvoltage protection by clamping action. Their instantaneous response to transient overvoltages makes them particularly suited to protect voltage sensitive devices such as MOS Technology and low voltage supplied IC's.

TM:Transil is a trademarks of STMicroelectronics.

1 Characteristics

Table 1. Absolute maximum ratings ($T_{amb} = 25\text{ }^\circ\text{C}$)

Symbol	Parameter	Value	Unit
P_{PP}	Peak pulse power dissipation ⁽¹⁾	$T_{j\text{ initial}} = T_{amb}$ 600	W
P	Power dissipation on infinite heatsink	$T_{amb} = 75\text{ }^\circ\text{C}$ 5	W
I_{FSM}	Non repetitive surge peak forward current for unidirectional types	$t_p = 10\text{ ms}$ $T_{j\text{ initial}} = T_{amb}$ 100	A
T_{stg}	Storage temperature range	-65 to + 175	$^\circ\text{C}$
T_j	Maximum operating junction temperature	175	$^\circ\text{C}$
T_L	Maximum lead temperature for soldering during 10 s at 5 mm from case.	260	$^\circ\text{C}$

1. For a surge greater than the maximum values, the diode will fail in short-circuit.

Table 2. Thermal resistances

Symbol	Parameter	Value	Unit
$R_{th(j-l)}$	Junction to leads	20	$^\circ\text{C/W}$
$R_{th(j-a)}$	Junction to ambient on printed circuit. $L_{lead} = 10\text{ mm}$	75	

Figure 1. Electrical characteristics - definitions

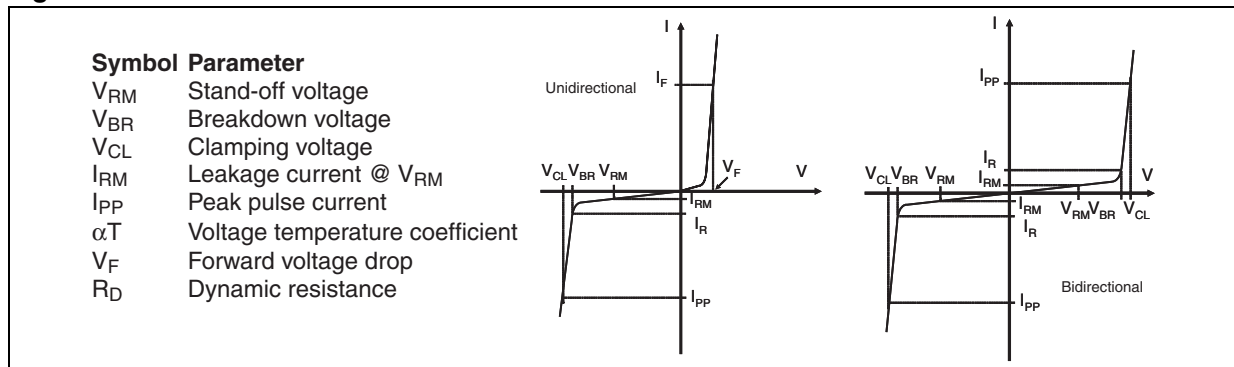

Figure 2. Pulse definition for electrical characteristics

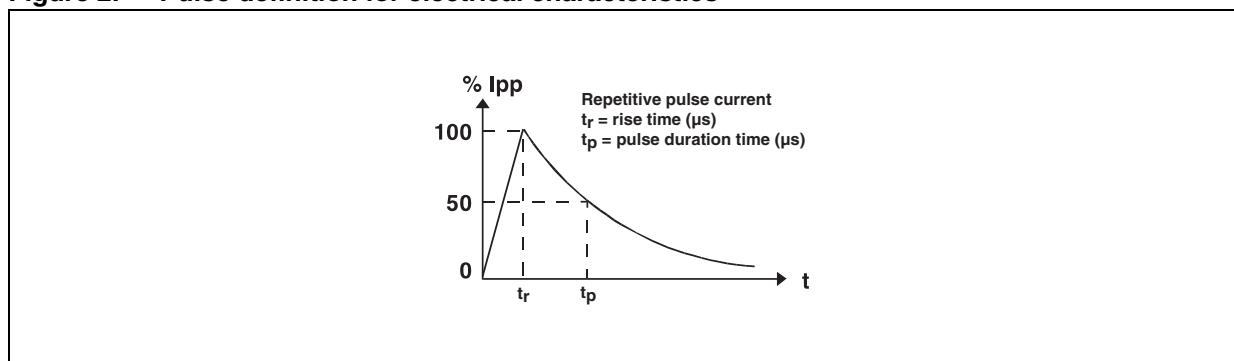

Table 3. Electrical characteristics - values ($T_{amb} = 25\text{ }^{\circ}\text{C}$)

Order code		$I_{RM} @ V_{RM}^{(1)}$		$V_{BR} @ I_R^{(2)}$				$V_{CL} @ I_{PP} 10/1000\ \mu\text{s}$		$V_{CL} @ I_{PP} 8/20\mu\text{s}$		$\alpha T^{(3)}$	$C^{(4)}$
		max		min	nom	max		max		max		max	typ
Unidirectional	Bidirectional	μA	V	V	V	V	mA	V	A	V	A	$10^{-4}/^{\circ}\text{C}$	pF
P6KE6V8A	P6KE6V8CA	10	5.8	6.45	6.8	7.14	10	10.5	57	13.4	298	5.7	4000
P6KE7V5A	P6KE7V5CA	10	6.4	7.13	7.5	7.88	10	11.3	53	14.5	276	6.1	3700
P6KE10A	P6KE10CA	1	8.55	9.5	10	10.5	1	14.5	41	18.6	215	7.5	2800
P6KE12A	P6KE12CA	0.5	10	11.4	12	12.6	1	16.7	36	21.7	184	7.8	2300
P6KE15A	P6KE15CA	0.5	13	14.3	15	15.8	1	21.2	28	27.2	147	8.4	1900
P6KE18A	P6KE18CA	0.5	15	17.1	18	18.9	1	25.2	24	32.5	123	8.8	1600
P6KE22A	P6KE22CA	0.5	19	20.9	22	23.1	1	30.6	20	39.3	102	9.2	1350
P6KE24A	P6KE24CA	0.5	20	22.8	24	25.2	1	33.2	18	42.8	93	9.4	1250
P6KE27A	P6KE27CA	0.5	23	25.7	27	28.4	1	37.5	16	48.3	83	9.6	1150
P6KE30A	P6KE30CA	0.5	26	28.5	30	31.5	1	41.5	14.5	53.5	75	9.7	1075
P6KE33A	P6KE33CA	0.5	28	31.4	33	34.7	1	45.7	13.1	59	68	9.8	1000
P6KE36A	P6KE36CA	0.5	31	34.2	36	37.8	1	49.9	12	64.3	62	9.9	950
P6KE39A	P6KE39CA	0.5	33	37.1	39	41.0	1	53.9	11.1	69.7	57	10.0	900
P6KE47A	P6KE47CA	0.5	40	44.7	47	49.4	1	64.8	9.3	84	48	10.1	800
P6KE56A	P6KE56CA	0.5	48	53.2	56	58.8	1	77	7.8	100	40	10.3	700
P6KE68A	P6KE68CA	0.5	58	64.6	68	71.4	1	92	6.5	121	33	10.4	625
P6KE82A	P6KE82CA	0.5	70	77.9	82	86.1	1	113	5.3	146	27	10.5	550
P6KE100A	P6KE100CA	0.5	85	95.0	100	105	1	137	4.4	178	22.5	10.6	500
P6KE120A	P6KE120CA	0.5	102	114	120	126	1	165	3.6	212	19	10.7	450
P6KE150A	P6KE150CA	0.5	128	143	150	158	1	207	2.9	265	15	10.8	400
P6KE180A	P6KE180CA	0.5	154	171	180	189	1	246	2.4	317	12.6	10.8	360
P6KE200A	P6KE200CA	0.5	171	190	200	210	1	274	2.2	353	11.3	10.8	350
P6KE220A	P6KE220CA	0.5	188	209	220	231	1	328	1.85	388	10.3	10.8	330
P6KE250A	P6KE250CA	0.5	213	237	250	263	1	344	1.75	442	9	11	310
P6KE300A	P6KE300CA	0.5	256	285	300	315	1	414	1.45	529	7.6	11	290
P6KE350A	P6KE350CA	0.5	299	332	350	368	1	482	1.25	618	6.5	11	270
P6KE400A	P6KE400CA	0.5	342	380	400	420	1	548	1.1	706	5.7	11	360
P6KE440A	P6KE440CA	0.5	376	418	440	462	1	603	1.0	776	5.2	11	350

1. For bidirectional types having $V_{RM} \leq 10\text{V}$, I_{RM} is multiplied by 2
2. Pulse test: $t_p < 50\text{ ms}$.
3. $\Delta V_{BR} = \alpha T * (T_{amb} - 25) * V_{BR}(25^{\circ}\text{C})$.
4. $V_R = 0\text{ V}$, $F = 1\text{ MHz}$. For bidirectional types, capacitance value is divided by 2.

Figure 3. Peak power dissipation vs. initial junction temperature (printed circuit board)

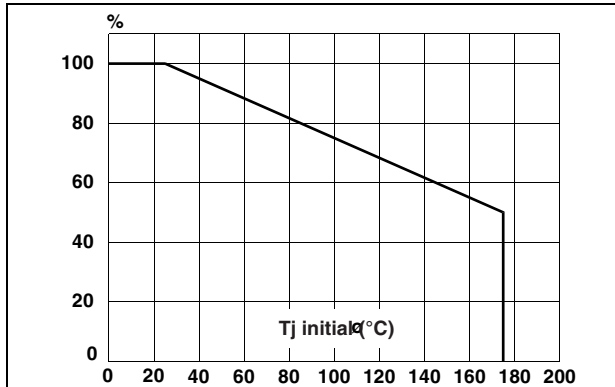

Figure 4. Peak pulse power vs. exponential pulse duration.

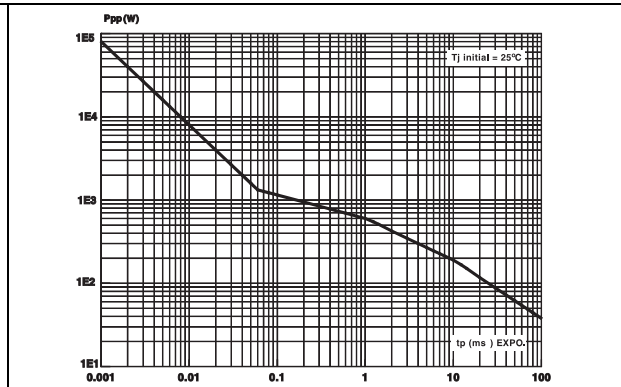

Figure 5. Clamping voltage vs. peak pulse current⁽¹⁾

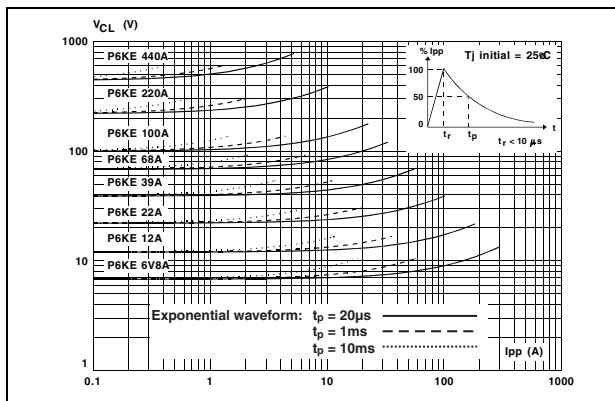
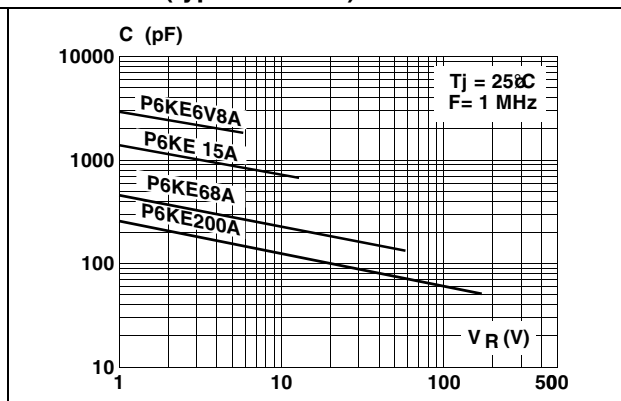

Figure 6. Capacitance vs. reverse applied voltage for unidirectional types (typical values).



1. The curves in Figure 5 are specified for a junction temperature of 25°C before surge. The given results may be extrapolated for other junction temperatures by using the following formula : $\Delta V_{BR} = \alpha T \times [T_{amb} - 25] \times V_{BR}(25^\circ C)$
For intermediate voltages, extrapolate the given results.

Figure 7. Capacitance vs. reverse applied voltage for bidirectional types (typical values).

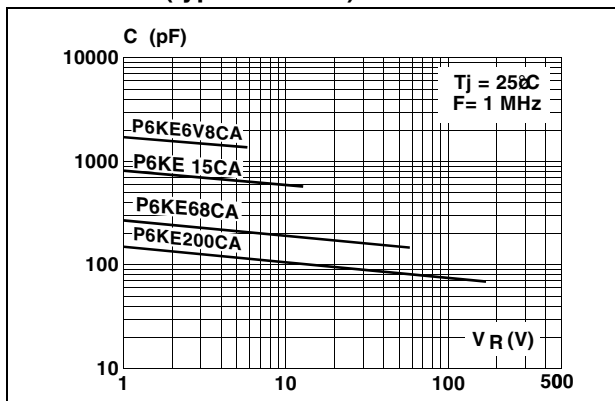
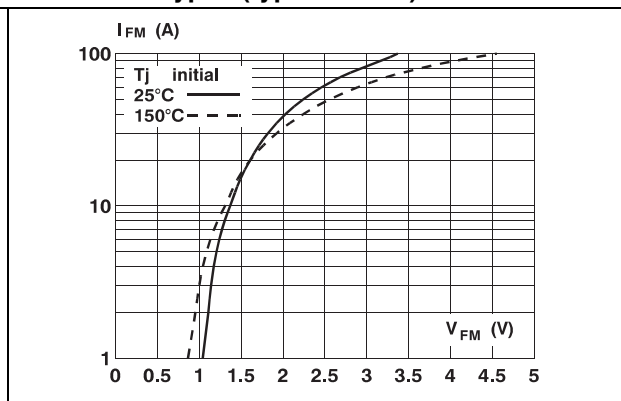

Figure 8. Peak forward voltage drop vs. peak forward current for unidirectional types (typical value).⁽¹⁾



1. Multiply by 2 for units with $V_{BR} > 220$ V.

Figure 9. Transient thermal impedance junction to ambient vs. pulse duration

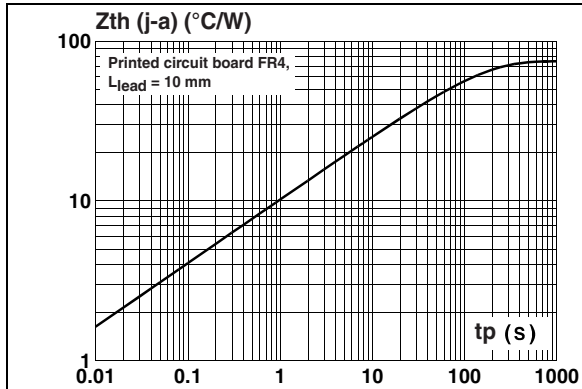
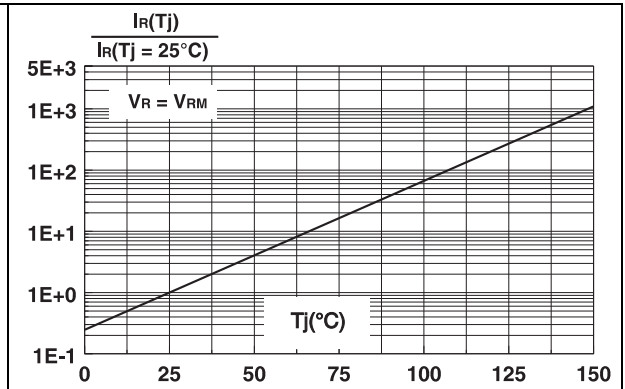
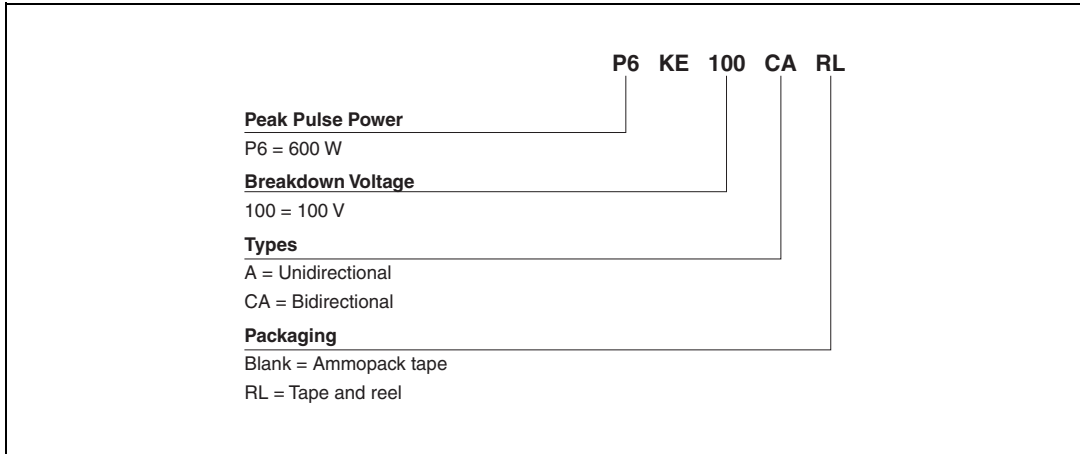

Figure 10. Relative variation of leakage current vs. junction temperature



2 Ordering information scheme

Figure 11. Ordering information scheme



3 Package information

- Epoxy meets UL94, V0
- Lead-free package

In order to meet environmental requirements, ST offers these devices in different grades of ECOPACK® packages, depending on their level of environmental compliance. ECOPACK® specifications, grade definitions and product status are available at: www.st.com. ECOPACK® is an ST trademark.

Table 4. DO-15 dimensions

Ref.	Dimensions			
	Millimeters		Inches	
	Min.	Max.	Min.	Max.
A	6.05	6.75	0.238	0.266
B	2.95	3.53	0.116	0.139
C	26	31	1.024	1.220
D	0.71	0.88	0.028	0.035

Table 5. Marking

Unidirectional order code	Marking ⁽¹⁾	Bidirectional order code	Marking ⁽¹⁾
P6KE6V8A	P6KE6V8A	P6KE6V8CA	P6KE6V8CA
P6KE7V5A	P6KE7V5A	P6KE7V5CA	P6KE7V5CA
P6KE10A	P6KE10A	P6KE10CA	P6KE10CA
P6KE12A	P6KE12A	P6KE12CA	P6KE12CA
P6KE15A	P6KE15A	P6KE15CA	P6KE15CA
P6KE18A	P6KE18A	P6KE18CA	P6KE18CA
P6KE22A	P6KE22A	P6KE22CA	P6KE22CA
P6KE24A	P6KE24A	P6KE24CA	P6KE24CA
P6KE27A	P6KE27A	P6KE27CA	P6KE27CA
P6KE30A	P6KE30A	P6KE30CA	P6KE30CA
P6KE33A	P6KE33A	P6KE33CA	P6KE33CA
P6KE36A	P6KE36A	P6KE36CA	P6KE36CA
P6KE39A	P6KE39A	P6KE39CA	P6KE39CA
P6KE47A	P6KE47A	P6KE47CA	P6KE47CA
P6KE56A	P6KE56A	P6KE56CA	P6KE56CA
P6KE68A	P6KE68A	P6KE68CA	P6KE68CA
P6KE82A	P6KE82A	P6KE82CA	P6KE82CA
P6KE100A	P6KE100A	P6KE100CA	P6KE100CA
P6KE120A	P6KE120A	P6KE120CA	P6KE120CA
P6KE150A	P6KE150A	P6KE150CA	P6KE150CA ⁽²⁾
P6KE180A	P6KE180A	P6KE180CA	P6KE180CA
P6KE200A	P6KE200A	P6KE200CA	P6KE200CA
P6KE220A	P6KE220A	P6KE220CA	P6KE220CA
P6KE250A	P6KE250A	P6KE250CA	P6KE250CA
P6KE300A	P6KE300A	P6KE300CA	P6KE300CA
P6KE350A	P6KE350A	P6KE350CA	P6KE350CA
P6KE400A	P6KE400A ⁽²⁾	P6KE400CA	P6KE400CA
P6KE440A	P6KE440A ⁽²⁾	P6KE440CA	P6KE440CA

1. Includes a space character after P6KE for ECOPACK2 compliant devices

2. Includes a space character after P6KE for ECOPACK1 compliant devices in tape and reel packaging.

4 Ordering information

Table 6. Ordering information

Order code	Marking ⁽¹⁾	Package	Weight	Base qty	Delivery mode
P6KExxxx	See Table 5	DO-15	0.4 g	1000	Ammopack
P6KExxxxRL				6000	Tape and reel

1. Logo, date code, type code, cathode band (for unidirectional types only).

5 Revision history

Table 7. Document revision history

Date	Revision	Changes
Feb-2003	4A	Last update
Oct-2004	5	1/ Note 5, figure 7 on page 4, updated from $V_{BR} > 220V$ to $V_{BR} \geq 200V$. 2/ Types table on page 2: I_{PP} (@10/1000 μ s) changed for P6KE220xx to P6KE440xx
14-Sep-2011	6	Updated I_{RM} @ V_{RM} values, V_{BRmax} @ I_R for P6KE33 and order codes in Table 3 . Updated footnotes to Table 5 . Updated T_L temperature in Table 1 .
26-Apr-2012	7	Corrected typographical area Table 3 .