

# MPC240

24" FHD TFT Medical Grade Panel Computer with 4th Generation Intel® Core™ M-series, Celeron® & Pentium® Processor

## Features

- 24" FHD TFT LCD display with LED backlight
- High performance system with 4th Generation Intel® Core™ M-series, Celeron® & Pentium® processor
- EN60601-1 and CE certified
- Spill-proof front panel design
- Supports 10-points multi-touch screen
- Antimicrobial Enclosure
- Ultra slim and Super light design
- Supports optional, wall mount, VESA mount and desktop stand

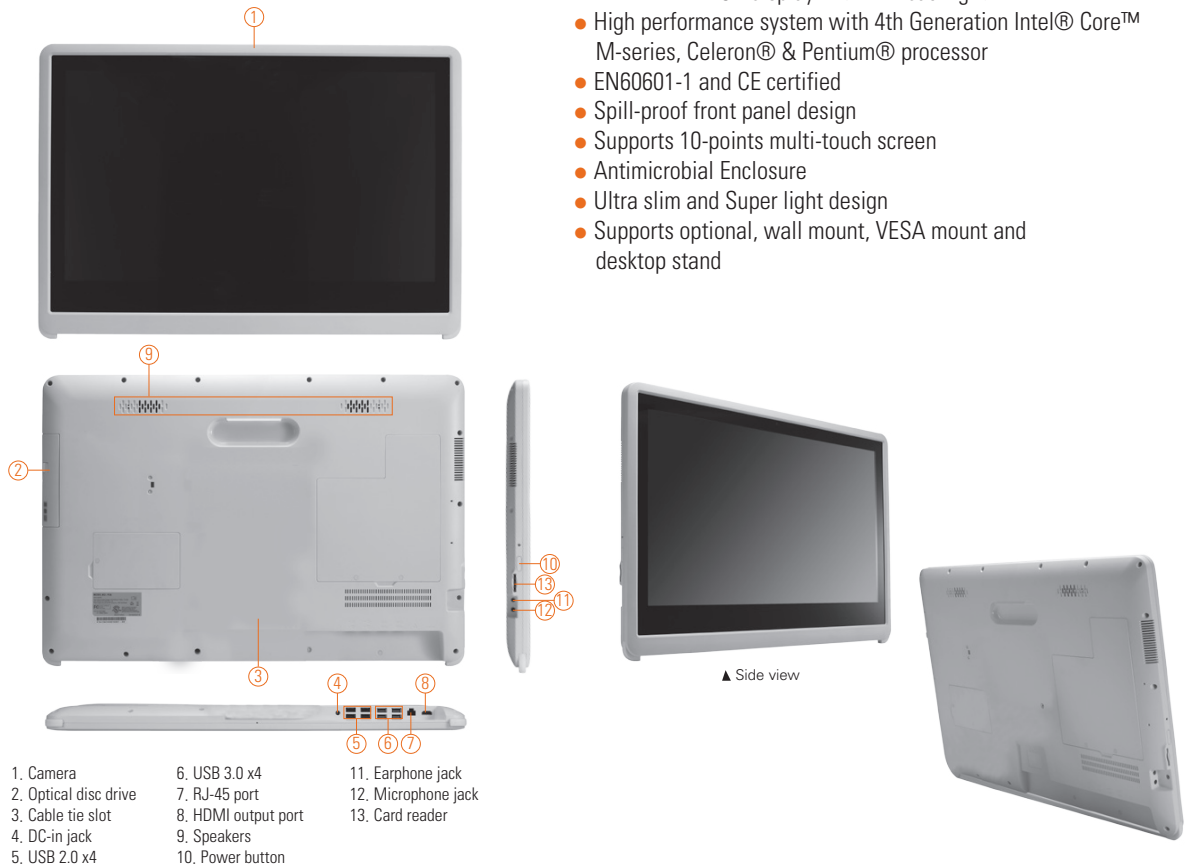

- |                       |                     |                     |
|-----------------------|---------------------|---------------------|
| 1. Camera             | 6. USB 3.0 x4       | 11. Earphone jack   |
| 2. Optical disc drive | 7. RJ-45 port       | 12. Microphone jack |
| 3. Cable tie slot     | 8. HDMI output port | 13. Card reader     |
| 4. DC-in jack         | 9. Speakers         |                     |
| 5. USB 2.0 x4         | 10. Power button    |                     |



## Introduction

The MPC240 is an Intel® Core™-based medical grade touch panel computer which is well-suited for applications like medical image processing and medical measuring instrument. Especially designed for the medical environment, it is front panel spill-proof design which protects the entire system from outside liquid, preventing system from crashing. In response to market demand, this 24" medical panel computer is a cost effective solution.

### Super slim & ultra light design

The MPC240 is a super slim 24-inch touch panel PC for space-limited environment with its thickness of 35.5 mm and weight of 6.2 kg only, which make it installed everywhere. Besides, it provides medical grade AC power adapter.

### Built-in internal WLAN

The MPC240 provides a PCIe Mini Card slot and a built-in WLAN antenna for wireless network connections. By simply plugging in the wireless LAN card, customers can use the 24-inch medical computer in a wireless LAN/GPRS/GSM/4G environments.

### Certifications

This 24" medical panel platform complies with EN60601 and CE certifications to ensure medical operation safety.

## Specifications

Front Bezel	Spill-proof	
LCD Panel	Display Type	24" FHD TFT LCD with LED backlight
	Brightness (cd/m <sup>2</sup> )	250 nits
	Resolution	1920 x 1080
Main System	CPU	4th Generation Intel® Core™ M-series, Celeron® & Pentium® processor
	System Memory	2 x 204-pin DDR3L 1600MHz sockets max. up to 16 GB, 8 GB for each socket
	BIOS	AMI BIOS
	Storage	1 x 2.5" SATA HDD 1 x M2 SATA SSD
	Watchdog Timer	255 levels, 0-255 sec.
	Onboard Graphics	Integrated in Intel® GFX

## Specifications

I/O Connector	4 x USB 3.0 4 x USB 2.0 1 x Line out 1 x Mic-in 1 x RJ-45 Jack 1 x DC-in Jack 1 x HDMI
Expansion Interface	1 x SDXC card reader slot 1 x mini card slot for Wi-Fi
Audio	2 x 1.5 KHz Speaker 1 x Microphone
Camera	1 x 2M pixels webcam
Sensor	1 x Proximity sensor
Touch screen	Projected Capacitive multi-touch 10-point
Power Supply	1. 100V-240V, 135W medical grade power adapter 2. Built-in UPS battery (optional)
Dimensions	415 mm (16.34") (W) x 35.5 mm (1.40") (D) x 610 mm (24.01") (H)
Packing Dimensions	780 mm (30.71") (W) x 160 mm (6.30") (D) x 530 mm (20.87") (H)
Weight(net/gross)	6.2 kg (13.66 lb)/9 kg (19.84lb)
Environment	Operating temperature: 5°C ~ +40°C (+13°F ~ +104°F) Storage Temperature: -30°C ~ +60°C (-22°F ~ +140°F) Relative humidity: 10%-90% @ 40°C; non-condensing
Certificate	CE, EN60601-1

## Ordering Information

MPC240	24" FHD PCT 250 nits medical grade panel computer with Intel® Core™ processor, projected capacitive touch and EN60601-1 certified
--------	---

\* Specification and certifications are based on options and may vary.

## Optional OS Installation

Windows® 7
Windows® 8.1

## Dimensions

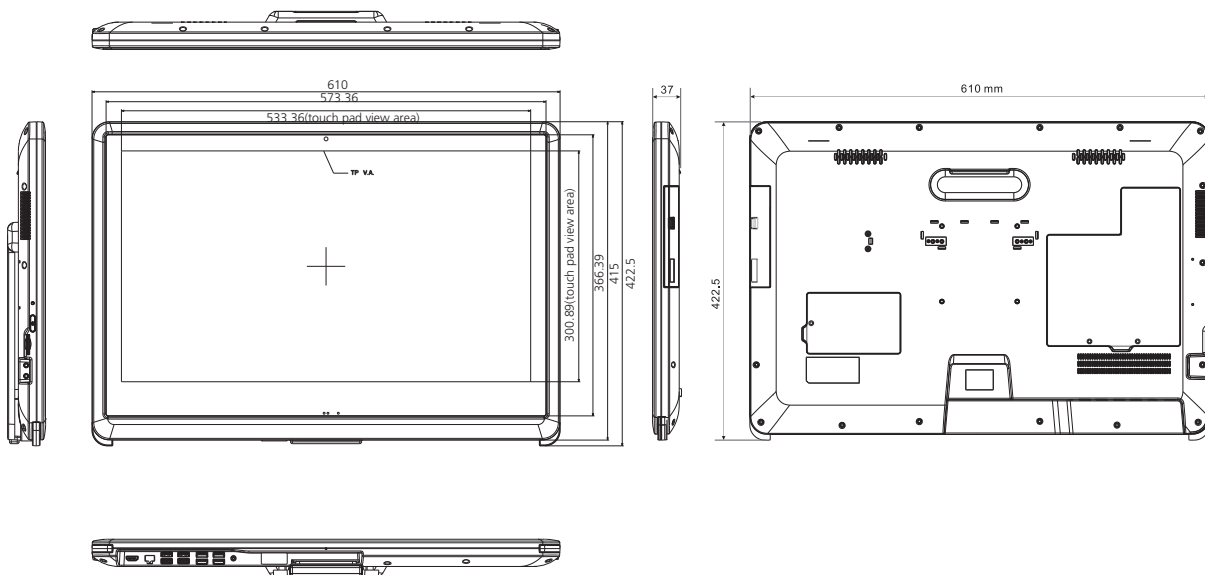

\* All specifications and photos are subject to change without notice.

axiomtek.com



© 2015 Axiomtek Co., Ltd. All rights reserved.

648