

AN3336SB

4-Head VCR Recording/Playback Amplifier IC

■ Overview

The AN3336SB is a recording/playback amplifier IC for 4-head VCR. It includes RF-AGC, automatic tracking I/O, and envelope comparing circuit.

■ Features

- Playback $V_{CC} = 5.0V$, recording $V_{CC} = 12V$
- Built-in RF-AGC circuit
- Built-in automatic tracking I/O circuit
- Built-in envelope comparing circuit

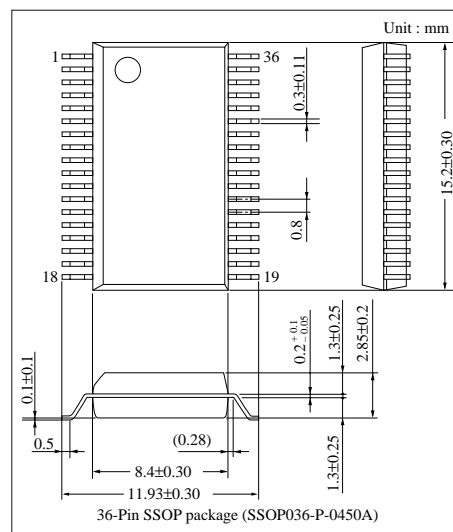

■ Pin Descriptions

Pin No.	Pin name	Pin No.	Pin name
1	Head switching	19	Envelope detector capacitor for ch 3 and ch 4
2	Envelope ON/OFF switching	20	Peaking for recording
3	Ch 1 head amp. damping	21	Automatic tracking output
4	Ch 1 head amp. input	22	Automatic tracking detector capacitor
5	Small-signal ground	23	Automatic tracking control
6	Ch 2 head amp. input	24	Automatic tracking V_{CC}
7	Ch 2 head amp. damping	25	Rec. Y-input
8	Sub-ground	26	Chroma output
9	Sub-ground	27	Sub-ground
10	Ch 3 head amp. damping	28	Sub-ground
11	Ch 3 head amp. input	29	Sub-ground
12	Small-signal ground	30	Recording C-input
13	Ch 4 head amp. input	31	AGC output
14	Ch 4 head amp. damping	32	AGC detector capacitor
15	Rec. current amp. (LP) output	33	Envelope detector capacitor for ch 1 and ch 2
16	Rec. feedback	34	Head amp. switching
17	Rec. current amp. (SP) output	35	ENV output, recording bias
18	Rec. V_{CC}	36	Playback V_{CC}

■ Block Diagram

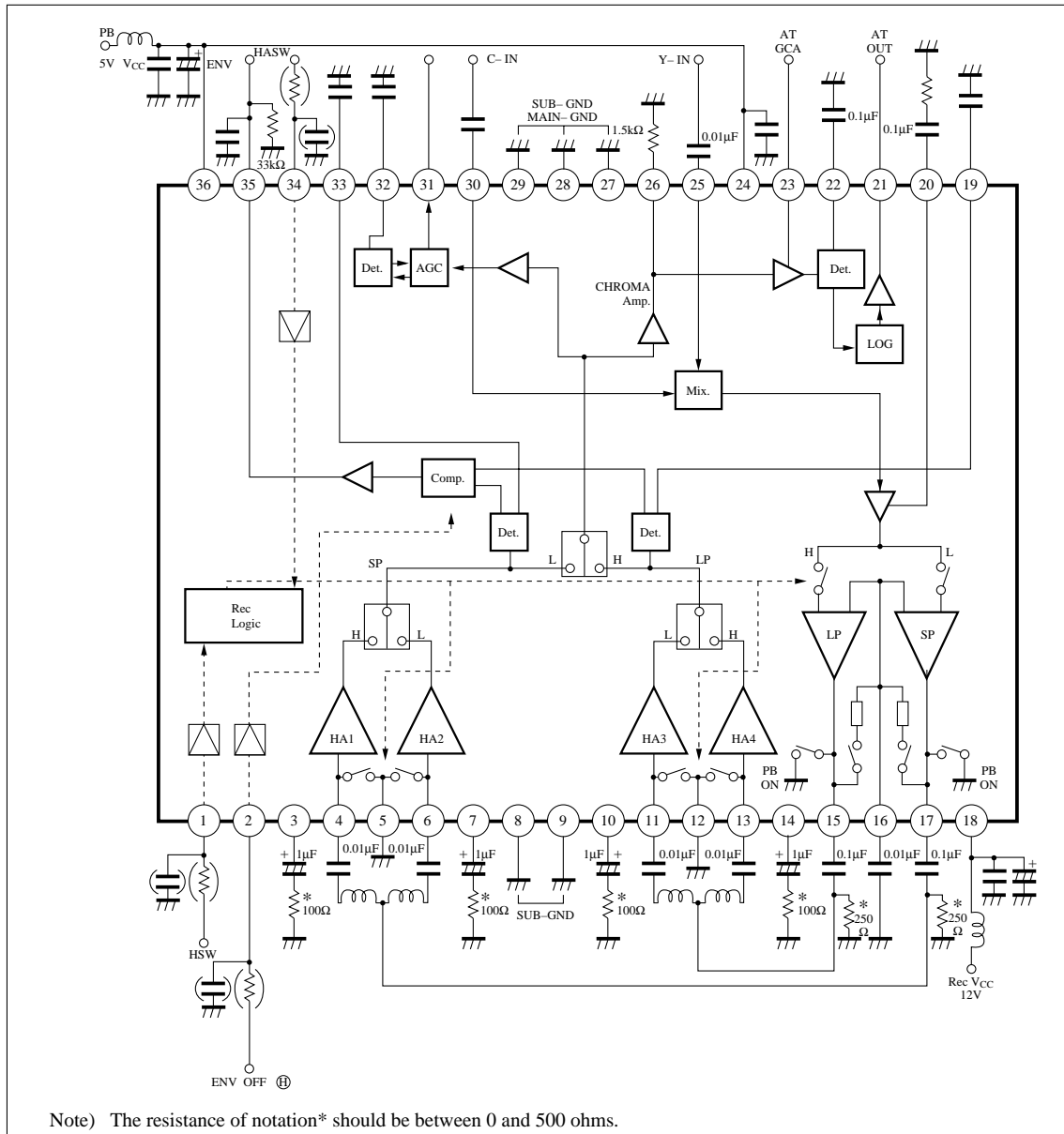

■ Absolute Maximum Ratings

Parameter	Symbol	Rating	Unit
Supply voltage (1)	PB V _{CC}	6	V
Supply current (2)	Rec V _{CC}	13	V
Power dissipation ^{Note 2)}	P _D	440	mW
Operating ambient temperature ^{Note 1)}	T _{opr}	-20 to +70	°C
Storage temperature ^{Note 1)}	T _{stg}	-55 to +125	°C

Note 1) T_a=25°C for except ambient temperature and storage temperatures.

Note 2) Allowable power dissipation of the package at T_a=70°C.

■ Recommended Operating Range (Ta=25°C)

Parameter	Symbol	Range
Operating supply voltage range (1)	PBV _{CC}	4.5V to 5.5V
Operating supply voltage range (2)	RecV _{CC}	8.5V to 12.5V

■ Electrical Characteristics (Ta=25±2°C)

Parameter	Symbol	Condition	min	typ	max	Unit
PB circuit current	I ₃₆	PB V _{CC} =5V	—	—	56	mA
CH 1 gain	G ₄₋₂₆	PB V _{CC} =5V	53	—	61	dB
CH 2 gain	G ₆₋₂₆	PB V _{CC} =5V	53	—	61	dB
CH 3 gain	G ₁₁₋₂₆	PB V _{CC} =5V	53	—	61	dB
CH 4 gain	G ₁₃₋₂₆	PB V _{CC} =5V	53	—	61	dB
HSW change-over sensitivity	S ₁	PB V _{CC} =5V	—	—	3.8	V
HASW change-over sensitivity	S ₃₄	PB V _{CC} =5V	—	—	3.8	V
AGC output amplitude	V ₄₋₃₁	PB V _{CC} =5V	130	—	270	mV _{P-P}
AGC control sensitivity	ΔV ₄₋₃₁	PB V _{CC} =5V	—	—	3.0	dB
HSW DC unbalance (I)	HSW _{26(I)}	PB V _{CC} =5V	—	—	100	mV _{P-P}
HSW DC unbalance (II)	HSW _{26(II)}	PB V _{CC} =5V	—	—	100	mV _{P-P}
HASW DC unbalance (I)	HASW _{26(I)}	PB V _{CC} =5V	—	—	100	mV _{P-P}
HASW DC unbalance (II)	HASW _{26(II)}	PB V _{CC} =5V	—	—	100	mV _{P-P}
Input conversion noise (1)	N ₄₋₂₆ /G ₄₋₂₆	PB V _{CC} =5V	—	—	1.0	μVrms
Input conversion noise (2)	N ₆₋₂₆ /G ₆₋₂₆	PB V _{CC} =5V	—	—	1.0	μVrms
Input conversion noise (3)	N ₁₁₋₂₆ /G ₁₁₋₂₆	PB V _{CC} =5V	—	—	1.0	μVrms
Input conversion noise (4)	N ₁₃₋₂₆ /G ₁₃₋₂₆	PB V _{CC} =5V	—	—	1.0	μVrms
Auto-tracking output at no-input	V _{21min.}	PB V _{CC} =4.8V	—	—	1.0	V
Auto tracking max. output	V _{21max.}	PB V _{CC} =4.8V	3.8	—	—	V
ENV output amplitude	V ₃₅	PB V _{CC} =5V	3.5	—	—	V _{P-P}
Rec. circuit current	I ₁₈	Rec V _{CC} =12V	—	—	48	mA
SP Y-Rec. current output	I ₁₇	Rec V _{CC} =12V	17	—	32	mA _{P-P}
LP Y-Rec. current output ratio	I ₁₅ /I ₁₇	Rec V _{CC} =12V	-2.5	—	2.5	dB
SP 8MHz f characteristics ratio	I _{17H} /I ₁₇	Rec V _{CC} =12V	-4	—	—	dB
LP 8MHz f characteristics ratio	I _{15H} /I ₁₅	Rec V _{CC} =12V	-4	—	—	dB
Rec. chroma output ratio	I _{17C} /I ₁₇	Rec V _{CC} =12V	-15	—	-7	dB
PB circuit current	I ₃₆	PB V _{CC} =5V	—	(43)	—	mA
CH 1 gain	G ₄₋₂₆	PB V _{CC} =5V	—	(57)	—	dB
CH 2 gain	G ₆₋₂₆	PB V _{CC} =5V	—	(57)	—	dB
CH 3 gain	G ₁₁₋₂₆	PB V _{CC} =5V	—	(57)	—	dB
CH 4 gain	G ₁₃₋₂₆	PB V _{CC} =5V	—	(57)	—	dB
AGC output amplitude	V ₄₋₃₁	PB V _{CC} =5V	—	(200)	—	mV _{P-P}
Rec circuit current	I ₁₈	Rec V _{CC} =12V	—	(33)	—	mA
SP Y-Rec. current output	I ₁₇	Rec V _{CC} =12V	—	(12)	—	mA _{P-P}
Rec. chroma output ratio	I _{17C} /I ₁₇	Rec V _{CC} =12V	—	(-12)	—	dB
Rec. current 2nd harmonics distortion	D _{2f}	Rec V _{CC} =12V	—	(-43)	—	dB
Cross-modulation relative level	D _M	Rec V _{CC} =12V	—	(-48)	—	dB
Auto tracking SP output voltage (1)	V _{21SP1}	PB V _{CC} =4.8V, V _{in} =400mV _{P-P}	(3.4)	—	(3.9)	V
Auto tracking SP output voltage (2)	V _{21SP2}	PB V _{CC} =4.8V, V _{in} =100mV _{P-P}	(1.5)	—	(2.5)	V
Auto tracking LP output voltage difference	V _{21LP} -V _{21SP2}	PB V _{CC} =4.8V	(0.1)	—	(0.5)	V

Note) The characteristics value in parentheses is not a guaranteed value, but reference one on design.

■ Functional Descriptions

1. Playback mode

- Pin36 (playback V_{CC}) = 5V typ. (Pins15 and 17 are grounded internally)
- Pin18 (recording V_{CC}) = open

(1) Selecting a head amplifier output channel

	Channel	Input pin	Head SW Pin1	HASW Pin34
SP	1	4	H	L
	2	6	L	L
LP	3	11	L	H
	4	13	H	H

(2) Starting the envelope comparator

Env. ON/OFF SW Pin2	Open	Low (special playback)
Env. comparator	Inactive	Active

(3) Automatic tracking interface

Pin24 (automatic tracking V_{CC}) = 5V typ.

HASW(Pin24)	Automatic tracking
High	LP
Low	SP

- When the SP mode of the automatic tracking interface switches to the LP mode, the gain of the amplifier increases 5.5dB.
- When the gain control voltage at Pin23 increases, the gain of the circuit increases.

2. Recording mode

Pin18 (recording V_{CC}) = 12V typ.

Pin36 (playback V_{CC})
Pin24 (automatic tracking V_{CC}) } Opened or grounded

Pin35 : Recording internal bias current control

How to control :

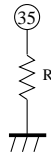

- When the external resistance decreases, the internal circuit bias current (I_{total}) increases.
- R should be 27 to 33k Ω .

○ HASW control at Pin34

HASW Pin34	SP output	LP output	Pin11,13	Pin4,6	Pin19
H	OFF	active	GND	Diode	Open
L	active	OFF	Diode	GND	GND

■ Reference

