

Стеллаж АСТИ / Rack ASTI

Код ТН ВЭД ЕАЭС

9403 60 100 1

9403 90 300 0



отрезать
и приклеить

Паспорт изделия

| | | |
|-----|------|-----|
| | | |
| 800 | 1822 | 296 |

АСББ / 4358



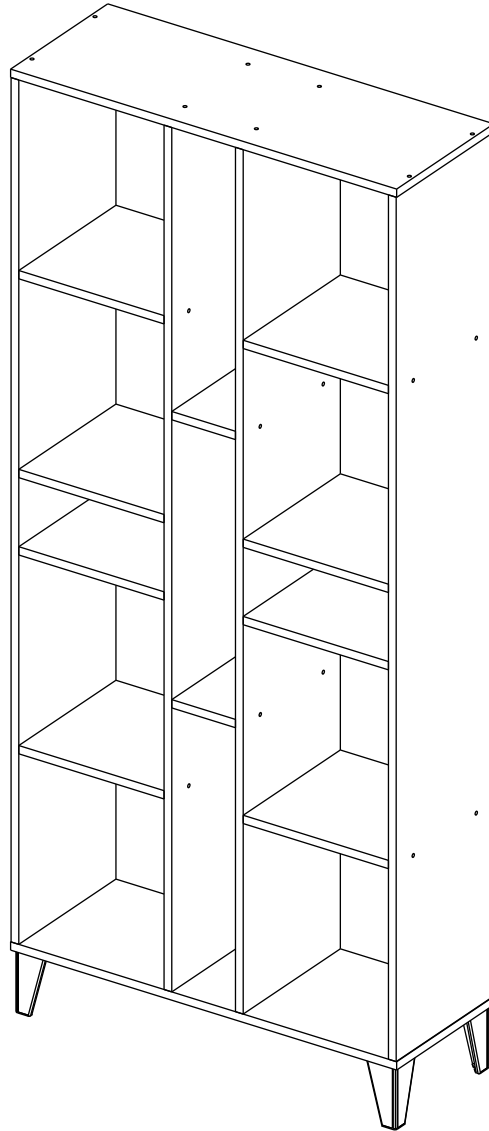

АСБЗ / 4348

АСБС / 4359

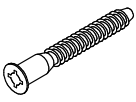
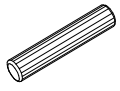

Комплектовочная ведомость / Set package sheet

| Упак/ Package | Наименование | Description | Цвет детали/ Décor | | | Размер / Size, mm | Кол-во/ Quantity | № |
|------------------|------------------|-----------------------------------|----------------------|------------------|--------------------|----------------------|---------------------|---|
| | | | White- Craft gold | White- Sonoma | White- Concrete | | | |
| 1 | Фурнитура | Furniture/Cabinetry hardware | - | - | - | - | 1 | - |
| 2 | Боковина | Side | White | White | White | 1665x296 | 2 | 1 |
| | Крыша | Top | White | White | White | 800x296 | 2 | 3 |
| | Вязка | Connecting element | Craft gold | Sonoma | Concrete | 301x296 | 4 | 4 |
| | Вязка | Connecting element | Craft gold | Sonoma | Concrete | 132x296 | 1 | 5 |
| | Вязка (шкант) | Connecting element (Wooden Dowel) | Craft gold | Sonoma | Concrete | 301x296 | 4 | 6 |
| | Вязка | Connecting element | Craft gold | Sonoma | Concrete | 132x296 | 1 | 5 |
| | Боковина средняя | Side middle | Craft gold | Sonoma | Concrete | 1665x296 | 2 | 2 |

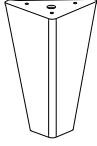
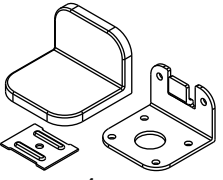
| | | | | | | | | | |
|---|-------------|---|--------------|---|------|---|--|---|--------|
| 3 | | 5 | 7x50 | 7 | 8x30 | 15 | | 18 | 3,5x15 |
|  | |  | |  | |  | |  | |
| 1 x | | 40 x | | 16 x | | 1 x | | 18 x | |
| 72 | alder/white | 135 | X039 H125 mm | 69 | | | | | |
|  | |  | |  | | | | | |
| 16/16 x | | 4 x | | 1 x | | | | | |

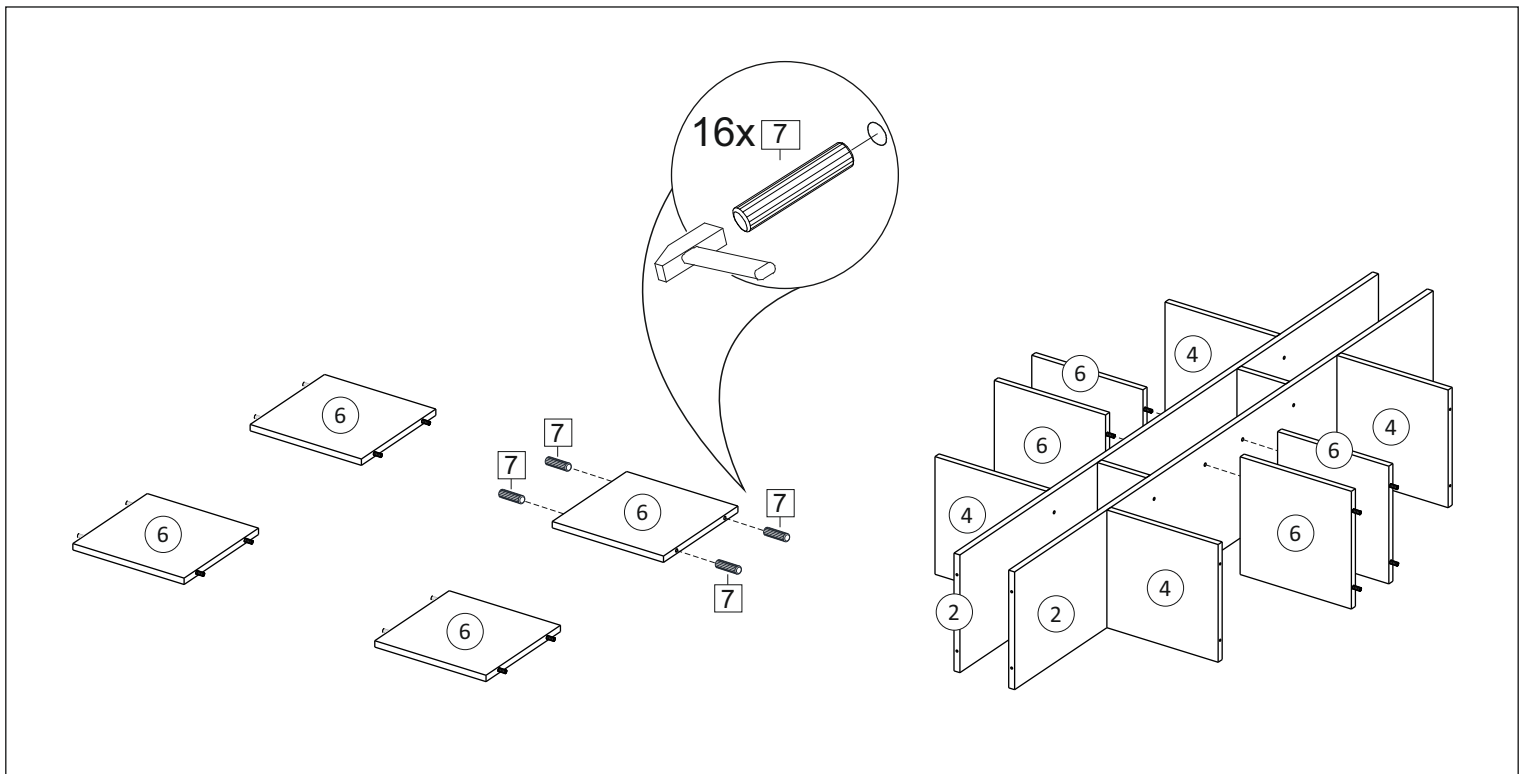
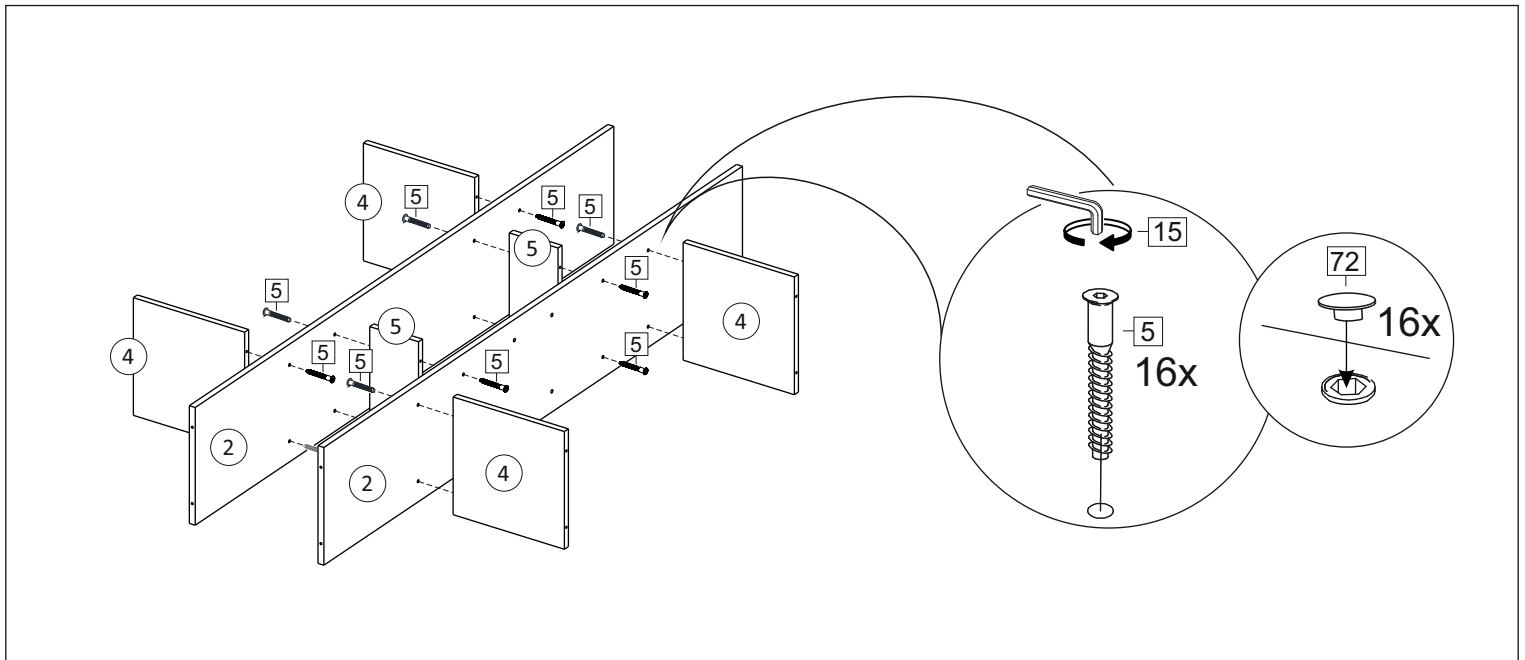

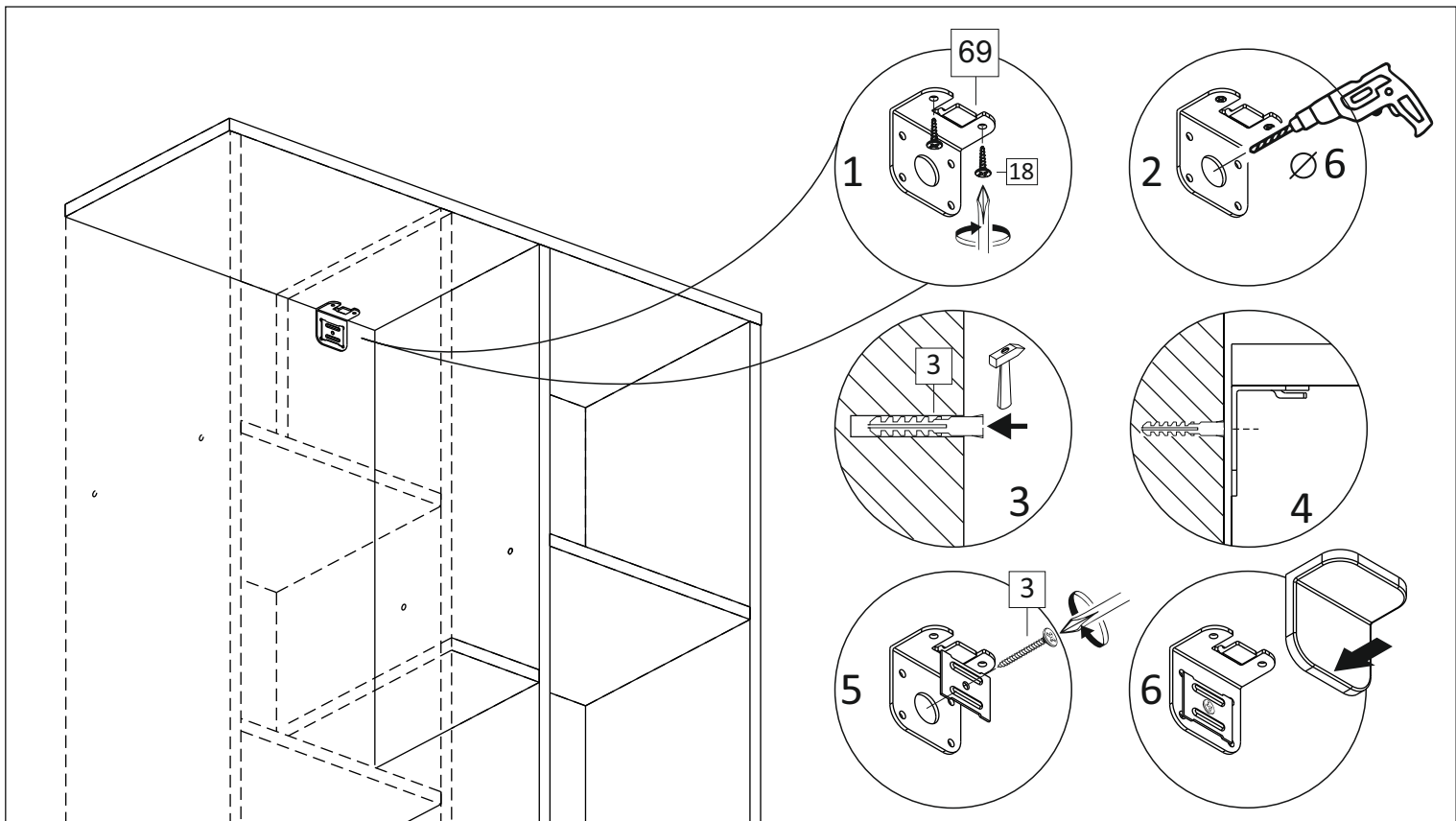
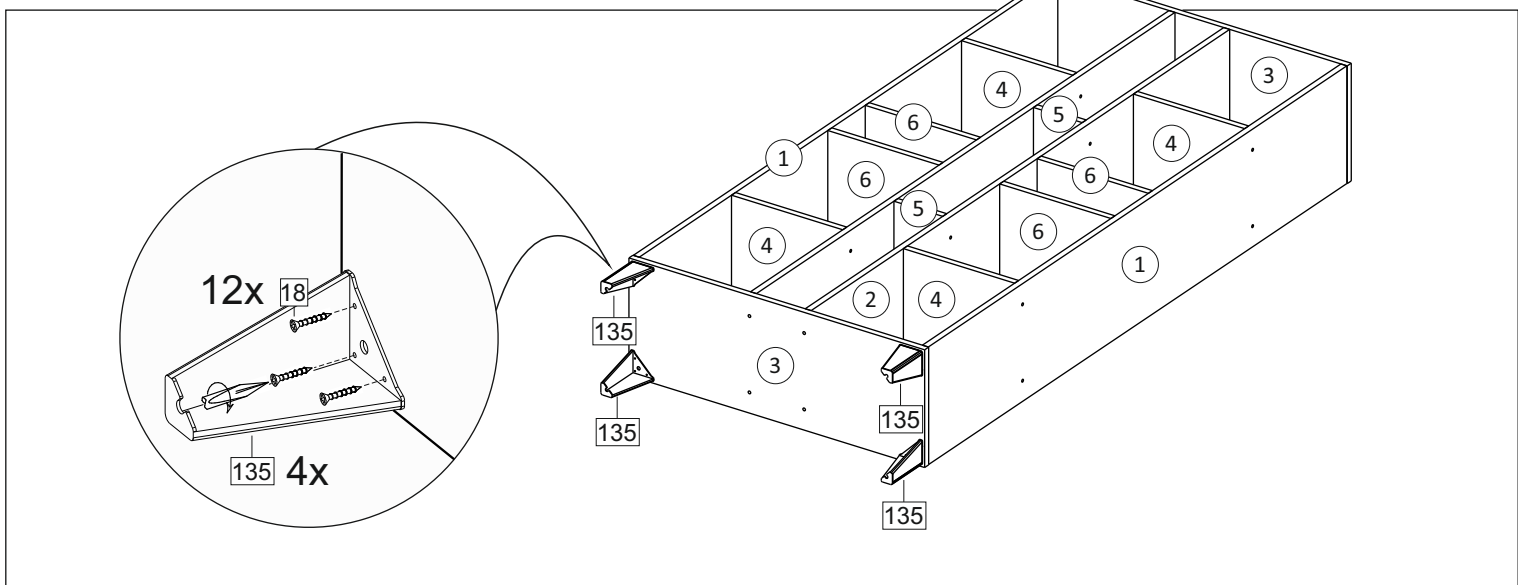
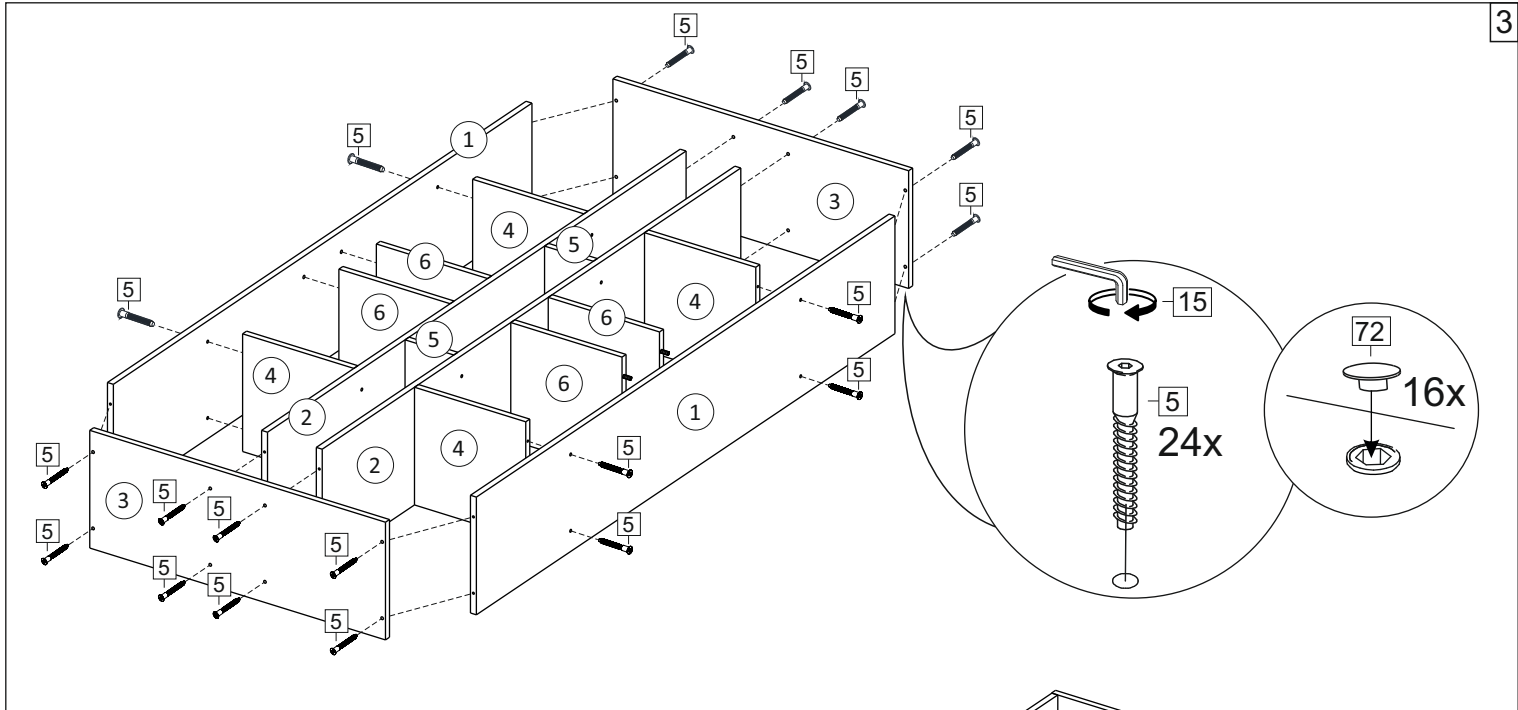

(PL) Instrukcja montażu

(CZ) Návod k montáži

(D) Montageanleitung

(GB) Assembly instruction

(F) Model d'emploi

(HU) Szerelési útmutató

(I) Istruzione di montaggio

(NL) Handleiding voor de montage



(RU) Инструкция по монтажу

(RO) Instrucțiuni de montare

(SK) Návod k montáži

(TR) Montaj talimatı

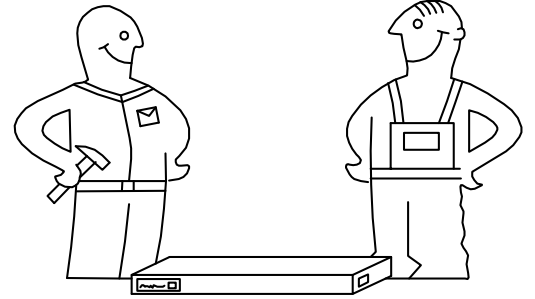
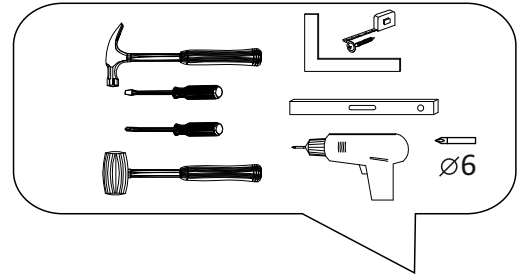

| ⚠ Uwaga • Upozornění • Achtung • Attention • Caution • Figyelem ⚠ | |
|--|--|
| ⚠ Attentione • Opgelet • Внимание • Atenție • Upozornenie • Dikkat ⚠ | |
| PL | Czyszczenie należy wykonać wyłącznie za pomocą ściereczki lub lekko nawilżonego ręcznika. Nie stosować środków czyszczących do szorowania. |
| CZ | Čistění je nutné vykonávat výhradně pomocí utěrky nebo lehce navlhčeného ručníku. Nepoužívejte čističí prostředky obsahující abrazivní částice. |
| D | Bitte nur mit einem Staubtuch oder leicht feuchtem Lappen reinigen. Keine scheuernden Putzmittel verwenden. |
| GB | Please only clean with a duster or a damp cloth. Do not use any abrasive cleaners. |
| F | Le nettoyage se fait uniquement à l'aide d'un torchon ou d'une serviette légèrement mouillée. |
| HU | A tisztítás kizárólag törölőruha vagy enyhén nedvesített törölköző segítségével végezhető. Súroló hatású tisztítószereket nem szabad használni. |
| I | Pulire esclusivamente con un panno o un asciugamano umido. |
| NL | Reinig alleen met een stofdoek of een lichtjes vochtige doek. Gebruik geen schurende poetsmiddelen. |
| RU | Очищайте от пыли тряпкой или слегка влажной ветошью. Не допускается применение чистящих средств, не предназначенных для ухода за мебелью. |
| RO | Curățarea trebuie efectuată numai cu o cârpă sau cu un prosop ușor umezit. Nu utilizați agenți de curățare abrazivi. |
| SK | Čistení je nutné vykonávať výhradne pomocí utierky alebo ľahko zvlhnutým ručníkom. Nepoužívajte čistiace prostriedky obsahujúce abrazívne častice. |
| TR | Lütfen sadece bir toz bezilye veya hafif nemli yumuşak bir bezle siliniz. Aşındırıcı temizlik malzemeleri kullanmayınız. |

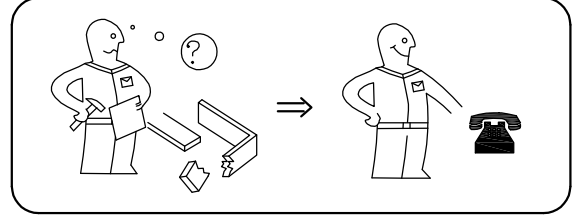
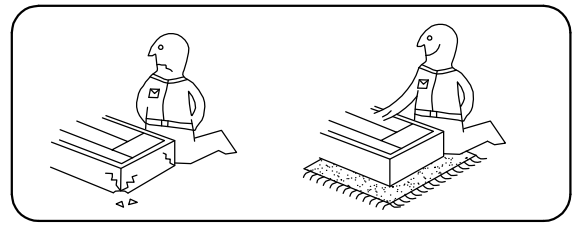

**Karta serwisowa • Servisní list • Service Karte • Service card • Carte de service • Szervizkártya
Scheda di servizio • Service kaart • Сервисная карта • Fisa service • Servisný list • Servis karti**

