

# Transistors

## BC308

### SWITCHING AND AMPLIFIER APPLICATIONS

• LOW NOISE

#### ABSOLUTE MAXIMUM RATINGS ( $T_a = 25^\circ\text{C}$ )

Characteristic	Symbol	Rating	Unit
Collector-Emitter Voltage	$V_{CES}$	-30	V
Collector-Emitter Voltage	$V_{CEO}$	-25	V
Emitter-Base Voltage	$V_{EBO}$	-5	V
Collector Current (DC)	$I_C$	-100	mA
Collector Dissipation	$P_C$	500	mW
Junction Temperature	$T_J$	150	$^\circ\text{C}$
Storage Temperature	$T_{stg}$	-55~150	$^\circ\text{C}$

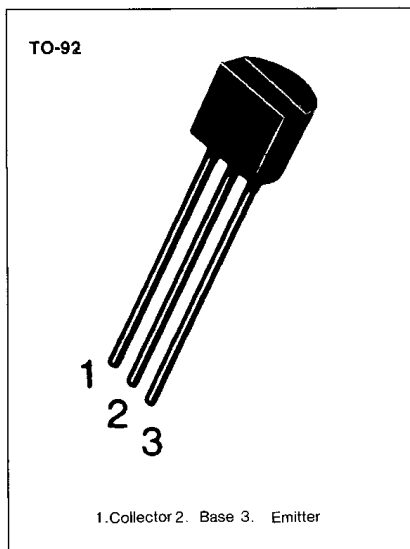

#### ELECTRICAL CHARACTERISTICS ( $T_a = 25^\circ\text{C}$ )

Characteristic	Symbol	Test Condition	Min	Typ	Max	Unit
Collector Emitter Breakdown Voltage	$BV_{CEO}$	$I_C = -2\text{mA}, I_B = 0$	-25			V
Collector Emitter Breakdown Voltage	$BV_{CES}$	$I_C = -10\mu\text{A}, I_B = 0$	-30			V
Emitter Base Breakdown Voltage	$BV_{EBO}$	$I_E = -10\mu\text{A}, I_C = 0$	-5			V
Collector Cutoff Current	$I_{CES}$	$V_{CE} = -45\text{V}, I_B = 0$ $V_{CE} = -25\text{V}, I_B = 0$		-2	-15	nA
DC Current Gain	$h_{FE}$	$V_{CE} = -5\text{V}, I_C = -2\text{mA}$	120		800	
Collector Emitter Saturation Voltage	$V_{CE(sat)}$	$I_C = -10\text{mA}, I_B = -0.5\text{mA}$ $I_C = -100\text{mA}, I_B = -5\text{mA}$		-0.5	-0.3	V
Collector Base Saturation Voltage	$V_{BE(sat)}$	$I_C = -10\text{mA}, I_B = -0.5\text{mA}$ $I_C = -100\text{mA}, I_B = -5\text{mA}$		-0.7	-0.85	V
Base Emitter On Voltage	$V_{BE(on)}$	$V_{CE} = -5\text{V}, I_C = -2\text{mA}$	-0.55	-0.62	-0.7	V
Current Gain Bandwidth Product	$f_T$	$V_{CE} = -5\text{V}, I_C = -10\text{mA}, f = 50\text{MHz}$		130		MHz
Collector Base Capacitance	$C_{CBO}$	$V_{CB} = -10\text{V}, f = 1\text{MHz}$			6	pF
Emitter Base Capacitance	$C_{EBO}$	$V_{EB} = -0.5\text{V}, f = 1\text{MHz}$		12		pF
Noise Figure	NF	$V_{CE} = -5\text{V}, I_C = -0.2\text{mA}$			10	dB

#### $h_{FE}$ CLASSIFICATION

Classification	A	B	C
$h_{FE}$	120-220	180-460	380-800

