

Content

- I 、 Generality**
- II 、 Principle of Operation**
- III、 Product Feature**
- IV、 Basic Parameter / Technical Specification**
- V、 Product Category**
- VI、 Types Choice**
- VII、 Installation Size**
- VIII、 Caution in Installation**
- IX、 Connection**
- X、 Adjustment and Application**
- XI、 Caution in Using**
- XII、 Problem & Solution**
- XIII、 Transportation & Storage**
- XIV、 Cautions in Unpacking**
- X V、 Necessary Knowledge on Order**

I 、 Generality

Turbine Flow Meter (Abbr. TUF) is a main type of Impeller Flowmeters also including the Anemoscope and Water meter. TUF is made up of Sensor and Conversion-Show. The Sensor reacts to the average velocity of fluid with multi-blades rotor so as to speculating the flow value and the accumulative flow value. The velocity (or circles) of rotor can be picked up by the way of mechanism, electromagnetic induction, photoelectricity, before displaying and transmitting the records by reading device.

It is said that America announced the first TUF patent early in 1886. The patent in 1914 recorded that the TUF flow value is relevant to frequency. The first developed TUF in 1938 is applied to measuring the fuel flow in the aircraft. It is eventually achieved to use in the industry until the end of the world war two, since it is urgent for the jet engine and liquid jet fuel to demand high accuracy, quick responses flow measurement instrument. Nowadays, it can be extensively used in the fields of oil,chemical,defence,science,measuring, etc..

LWGY series Turbine Flowmeters draw the leading technology integrating with advanced design to produce the new generation of turbine flowmeter with the features of simple structure, light weight, high accuracy, good repeatability, flexible reaction, convenient installation/maintenance/application etc.. It is widely applied to measuring the liquid of which kinematic viscosity is under $5 \times 10^{-6} \text{ m}^2/\text{s}$ and have no impurity of fibre,grain etc.,and no corrosive interaction with the stainless steel

1Cr18Ni9Ti, 2Cr13, and Al₂O₃, and hard alloy in seal pipes. The liquid of kinematic above $5 \times 10^{-6} \text{ m}^2/\text{s}$ can be measured after real liquid calibration of flowmeter. It can be used in value control, siren when excess, if co-ordination with special display instrument. So it is the ideal instrument of measuring flow value and saving energy.

II、 Principle of Operation

As the measured liquid flows through the sensor, the driven vane begins to turn, which velocity is in direct proportion to average flow one in the pipe. The turn of vane periodically changes the magnetic resistance value of magnetoelastic transducer. Magnetic flux in the magnetic test coil happens to change cyclically with it to produce periodic induced voltage, it is the pulse signal, that will be sent to the display to show after amplified by magnifier.

Flow rate equation of Turbine Flowmeter includes both practical and theoretical one:

(1) Practical equation:

$$Q_v = f / k$$

$$Q_m = Q_v \cdot \rho$$

Q_v refers to volume flow rate, (unit: m^3/s)

Q_m refers to mass flow rate, (unit kg/s)

f : refer to output signal frequency (unit Hz)

k : refer to the Flowmeter factor, (unit P/m^3).

The related curve of flowmeter factor and flow rate is in the graph (Diagram: Turbine flowmeter characteristic curve). As you see, the factor curve can be divided into two parts of

linearity and non-linearity. The linear part accounts for two-thirds of the entire curve which feature is related to the structure, size of sensors, and fluid viscosity. The feature in non-linearity part is influenced by friction force from bearing, the viscosity resistance of liquid. When flow rate is below the lower limit of sensor, the instrument factor are quickly increasing with it. The value of pressure loss and the flow rate are similar to be square relations. If flow rate surpassed the upper limit, pay attention to preventing from cavitation. When the turbine flowmeters have similar structure, their curves have similar feature but have different system errors.

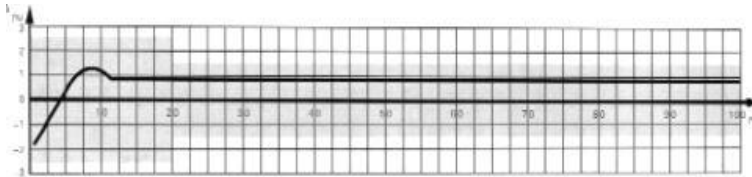

(Diagram: Turbine flowmeter characteristic curve)

The sensor factor can be worked out by calibration instrument, which may have no consideration of the sensor's inside fluid mechanism, and can be confirmed by inputed flow rate and outputed pulse signals of

frequency. So we can see the sensor as a black box , that is convenient for application. But please note that the conversion factor (or instrument factor) should comply with some conditions which calibration condition is the reference condition . If it deviate from this condition, the factor will happen to change. The changes would be determined in terms of the sensors type, the

pipe installation condition, and fluid physical parameters.

(2) Theoretical flow rate equation:

According to the moment of momentum theorem, we can list the equation of motion for the impeller.

$$J \frac{d\omega}{dt} = M_1 - M_2 - M_3 - M_4$$

In the formula,

J: impeller inertia moment;

$\frac{d\omega}{dt}$: rotational acceleration;

M_1 : Liquid-driven torque

M_2 : Viscous resistance moment

M_3 : Bearing friction moment

M_4 : Magnetic moment.

When the impeller is rotating at a constant velocity, $J \frac{d\omega}{dt} = 0$, and $M_1 = M_2 + M_3 + M_4$. Through the analysis in theory and verification in experiment, the formula can be deduced that is:

$$n = Aq_v + B - C q_v$$

In the formula,

n: refers to impeller rotational speed;

q_v : refers to volume flow rate;

A: the factors related to fluid physical properties (include density, viscosity etc.), impeller structure parameters (blade angle, impeller diameter, flow channel cross-sectional area etc.);

B: the factors related to top vane gap, and fluid flow velocity distribution;

C: the factor related to friction moment.

The scholars domestic and abroad have put forward many flow

equations in theory, applied to various sensors structures and fluid working conditions. Until now, the hydrodynamic characteristic of turbine instrument ones is still unclear, for it has complicated relationship with fluid physical property, and flow characteristics. For instance, when there appears to swirling and unsymmetry velocity distribution in flow field, the hydrodynamic characteristics are very complicated.

So instrument factors can not be deduced by theoretical formula, can be confirmed by real flow calibration. But theoretical formula has been significant in practice. It can be used in instruction in the design of sensor structure parameter and the forecast ,and assessment of instrument factor changing rule.

III、 Product Feature:

- (1) High accuracy (regular accuracy $\pm 1\%R$, $\pm 0.5\%R$, highest accuracy $\pm 0.2\% R$);
- (2) Good repeatability (short-term one reaches 0.05%--0.2%), priority to be used in trade settlement for its extremely high accuracy in the regular calibration or on-line calibration.
- (3) Pulse frequency signal output is applicable to totality calculation and computer connection with no zero drift and strong anti-interference capacity.
- (4) High frequency (3-4kHz) can be achieved, and has high resolution.
- (5) Wide rangeability: medium or large diameter may reach 1:20,and small diameters are 1:10.

- (6) Compact and light weight structure, convenient installation and maintenance, extensive application ability.
- (7) Application to high pressure measurement with its unnecessary opening hole to be made into high pressure instruments.
- (8) Complete tailored version sensors can be designed to different kinds of types according to users special needs. For instance, low temperature type, high pressure type, sanitary type, etc.
- (9) Insertion type can be made, that is applicable to large normal diameters measurement for its little pressure loss, low price, unnecessary stopping flow to take out it, and convenient installation and maintenance.

—, The main technical parameters

1. Applicable Diameter: DN15-DN300, other caliber supply agreement. Applicable medium: gas, vapor, liquid.

2. Environmental conditions: Ambient temperature: (- 30 ~ + 70) °C / (- 20 ~ + 70 °C liquid crystal display).

Relative humidity: 5% to 90% Atmospheric pressure: (86 ~ 106) kPa.

Medium temperature: (- 50 ~ + 100) °C, (- 50 ~ + 200) °C.

3. Power supply:

a) TB3WE three-wire:

(1) with external power supply: 12 ~ 24VDC / 30mA (-20% ~ + 15%), weak output as low as 6V.

(2) battery power (optional): Lithium battery 3.6V (2-13Ah) /0.4mA.

b) TB2WE wire system: 12 ~ 24VDC / 4-20mA (-20% ~ +15%).

4. output signal

a) TB3WE three-wire:

(1) pulse output: high $\geq 8V$ (supply voltage -1V). LOW $<0.5V$.

Open (2) including pull-up resistor 2K7 collector output.

(3) RS485 communication: the instrument can be configured to RS485 communication interface. Communication distance $\leq 1200\text{mm}$.

b) TB2WE wire system:

(1) two-wire 4 ~ 20mA linear calibration current output (24V when the load circuit $\leq 600\Omega$).

(2) only of calibration (interference current) without correction original pulse output: high $\geq 5V$ (supply voltage -1V).

(3) low $<0.5V$; containing 2K7 pull-up resistor on the open collector output. When the effective power loss prospective.

Second, the basic outline

TB3W / 2WE three-wire / two-wire E Series display circuit is a new thin-circuit turbine flowmeter, the amplifier circuit is analog. Accurate flow measurement of gases and liquids in the conventional flow range. It can be

adapted to all kinds of various calibres and measuring medium. After the data processing and signal remote circuit is divided into three-wire and two-wire system. Three-wire RS485 communication can bring, and battery-powered. With two-wire 4-20mA current output can be connected only with a calibrated (with the current conflict) of the original pulse output.

According to customer order requirements, flow turbine flow transmitter output zero and full scale values in the factory before the commissioning good. After the meter is running, if the site needs to zero the flowmeter output is adjusted according to the following methods:

Close the flow meter pipe valve, make sure there is no flow in the pipeline, connect the power meter, ammeter in series (multimeter DC current file), to monitor the flow meter output current; trimming potentiometer W502 converter circuit board, so that the output Back to current 4mA.

After running the meter, the meter full-scale output value in the field can not be re-adjusted for the adjustment, set the meter Depot completed by the manufacturer according to your requirements in the standard flow apparatus.

Basic parameters

Supply voltage: 24V

Output signal: 4-20mA / 1-10V / 1-5V

2. Electrical connections and adjustment

Transmitter Wiring: red --24V +
Black (green) line --0V

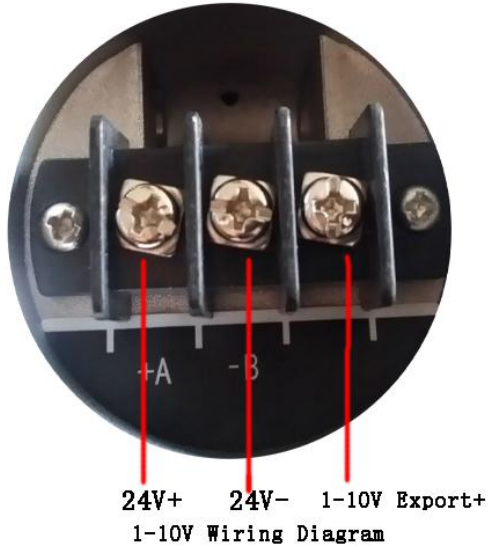

Third, the instrument wiring

Instrument wiring in the enlarged board, large terminal is the main terminals must be used, small terminal for the auxiliary terminal functions additional wiring.

(A) TB3WE three-wire circuit wiring

The main power supply and signal output terminals (spinning frame hanging on the left three terminals)

Fout (i) (x)

Fout: pulse output. (I): for the power "-" or current outflow

end. (X): External 12V ~ 24VDC power supply + terminal.

(X) and (i) When connected to the external power supply circuit (battery-powered electric work is transferred to state), pulse output leads from Fout.

Auxiliary terminal (small terminal) 3-pin jumper between the main terminals and auxiliary terminals for pulse output switch, inserted in the outer FO pulse output, inserted in the inside of the NC is disconnected so that no pulse output. Two-wire type plug for current tests only when the outside with the inside of the current must be plugged off pulse output, or will the current allowed.

+ 3V6 3V6- B- A +

1) Battery Cable :(small terminal in the right position 1,2)
+ 3V6: 3.6V lithium battery connected to the "+" side.
3V6-: 3.6V lithium battery connected "-" end

2) Communications Wiring :(small terminal in the left position 3,4) No 485 models do not deserve this Terminal

B-: The RS485 communication "B-" end. A +: The RS485 communication "A +" terminal

(B) TB2WE two-wire circuit wiring

1, the main power supply and signal output terminals (on the left two hanging frame spinning terminals)

Fout (i) (x)

(I): For 4 ~ 20mA current output. (X): For 15 ~ 24V power supply and "+"

(X) connected to + 24V external power supply, the

current output from the outflow end (i) to the computer or display sampling resistor table, through sampling resistor. Once the load flow back into power "-" terminal.

Auxiliary terminal (three small terminal)

4 ~ 20mA current output type without auxiliary small terminal

Fout: pulse output. (X) and (i) When connected to the external power supply circuit, pulse output leads from Fout. 3-pin jumper next to the main terminal for the pulse output switch, connected to the outside FO pulse output, inserted in the inside of the disconnect so that no pulse output. Two-wire type plug for current tests only when the outside with a current must be inserted in the inside of the NC off pulse output, or will the current allowed. This pulse output without correction of the original pulse, usually used only during calibration; output signal containing 2K7 pull-up resistor on the open collector output.

System wiring diagram can be found in the drawings "TB3WE TB2WE three-wire and two-wire circuit wiring diagram"

Three-wire Pulse output Turbine flowmeter Wiring:

Yellow Line: Pulse output

Red Line: 24V+ power supply

Green Line: 24V -- power supply

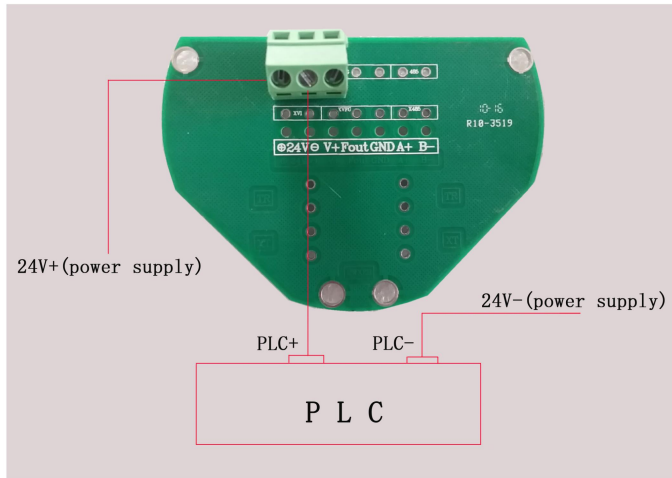

Fourth, the user menu operation

(A), the work screen

After the power is turned on, self-test instrument first, after the completion of the work into the main screen 1 display state.

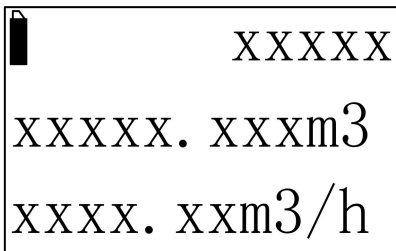

Chart 1 TB2 / 3WE two / three-wire interface work screen 1

First line: high cumulative amount; fixed five-bit integer number is displayed. No full-time five shows "0"

Second row: the cumulative amount of low, after five integer three decimal places, non-time instantaneous flow units and some units of the same.

Third row: instantaneous flow; press 5 or 6 decimal integer and automatically keep two or one, the traffic unit is set by the menu.

TBE3W three-wire for the upper left corner of the battery level indicator, when using battery power meter, the battery power; TBE2W no such display.

Press between the "<" key or the "+" alive work and work screen 2 screen switching

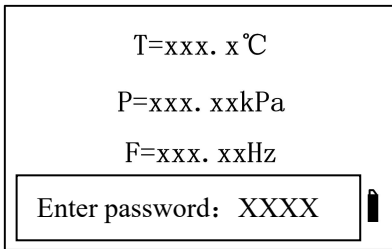

Chart 2 TB3WE work screen 2 interface

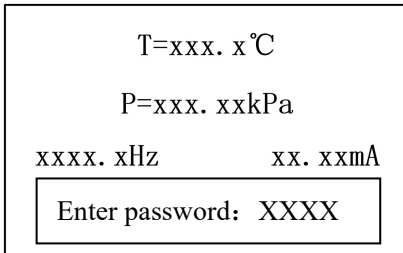

Chart 3 TB2WE work screen 2 interface

First line: temperature setting; used to calculate the related temperature compensation. Display $T \equiv 999.9 \text{ } ^\circ\text{C}$. Reserved a decimal display.

The second line: pressure setting; used to calculate the relevant pressure compensation. Display $P \equiv 99999.99\text{kPa}$, 2 decimal places.

Third line: For TB3WE meter frequency value; TB2WE instrument left is the frequency value, the right end of the output current.

Fourth row: Enter the password setting state.

Press "<" key (long press "<" about 1.2 seconds to confirm, will not be described below) to enter the password initial state.

Press "+" key (long press "+" about 1.2 seconds to exit, will not be described below) to cancel the input state, return to the screen two screen displays.

Press the "+" key in the input state, the cycle to change the value at the cursor position. Press "<" moves the current cursor position input;

Enter state long press "<" key, inspection password. Then enter the menu correctly, incorrectly, it returns to the initial state input.

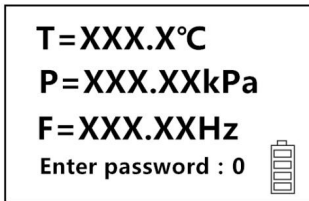

Chart 4 password input interface

(B) the user parameter settings

1, instructions

Press "+" key to exit the input state.

Press "<" key to confirm the save.

Press the "+" key to change the value or cycle symbol at the cursor position.

Press "<" key to move the cursor to the right input of the current one.

Enter up to eight input data (including sign, decimal point).

2, menu operation:

In the Browse menu, press "+" to turn down key; press "<" key to turn on; press "<" key to enter sub menu. Press "+" key to return to work 2 screen interface.

In the sub-menu, press the "+" key to exit; press "<" key to enter the modification mode. In states such as improved modify option, press the "+" key down to select; press "<" select up, press "<" key to confirm. Case input type modified, according to the input operation.

Note: When the parameter is set, the display long press "<" key to confirm before deposit, otherwise it is set invalid

Table 1 User Preferences menu (password 2010)

Submenu Reference	Menu Display	significance	Select an item or range of values
1	Flow unit selection	Flow unit selection(Default 0)	0: m ³ /h 1: m ³ /m 2: l/h 3: l/m4: t/h 5: t/m 6: kg/h 7: kg/m
2	Algorithm Selection	Algorithm Selection (Default 0)	00: Conventional volume flow 01: Conventional mass flow 02: Conventional gas volume flow 03: Conventional gas mass flow
3	Flow	Flow	Set the meter factor, unit: P/m ³

	Coefficient	Coefficient (Default 3600)	
4	Full-scale output flow	Full-scale output flow (Default 1000)	When the meter output 4 ~ 20mA analog signal must be set to the value 0 and can not be consistent, units and flow units
5	Density setting	Density setting (Default 1.0)	When the algorithm selection is set for mass flow (01, 03), you must set this unit is: kg/m ³
6	Temperature settings	Temperature settings (Default 0.0)	Set temperature calculation value when selecting 02, 03 algorithm, this must be set. Degrees Celsius
7	Absolute pressure settings	A gas absolute pressure (Default 101.325)	A gas absolute pressure calculation value when selecting 02, 03, when the algorithm, this must be set. Unit is: kPa (Note: The vacuum will result in flow of 0.0 to 0)
8	The lower limit cut traffic	Setting pulse input percentage removalDefault	Press% full scale flow cut Value between 0 and 100, (When using this type of current and pulse should be properly set

		ult (1%)	range)
9	485 Address	Setting RS485 serial communication (Default 1)	To be set only when the meter performed RS485 communication TB3WE type this, and can not be the same with the other devices in the same system, the range 0 to 255
10	Damping time	Set display output Damping time (Default 4s)	Let the current output and display damping time, output current and to avoid displaying too much with the flow rate fluctuations Range of 2~32
11	The cumulative amount cleared	The cumulative amount cleared	To clear the type of measurement, select YES and press the "E" button

Instrument panel Operating Instructions

Submenu number	Menu Display	Meaning	Select the item or Value range
1	Flow unit selection	Flow unit selection (Default 0)	0: m ³ /h 1: m ³ /h 2: L/h 3:L/m 4:+/h 5:+/h 6:kg/h 7:kg/m
2	Algorithm Selection	Algorithm Selection (Default 0)	00: Conventional volume flow, 01: Conventional mass flow, 02: Conventional gas volume

			flow, 03: Conventional gas mass flow
3	Flow Coefficient	Flow Coefficient (Default 3600)	Set the meter factor, Units:P/m ³
4	Full Scale Output flow	Full Scale Output flow (Default 1000)	When the instrument output4-20MA Analog signals The value must be set, Not to 0 Units and consistent flow units
5	Density setting	Density setting (Default 1.0)	When the algorithm to select the mass flow (01、03), This must be set, Units:KG/m ³
6	Temperature settings	Temperature settings (Default 0.0)	Set the temperature value, Choose 02、03 Algorithm, This must be set , Units: °C
7	Absolute pressure settings	Setting gas absolute pressure	---
8	The lower cut traffic	Set pulse input percentage removal	When the% value of full-scale removal of traffic 0-100 , Use this Current Mode and Pulse type Range should be set correctly

9	485 Address	Set RS485 serial communication	Scope: 0-255
10	Damping time	Setting the display output damping time (Default 4S)	Set current output and display damping time, To avoid the output current with the flow fluctuations and display the range: 2-32
11	Clear the total flow	Clear the total flow	Clear the total flow Choose “YES”, Press “E”

V:CHECK

Instruments of production shall be adjusted on the instrument have a deeper understanding of the professionals in the corresponding precision calibration equipment conditions. In 2-wire calibration range should be at least > 20mA, accuracy of better than 0.1% of the meter.

Production adjustment and some advanced settings are carried out in a production setting state, without the appropriate equipment and sufficient expertise, improper calibration will cause the meter does not work properly. After you verify the password, you can enter a production setting state, depending on the instrument type, set the appropriate instrument parameters.

Before opening the cover, followed by the definition in Table 2 to select the desired setting parameter menu, enter

the production calibration menu

Production calibration menu list (password 2011)

Refer ence subme nu	Menu Displa y	significance	Remarks
1	Init DATA	The setting data is initialized to the default value, usually disabled	To initialize the user data, select YES and press the "E" button
2	485 Baud	485 baud rate setting	00: 4800bps 01: 9600bps default : 4800
3	4mA	Check the output current is 4mA parameters	After pressing E Type the output current value of the ammeter test was

4	12mA	Check the output current of 12mA parameter	After pressing E Type the output current value of the ammeter test was
5	20mA	Check the output current of 20mA parameter	After pressing E Type the output current value of the ammeter test was

IV、 Basic Parameters / Technical Specification

1. Technical Specification:

Nominal Diameter(mm) and Connection method	4,6,10,15,20,25,32,40 (tread connection) 15,20,25,32,40 (tread and flange connection) 50,65,80,100,125,150,200 (flange connection)
Accuracy Class	Regular accuracy $\pm 1\%R$, $\pm 0.5\%R$, Highest accuracy $\pm 0.2\% R$
Measurement Range Rate	1:10,1:15,1:20
Instrument material	304 stainless steel; 316L stainless steel; etc.
Medium Temperature (°C)	-20 ~ +100 °C
Ambient Conditions	Temperature: -10~+55°C, Relative Humidity: 5%~90% Atmosphere Pressure:86~106Kpa

Signal Output	Sensor: pulse frequency signal, low level \leq 0.8V high level \geq 8V. Transmitter: current signal 4 ~ 20mA DCtwo wires
Supply Power	Sensor: +12V DC, +24V DC (option) Transducer: +24V DC Scene display type meter: 3.2V Lithium cell
Signal Transmission Line	STVPV 3 \times 0.3 (three wires), 2 \times 0.3 (two wires)
Transmission Distance	\leq 1000m
Signal Line Interface	Internal thread M20 \times 1.5
Explode-proof Class	ExdIIBT6
Protection Class	IP65

2. Measurement range and Working pressure for liquid

Nominal Diameter (mm)	Regular Flow rate (m ³ /h)	Expanding flow rate (m ³ /h)	Regular tolerance pressure(Mpa)	Special tolerance pressure(Mpa) (flange connection)
DN4	0.04—0.25	0.04—0.4	6.3	12, 16, 25
DN6	0.1—0.6	0.06—0.6	6.3	12, 16, 25
DN10	0.2—1.2	0.15—1.5	6.3	12, 16, 25
DN15	0.6—6	0.4—8	6.3,	4.0, 6.3, 12, 16, 25

DN20	0.8—8	0.45—9	6.3,	4.0, 6.3, 12, 16, 25
DN25	1—10	0.5—10	6.3,	4.0, 6.3, 12, 16, 25
DN32	1.5—15	0.8—15	6.3,	4.0, 6.3, 12, 16, 25
DN40	2—20	1—20	6.3, 2.	4.0, 6.3, 12, 16, 25
DN50	4—40	2—40	2.5	4.0, 6.3, 12, 16, 25
DN65	7—70	4—70	2.5	4.0, 6.3, 12, 16, 25
DN80	10—100	5—100	2.5	4.0, 6.3, 12, 16, 25
DN100	20—200	10—200	2.5	4.0, 6.3, 12, 16, 25
DN125	25—250	13—250	1.6	2.5, 4.0, 6.3, 12, 16
DN150	30—300	15—300	1.6	2.5, 4.0, 6.3, 12, 16
DN200	80--800	40—800	1.6	2.5, 4.0, 6.3, 12, 16

V、Product Category

1. LW series can be divided into two categories by function:

- Turbine flow sensor / transmitter
- Intelligent integration Turbine Flowmeter

2. Function illustration:

➤ Turbine flow sensor/ transmitter

This kind of products have no scene display function,only produce signals to transmit output to far distance. The flow signals can be divided into pulse or current (4-20ma) signal. This instrument has low price, high assemble, small size, so can be applicable to match second displayer,PLC,DCS

so on computer control system to use.

According to different signal outputs, its can be divided into L-N and L-A types.

✧ **N sensor**

12--24V DC power supply, three wires pulse outputs, high level $\geq 8V$, low level $\leq 0.8V$, signal transmission distance $\leq 1000M$.

✧ **A transmitter**

24V DC power supply, two wires current (4—20mA) signal output, signal transmission distance $\leq 1000M$.

➤ **Intelligent integration turbine flowmeter**

It adopts an advanced super-low power consumption single-chip microprocessor technology to make up of new intelligent flowmeter with turbine flow sensor and accumulative calculation displayer integration. It has many obvious advantages which are double-row LCD display at the scene, compact structure, direct and clear reading, high reliability, anti-interference from outside power, anti-thunder attack, and low cost, etc.

It has the instrument factors' three points rectified, non-linear intelligently compensated, and revision at the scene.

High clear LCD display simultaneously shows both instant flow rate (four valid figures) and accumulative flow rate (eight valid figures, and accumulative flow rate (eight valid figures with reset). All valid data can be kept for ten years.

This kind of turbine flowmeters all are explosion-proof

products, and the explosion-proof class is ExdIIB6.

This type of turbine flowmeters can be divided into type LW—B and LW—C in terms of supply power and the remote signal transmitting methods.

LW—B type: supply power 3.2V10AH(Lithium battery) can continuously run more than four years, but no signal output.

LW—C type: supply power 24V DC outside, output normal two wires current signal (4-20 m A) , and can add RS485 or HART communication according to different scene deman

Note: DN15—DN40 need thread connection regularly, but can be made into flange connection through adding the “FL” to the nominal diameter at its end.

VII、 Installation Size

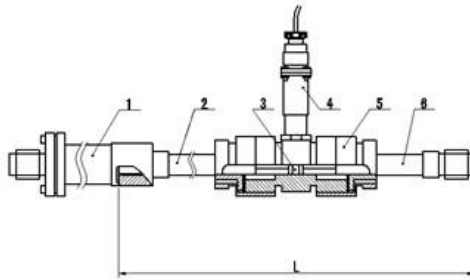

DN 4~10 Sensor Structure & Installation Diagram

- 1.Strainer 2.Before Straight Pipe 3.Impeller 4. Preamplifier
5.Body 6. Back Straight Pipe

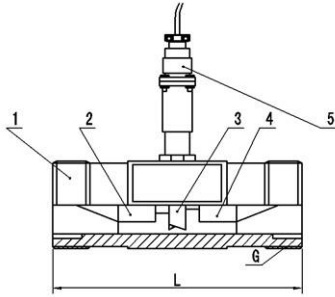

DN15~40 Sensor Structure & Installation Diagram

1. Body 2. Former Guide Part 3. Impeller 4. Back Guide Part
5. Preamplifier

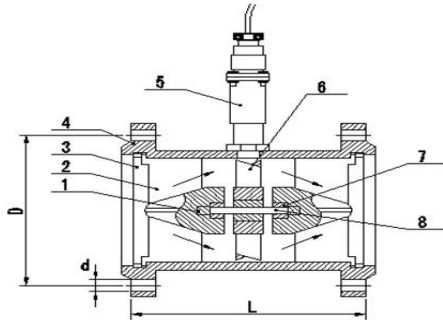

DN50~200 Sensor Structure & Installation Diagram

1. Ball Bearing 2. Former Guide Part 3. O ring 4. Body 5. Preamplifier
6. Impeller 7. Bearing 8. Shaft

VIII、 Cautions in Installation

(1) The installation site:

Sensor should be installed in the sites where is convenient to maintain, have no vibration of pipe, no strong electromagnetic interference, and hot radiation influence. The typical pipe installation system of turbine flowmeter is following as the picture. The each part of configuration can be chosen in view of the objects measured ,which needn't all. It is sensitive for turbine flowmeter to velocity aberrance and rotating flow, so entering sensor should be the pipe flow developed enough and match the necessary straight pipe or rectifier. If upstream side components of flow resistance are variables, the pipeline length upstream generally is not less than 20D and the pipeline length downstream is not less than 5D. If the installation space does not satisfy these demands, the flow rectifier may be installed between the component of flow resistance and sensor. The sensor should be installed outside where avoids the direct sunshine and rain.

(2) The installation demands on connection with pipes:

The horizontally installed sensor demands the pipeline inclination shouldn't be visible (generally within 5°), and the vertically installed one should be same as it. The site needed to run continuously should install the by-pass pipe and reliable cut-off valve. It must be assured that the by-pass pipe has no leakage when measuring.

Location of sensor in a new pipeline is replaced into a short pipe first. After the pipeline inside has been cleared , the short pipe can be changed back into sensor formally. For this step always has

been neglected, the sensor may often be damaged during clearing pipeline.

If the measured fluid includes impurity , the filter should be installed before sensor of upstream side. To continuous flow liquid should install two sets of filters which clear impurity in turn, or choose auto clearing type filer. If the air mixes in the liquid, the eliminator should be installed in the upstream side. The mouth of filter or eliminator must be led to safe site.

If the location of sensor is at the lower point of the pipeline, the drain valve should be fixed after the sensor to discharge the impurity regularly in order to prevent from dwelling deposit. If the measured liquid is easy to be aerified , the exit pressure of sensor should be more than P_{min} in order to prevent from air pockets that may damage the accuracy and live time.

$$P_{min}=2 \Delta P+1.25P_v \quad Pa$$

P_{min} : The lowest pressure, Pa;

ΔP : the pressure loss while the sensor flow rate is the biggest Pa;

P_v : the saturation vapour pressure when the use temperature arrives at the highest point Pa.

Flow control valve should be fixed in the sensor's downstream ,and

the cut-off valve at the upstream side all should be opened, whose valves may not produce vibracation and leakage toward outside.

To

the flow range that might make the reversed flow should prevent

the fluid's reversed flow with fixing the check valve. Both sensor and pipeline should be concentric. The sealed washer is not allowed to have it protruded into the pipeline. The liquid sensor should not be fixed at the top of the horizontal pipeline lest the air converging into the pipe stops in the sensor not to be expelled so as to effect the measurement.

The sensor's front and back pipe sections should be supported firmly so as not to produce vibration. If the fluid is easy to condense, the measurement of keeping temperature should be taken in the sensor and its front and back sections of pipeline.

X、 Adjustment and Application

LW-N basic type turbine flow meter:

This sensor has been calibrated and adjusted before sales, so needn't examination.

The sensor combines with displayer: in the first place, checking the output feature(the pulse frequent range,level,wide etc.) which should match the entry feature of displayer. The displayer parameters must set in terms of sensor factors. The sensor power , wire, and resistance must match each other as well.. In addition, the

sensor's prepositional amplifier must be considered to prevent from electromagnetic interference, for instance, to take action of rain proof.

LW-A turbine flow transmitter:

This transmitter should be set the flow rate output zero point and the full range value well according to the customer demand when purchasing.

When the flowmeter works on and the flow rate output zero point should be adjust on site, the operation method is doing as the follows:

Close the valves of flowmeter pipe, confirm there is not flow rate in pipe; put on the power, the series-connected current meter can monitor the flowmeter's output current; slightly adjust the W502 potentiometer on the circuit board to come the output current back to 4m A.

Note: the flowmeter's full range value couldn't be adjusted on site after it works; If need, please return it to factory to complete that in the standard installation according to your need.

XI、 Cautions in Using

- (1) The switch order putting into running
 - ※ The sensor that have not the branch pipe should slightly open up the half upstream valve, then the downstream valve. When running for a while through a small rate(about ten minutes), open the whole upstream valve and the downstream valve to the normal flowrate.
 - ※ The sensor with branch should first open the branch pipe valve, the half upstream valve, the downstream valve, close the branch valve to small flowrate, and running for a while. Then open the whole upstream valve, close the whole branch valve(be assure of no leak) , finally adjust the downstream valve to the needed flowrate.
- (2) The low and high temperature fluid starts up

When low temperature fluid flows through the pipe, first the water should be expelled, then running for fifteen minutes with a minimum flow, and gradually rise to the normal flow. When stop flowing , also should gradually reduce to approaching pipe temperature and ambient temperature.

The high temperature fluid's running is similar to this low one.
- (3) Other notes:
 - 1) Opening and closing the valve should be slow. If

adopted the auto control switch, it is best to use “two open, two close” way to prevent the fluid against vane wheel to damage it.

2) Check the sensor’s downstream pressure to adopt measures to prevent cavitation.

3) For the sensor factors could appear to change should regularly calibrate away from pipe line. If the flow is not within the allowed range , sensor should be change .

4) Cleaning the pipe needs confirm to the standards of used flow direction,value,presure,and temperature etc.,otherwise can make the accuracy fall,even damage.

5) Strengthen the check for sensor in order to assurance of long time normal working. As finding the unnormal , the measure should be taken. For instance, hearing the unnormal voice as monitoring the vane wheel rotation

XII、 Problem and Solution

problem	Possible reason	solution
No showing or no total adding when liquid normally flows.	Check: 1)open circuit、 loose contact (wire power wire\fuse\coil\PCB) 2)the vane wheel has no rotation	1)find the problem point with electrical meter or replace this circuit board with spare one. 2)clean or replace vane wheel , and assure no rubbing with its neighboring parts.
The flow showing is gradually falling.	1) filter blocks up 2) valve in pipe is loose to the core 3) vane wheel has impurity	1) clean up the filter 2) repair or replace the valve 3) clean the sensor, then need 4) to calibrate again

<p>Its screen has still flow showing when liquid has no flow</p>	<ol style="list-style-type: none"> 1) the cable has no good ground wire with the outer interference; 2) the pipe with vibration to produce error signal 3) the cutoff valve has leakage with leaking flow 4) internal circuit or component of displayer is damaged to produce interference 	<ol style="list-style-type: none"> 1) repair or replace to have a good ground wire; 2) strengthen the pipe line, or install bracket to prevent from vibration; 3) maintain or replace valve 4) gradually check and clear up the interference source. 5)
<p>The displaying value has obvious difference with experience estimation one</p>	<ol style="list-style-type: none"> 1) The sensor's internal tunnel wrong; 2) Sensor's interior appears cavitation; 3) The flow inside pipe causes problems 4) The displayer interior wrong 5) The effect of permanent magnet material is weaker and weaker 6) The real flow is not within its normal range 	<ol style="list-style-type: none"> 1)-4) need first find cause so that use the correct methods; 5)replace the magnet material 6)choose the proper sensor

XIII、Transportation and Storage

The sensor should be put in the solid wooden box (small diameters can be put in carton) and cannot be free to wobble in the box. When carrying, it must be care to put down, and refuse to load or unload crustily.

The location of reservation should be confirmed to the conditions

as the following:

1. avoid rain and humidity;
2. avoid mechanical vibration and strike ;
3. temperature range:-20℃---+55℃ ;
4. relative humidity: not more than 80%;
5. ambient environment does not include corrosive gas.

XIV、Cautions in unpacking

When opening box, files and accessory should be complete. The files in the box include a user manual, a piece of test certificate, and a piece of packing list. The sensor should be observed whether it happens damage during transportation so that dealing with it well. Users must protect the certificate from loss otherwise the instrument factors cannot be set.

XV、Necessary knowledge on order

User should notice that when ordering turbine flowmeter , the proper model specification should be chosen according to fluid's nominal diameter, operating pressure, operating temperature, flow range, the fluid category and the surrounding condition. The anti-explosion type sensor should be chosen when having explosion-proof demand and noticing strictly the explosion-proof classes.

When the display instrument is matched by our company, please refer to the related instruction to choose your proper model or use our design of technological engineer for your choosing in terms of your information offering. The cable using in sending signal you want should provide the length and specification.

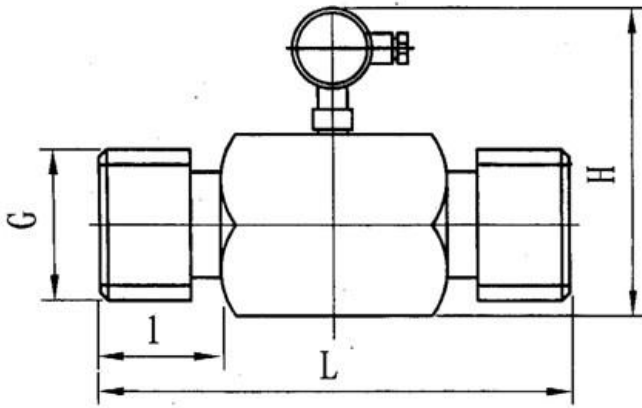

Threaded connection structure

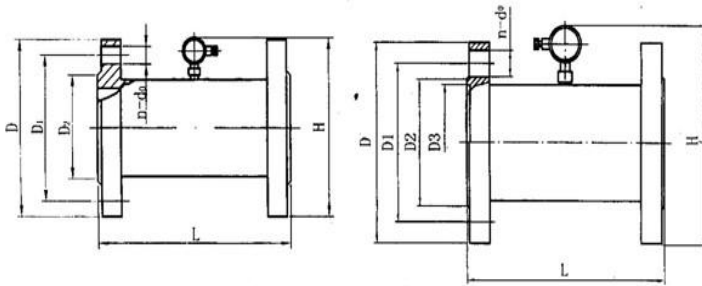

Flange connection structure

Nominal path DN (mm)	Sensor size (mm)	Turbine Flowmeter Instruction37							
		Flange size (mm)						Tube thread size	
		L	H	D	D ₁	D ₂	D ₃	n-do	L1 (mm)
4	225	145							1/2
6	225	145							1/2
10	340	170							1/2
15	75	190	95	65	45		4-14	23	1
20	85	210	105	75	55		4-14	23	1
25	100	230	115	85	65		4-14	30	11/4
32	120	250	140/135	100	78		4-18	30	11/4
40	140	260	150/145	110	85		4-18	35	2
50	150	270	165/160	125	100		4-18		
65	150	290	185/180	145	125		4-18		
80	200	300	200/195	160	135		8-18		

100	220	33 0	220/2 15	18 0	15 5	8-18
125	250	38 0	250/2 45	21 0	18 5	8-18
150	300	39 0	285/2 80	24 0	21 0	8-23
200	360	45 5	340/3 35	29 5	26 5	12-23
250	400	51 0	405	35 5	32 0	12-26/ 25
300	420	56 5	460	41 0	37 5	12-26/ 25
400	560	68 0	580	52 5	48 5	16-30
500	600	79 0	715/7 05	65 0	60 8	20-34