

## Supply Pressure Compensator

Model: ZDC6XP-1XJ/...



- ◆ Size 6
- ◆ Maximum working pressure 315 bar
- ◆ Maximum working flow 26 L/min

### Contents

Function description, sectional drawing	02
Models and specifications	03
Technical parameter	03
Component size	04

### Features

- Sandwich plate type
- Load compensation at the oil port P to A or P to B via built-in shuttle valve
- Two-way version "P"
- Flow control when work with proportional directional valves
- The mounting surface according to the standard DIN24 340 A

Function description, sectional drawing

The ZDC valve is a direct operated supply pressure compensator with two-way design. The valve is mainly composed of the valve body (1), control spool (2), pressure spring (3), two dampers (4), and end cover (5) with integral shuttle valve (6).

As same with all cross sections of throttle valve, the volume flow of proportional throttle valve and directional control valve depends on the differential pressure  $\Delta P$ . The combination of the throttle valve and pressure compensator results the load-compensated electric flow control valve to keep the differential pressure  $\Delta P$  at the throttle valve constant. The pressure difference is determined by the spring of the pressure compensator and depends on the select model when pressure between 8 and 25bar.

When the differential pressure from P1 to A1 or P1 to B1 is less than the spring force, the compression spring (3) holds the control spool (2) from P2 to P1 in the open position. If the differential pressure exceeds the spring force, the control spool (2) moves to the left until the differential pressure is restored.

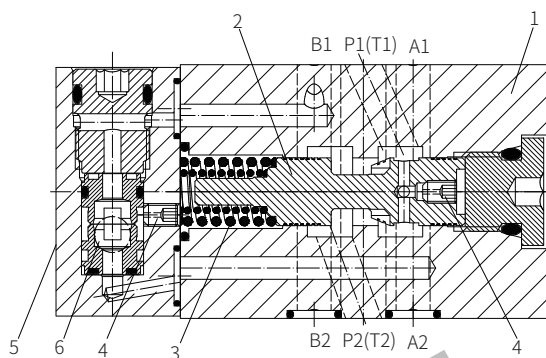

Model ZDC6XP-1XJ/...

Functional symbol:

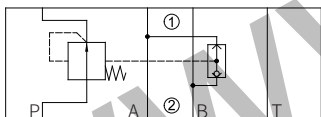

Models and specifications

	ZDC	6	XP	1X	J		*
size 6	=6						more information in text
two-way (reducing function)	=XP						sealing material
10 to 19 series (10 to 19 series installation and connection size unchanged)	=1X						No code= NBR seals V= FKM seals (consult for other seals)
Rekith	=J					14bar=	differential pressure

Technical parameters

Working medium	Mineral oil - for NBR seal and FKM seal	
	Phosphate ester - for FKM seal	
Working medium temperature range °C	-20 to +70	
Viscosity range	mm <sup>2</sup> /s 10 to 800	
Cleanliness of oil	The maximum allowable pollution level of oil is NAS1638 Class7	
Working pressure	bar	
	Oil port A, B, P	315
	Oil port T	210
Maximum flow	L/min 26	

04

