

SS8550

2W Output Amplifier of Portable Radios in Class B Push-pull Operation.

- Complimentary to SS8050
- Collector Current: $I_C=1.5A$
- Collector Power Dissipation: $P_C=2W$ ($T_C=25^\circ C$)



TO-92
1. Emitter 2. Base 3. Collector

PNP Epitaxial Silicon Transistor

Absolute Maximum Ratings $T_a=25^\circ C$ unless otherwise noted

Symbol	Parameter	Ratings	Units
V_{CBO}	Collector-Base Voltage	-40	V
V_{CEO}	Collector-Emitter Voltage	-25	V
V_{EBO}	Emitter-Base Voltage	-6	V
I_C	Collector Current	-1.5	A
P_C	Collector Power Dissipation	1	W
T_J	Junction Temperature	150	$^\circ C$
T_{STG}	Storage Temperature	-65 ~ 150	$^\circ C$

Electrical Characteristics $T_a=25^\circ C$ unless otherwise noted

Symbol	Parameter	Test Condition	Min.	Typ.	Max.	Units
BV_{CBO}	Collector-Base Breakdown Voltage	$I_C = -100\mu A, I_E = 0$	-40			V
BV_{CEO}	Collector-Emitter Breakdown Voltage	$I_C = -2mA, I_B = 0$	-25			V
BV_{EBO}	Emitter-Base Breakdown Voltage	$I_E = -100\mu A, I_C = 0$	-6			V
I_{CBO}	Collector Cut-off Current	$V_{CB} = -35V, I_E = 0$			-100	nA
I_{EBO}	Emitter Cut-off Current	$V_{EB} = -6V, I_C = 0$			-100	nA
h_{FE1}	DC Current Gain	$V_{CE} = -1V, I_C = -5mA$	45	170		
h_{FE2}		$V_{CE} = -1V, I_C = -100mA$	85	160	300	
h_{FE3}		$V_{CE} = -1V, I_C = -800mA$	40	80		
$V_{CE(sat)}$	Collector-Emitter Saturation Voltage	$I_C = -800mA, I_B = -80mA$		-0.28	-0.5	V
$V_{BE(sat)}$	Base-Emitter Saturation Voltage	$I_C = -800mA, I_B = -80mA$		-0.98	-1.2	V
$V_{BE(on)}$	Base-Emitter on Voltage	$V_{CE} = -1V, I_C = -10mA$		-0.66	-1.0	V
C_{ob}	Output Capacitance	$V_{CB} = -10V, I_E = 0$ $f = 1MHz$		15		pF
f_T	Current Gain Bandwidth Product	$V_{CE} = -10V, I_C = -50mA$	100	200		MHz

h_{FE} Classification

Classification	B	C	D
h_{FE2}	85 ~ 160	120 ~ 200	160 ~ 300

Typical Characteristics

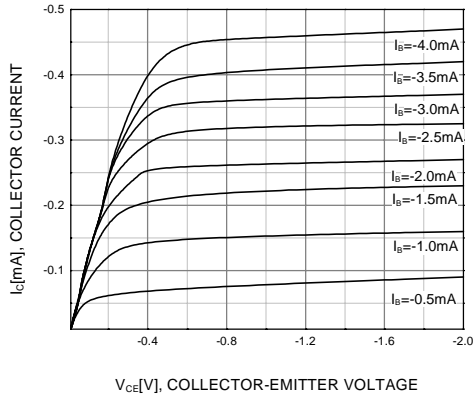

Figure 1. Static Characteristic

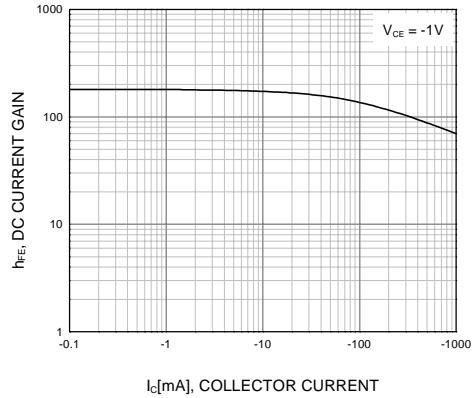

Figure 2. DC current Gain

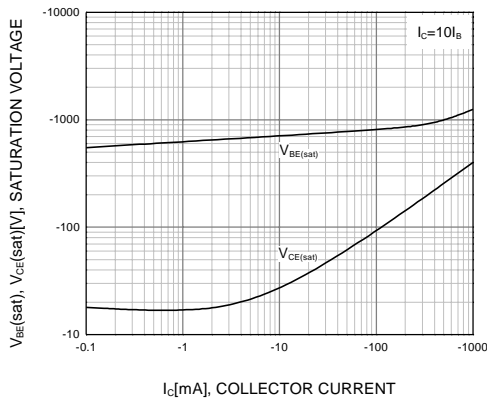

Figure 3. Base-Emitter Saturation Voltage
Collector-Emitter Saturation Voltage

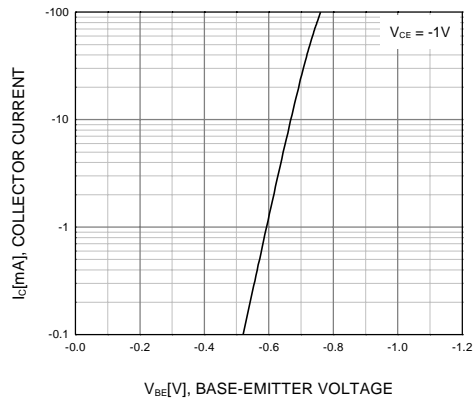

Figure 4. Base-Emitter On Voltage

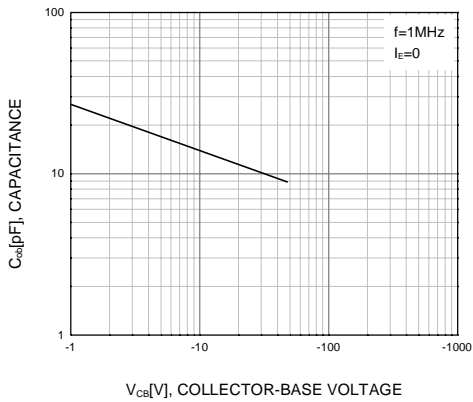

Figure 5. Collector Output Capacitance

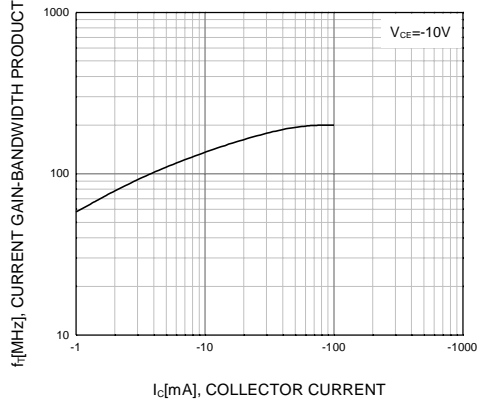
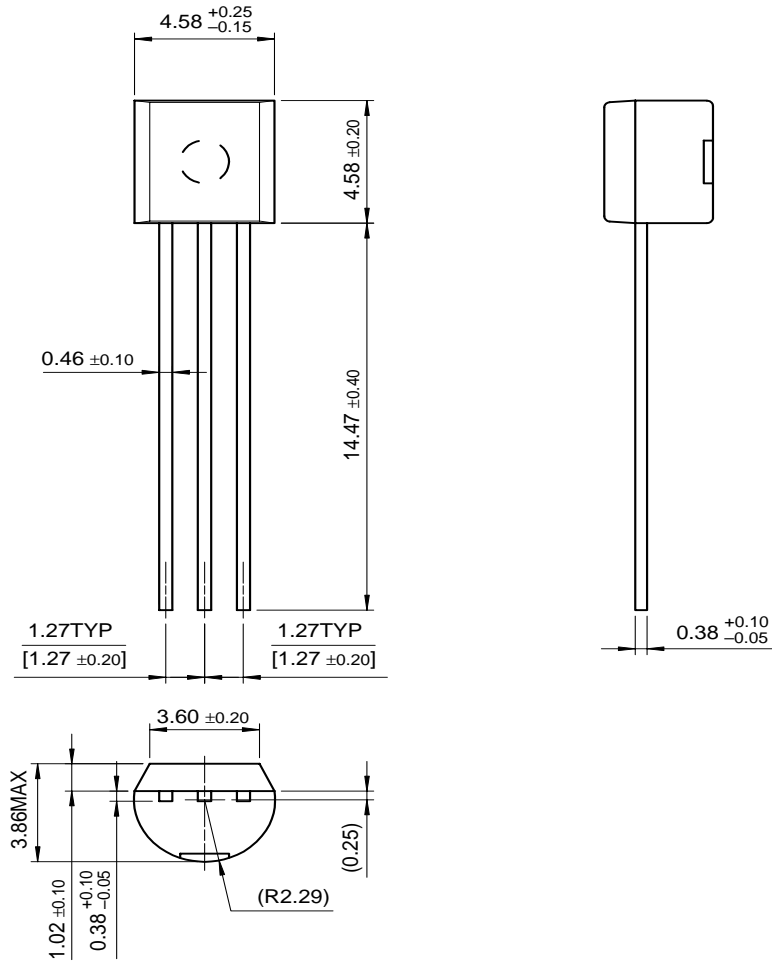

Figure 6. Current Gain Bandwidth Product

Package Dimensions

SS8550

TO-92



Dimensions in Millimeters