

LM383/LM383A 7W Audio Power Amplifier

General Description

The LM383 is a cost effective, high power amplifier suited for automotive applications. High current capability (3.5A) enables the device to drive low impedance loads with low distortion. The LM383 is current limited and thermally protected. High voltage protection is available (LM383A) which enables the amplifier to withstand 40V transients on its supply. The LM383 comes in a 5-pin TO-220 package.

Features

- High peak current capability (3.5A)
- Large output voltage swing
- Externally programmable gain
- Wide supply voltage range (5V–20V)
- Few external parts required
- Low distortion
- High input impedance
- No turn-on transients
- High voltage protection available (LM383A)
- Low noise
- AC short circuit protected

Equivalent Schematic

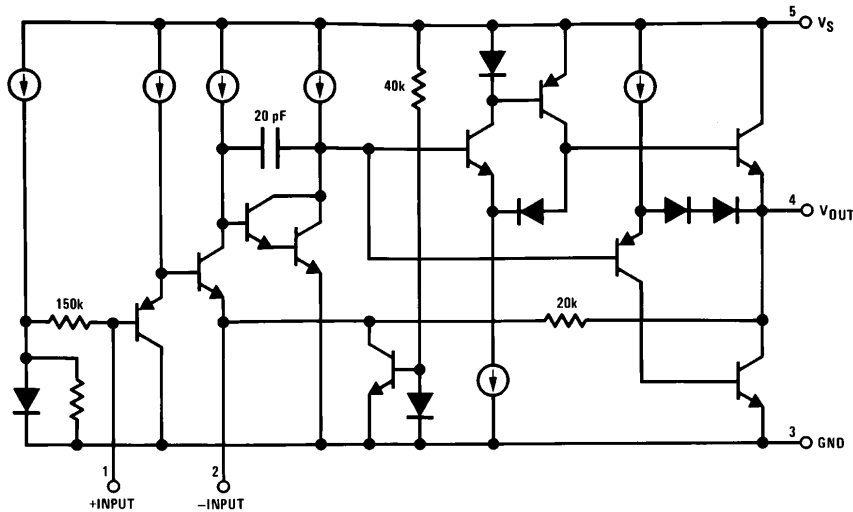

TL/H/7145-1

Connection Diagram

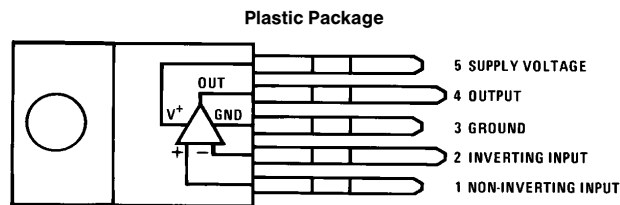

Order Number LM383T or LM383AT
See NS Package Number T05B

TL/H/7145-2

Absolute Maximum Ratings

If Military/Aerospace specified devices are required, please contact the National Semiconductor Sales Office/Distributors for availability and specifications.

Peak Supply Voltage (50 ms)	
LM383A (Note 2)	40V
LM383	25V
Operating Supply Voltage	20V
Output Current	
Repetitive	3.5A
Non-repetitive	4.5A

Input Voltage	±0.5V
Power Dissipation (Note 3)	15W
Operating Temperature	0°C to +70°C
Storage Temperature	-60°C to +150°C
Lead Temperature (Soldering, 10 sec.)	260°C

Electrical Characteristics $V_S = 14.4V$, $T_{TAB} = 25^\circ C$, $A_V = 100$ (40 dB), $R_L = 4\Omega$, unless otherwise specified

Parameter	Conditions	Min	Typ	Max	Units
DC Output Level		6.4	7.2	8	V
Quiescent Supply Current	Excludes Current in Feedback Resistors		45	80	mA
Supply Voltage Range		5		20	V
Input Resistance			150		k Ω
Bandwidth	Gain = 40 dB		30		kHz
Output Power	$V_S = 13.2V$, $f = 1$ kHz		4.7		W
	$R_L = 4\Omega$, THD = 10%		7.2		W
	$R_L = 2\Omega$, THD = 10%		5.1		W
	$V_S = 13.8V$, $f = 1$ kHz		7.8		W
	$R_L = 4\Omega$, THD = 10%		4.8		W
	$R_L = 2\Omega$, THD = 10%		7		W
	$V_S = 14.4V$, $f = 1$ kHz		8.6		W
	$R_L = 4\Omega$, THD = 10%		9.3		W
	$R_L = 2\Omega$, THD = 10%		7		W
	$R_L = 1.6\Omega$, THD = 10%		10.5		W
			11		W
THD	$P_O = 2W$, $R_L = 4\Omega$, $f = 1$ kHz		0.2		%
	$P_O = 4W$, $R_L = 2\Omega$, $f = 1$ kHz		0.2		%
Ripple Rejection	$R_S = 50\Omega$, $f = 100$ Hz	30	40		dB
	$R_S = 50\Omega$, $f = 1$ kHz		44		dB
Input Noise Voltage	$R_S = 0$, 15 kHz Bandwidth		2		μV
Input Noise Current	$R_S = 100$ k Ω , 15 kHz Bandwidth		40		pA

Note 1: A 0.2 μF capacitor in series with a 1 Ω resistor should be placed as close as possible to pins 3 and 4 for stability.

Note 2: The LM383 shuts down above 25V.

Note 3: For operating at elevated temperatures, the device must be derated based on a 150°C maximum junction temperature and a thermal resistance of 4°C/W junction to case.

Typical Performance Characteristics

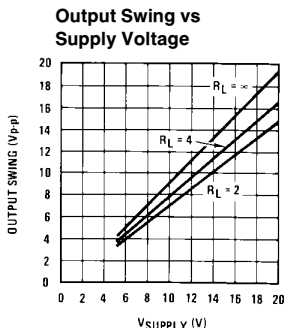
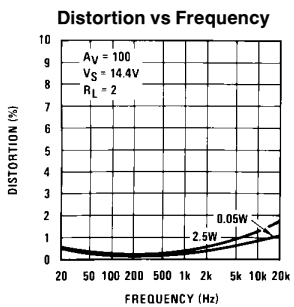
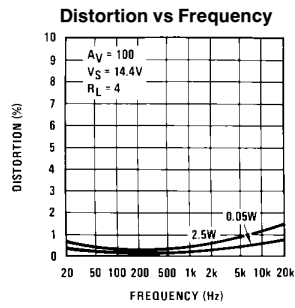
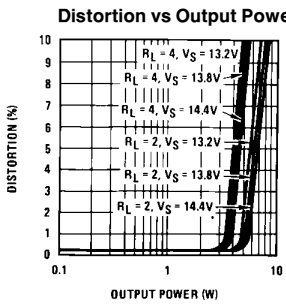
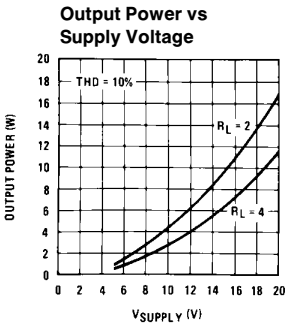
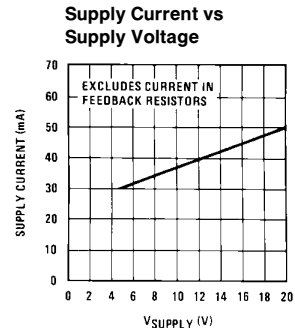
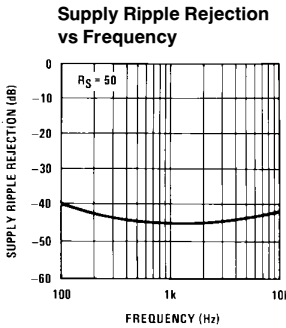
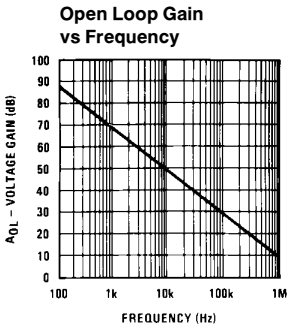
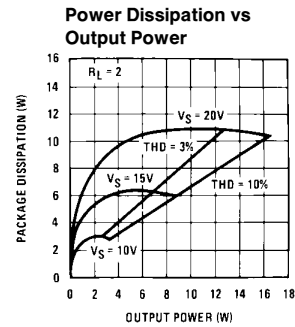
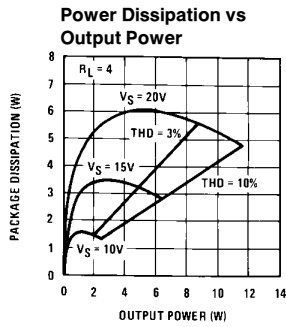
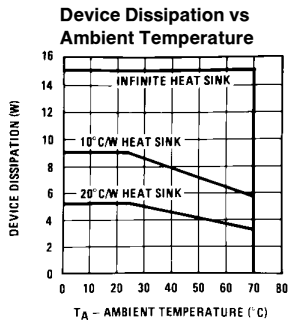

TL/H/7145-4

Typical Applications

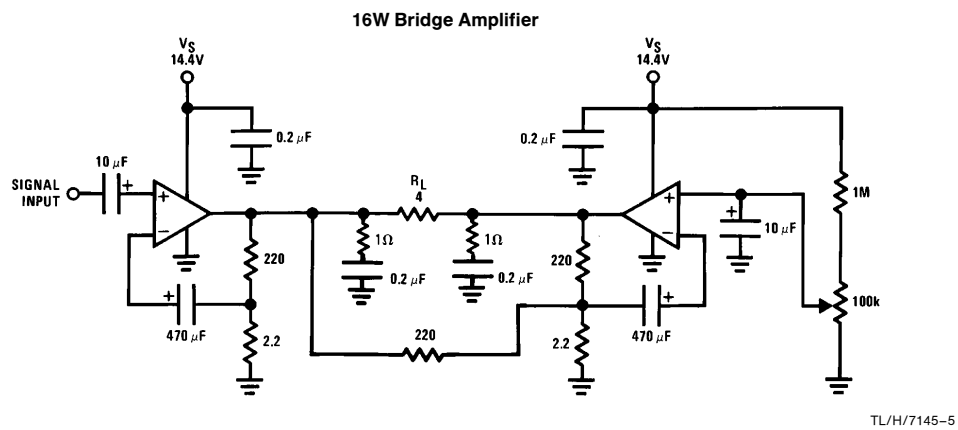
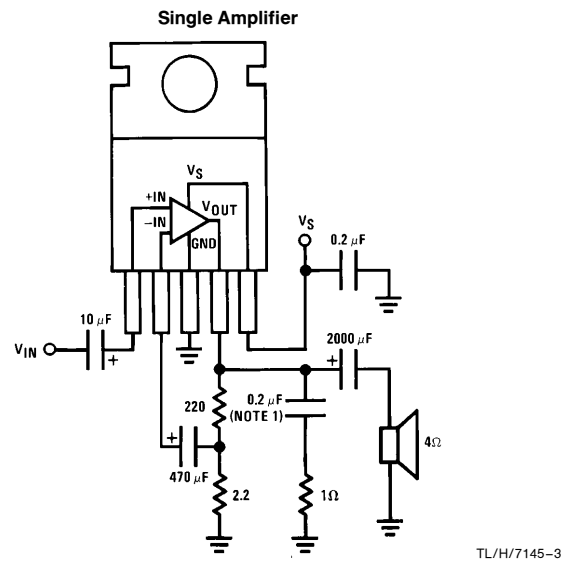

Component Layout

Single Amplifier
 $V_S = 20V$
 $R_L = 4\Omega$

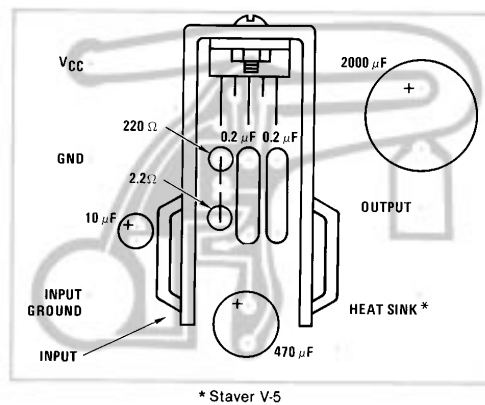

Heatsink from:
 Staver Company
 41 Saxon Ave.
 P.O. Drawer H
 Bay Shore, NY 11706
 Tel: (516) 666-8000

TL/H/7145-6



Physical Dimensions inches (millimeters)

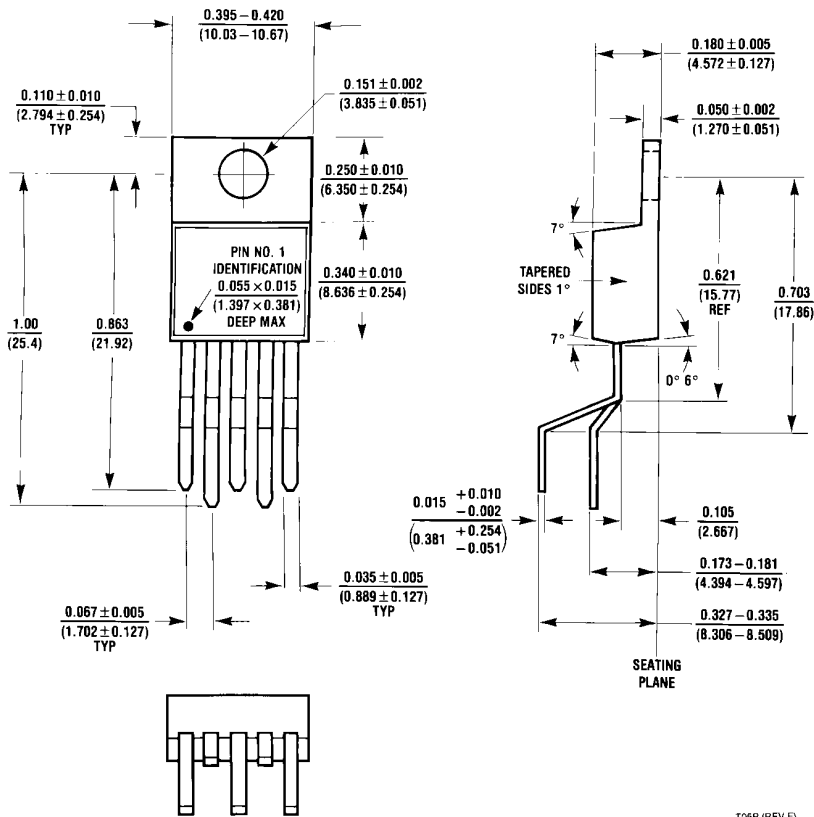

Order Number LM383T or LM383AT
NS Package Number T05B

LIFE SUPPORT POLICY

NATIONAL'S PRODUCTS ARE NOT AUTHORIZED FOR USE AS CRITICAL COMPONENTS IN LIFE SUPPORT DEVICES OR SYSTEMS WITHOUT THE EXPRESS WRITTEN APPROVAL OF THE PRESIDENT OF NATIONAL SEMICONDUCTOR CORPORATION. As used herein:

1. Life support devices or systems are devices or systems which, (a) are intended for surgical implant into the body, or (b) support or sustain life, and whose failure to perform, when properly used in accordance with instructions for use provided in the labeling, can be reasonably expected to result in a significant injury to the user.
2. A critical component is any component of a life support device or system whose failure to perform can be reasonably expected to cause the failure of the life support device or system, or to affect its safety or effectiveness.



National Semiconductor Corporation
1111 West Bardin Road
Arlington, TX 76017
Tel: 1(800) 272-9959
Fax: 1(800) 737-7018

National Semiconductor Europe
Fax: (+49) 0-180-530 85 86
Email: onjwge@tevm2.nsc.com
Deutsch Tel: (+49) 0-180-530 85 85
English Tel: (+49) 0-180-532 78 32
Français Tel: (+49) 0-180-532 93 58
Italiano Tel: (+49) 0-180-534 16 80

National Semiconductor Hong Kong Ltd.
19th Floor, Straight Block,
Ocean Centre, 5 Canton Rd.
Tsimshatsui, Kowloon
Hong Kong
Tel: (852) 2737-1600
Fax: (852) 2736-9960

National Semiconductor Japan Ltd.
Tel: 81-043-299-2309
Fax: 81-043-299-2408

National does not assume any responsibility for use of any circuitry described, no circuit patent licenses are implied and National reserves the right at any time without notice to change said circuitry and specifications.