

一、PV2R 系列高压低噪声叶片泵

PV2R Series Vane Pumps with High Pressure and Lower Noise

产品简介 Products Introduction



PV2R 系列高压低噪声叶片泵是我公司独立研制开发的国产化高性能产品，具有性能先进，结构合理，可靠性好，噪声低，脉动极小，质量稳定的特点。产品精工制造，特别适应高精度低噪声设备的要求，广泛应用于切削机械、塑料机械、皮革机械、锻压机械、工程机械等领域。

PV2R Series vane pumps with high pressure and lower noise are high-performance products, which are developed and domestically produced by our company, featured by advanced performance, reasonable structure, good creditability, lower noise, ultra-low pulse and stable quality and so on. Precisely made, the product can be used in the equipment with high precision and low noise, and is widely used in cutting, plastic, leather, forging and engineering machinery fields, and the like.

型号说明 Model Code

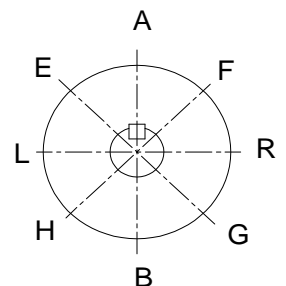
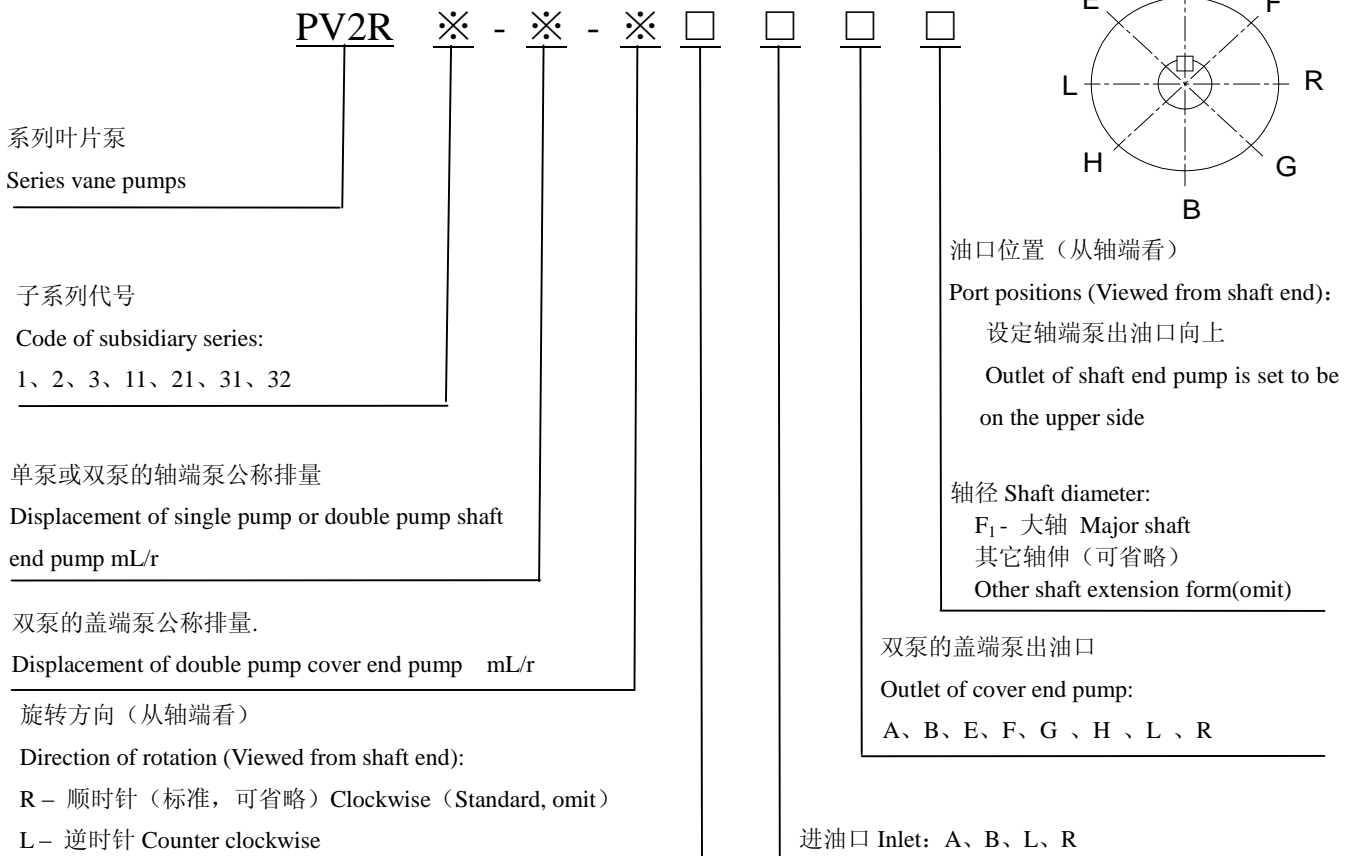

技术规格 Specifications

◆ 单 泵 Single Pump

产品型号 Model	理论排量 Displacement mL/r	最高压力 Max. pressure MPa							允许转速 Speed r/min		驱动 功率 Input power kW	质量 Weight kg
		高压用 特定油 Special oil	抗磨 液压油 Antiwear oil	普通 液压油 Common oil	抗磨型水 乙二醇液 Antiwear water glycol fluid	水乙二 醇液 Water glycol fluid	油包水 乳化液 Water-oil emulsions	磷酸酯液 Phosphate ester fluid	最低 Min.	最高 Max.		
PV2R1-4	4.3	21	17.5	16	16	7	7	16	750	1800 (1200)	2.1	8
PV2R1-6	6.1										3.2	
PV2R1-8	8.5										4.5	
PV2R1-10	10.4										5.4	
PV2R1-12	13										6.1	
PV2R1-14	14.2										6.9	
PV2R1-17	16.8										7.9	
PV2R1-19	19.4										9.6	
PV2R1-23	23.3										10.5	
PV2R1-25	24.4										12.5	
PV2R1-28	28.4	14.0										
PV2R1-31	29.5	16	16							15.5		
PV2R2-17	17.7	21	17.5	14	16	7	7	14	600	1800 (1200)	7.8	16
PV2R2-26	26.6										11.7	
PV2R2-33	32.8										15.5	
PV2R2-41	41.7										18.9	
PV2R2-47	47.9										23.2	
PV2R2-53	55.7										24	
PV2R2-59	58.2										24.9	
PV2R2-65	63.3										29.4	
PV2R2-70	70.3	16	16						1200	31.6	17	
PV2R2-75	78.1			35.7								
PV2R2-85	82.7			37.5								
PV2R3-52	52.9	21	17.5	14	16	7	7	14	600	1800 (1200)	23.2	32
PV2R3-60	64.3										29.4	
PV2R3-66	67.2										34.2	
PV2R3-76	76										37.7	
PV2R3-94	94.2										41.2	
PV2R3-116	115.8										50	
PV2R3-125	127	16	16						1200	55		
PV2R3-136	132.5			57								

高压用特定油、抗磨型水乙二醇液的牌号参见 10 页

Grades of Special oil and Antiwear water glycol fluid, see page twelve.

- 注:**
- 1.公称排量“4”、“6”、“8”泵，压力超过 16MPa 使用时，转速应超过 1450r/min。
 - 2.在高转速下使用大排量单泵及相应的双泵时，应减少吸入口负压。
 3. () 内的值为使用磷酸酯液和含水液压液的值。
 - 4.对于特别要求低噪声的场合，建议工作转速选用 1000r/min。
 - 5.工作液为磷酸酯液时，因需要采用特殊性密封（氟橡胶），订货时请在指定型号前加[F-]。
 - 6.驱动功率是在 P=16MPa、n=1500r/min 的工况下。

- Note:**
1. When pressure of pumps exceeds 16MPa, with displacement of “4” “6” “8”, , speeds should be more than 1450 r/min.
 2. Reduce the negative pressure of the inlet when the Single Pump or double pumps with large displacement at high speed.
 3. The numerical number in bracket is the one using phosphate ester fluid and water containing hydraulic fluid.
 4. Speed at 1000r/min is suggested on occasions with lower noise strictly required.
 5. When the working fluid is phosphate ester fluid, it uses special sealing (FPM), Prefix [F-] to the specified model when ordering.
 6. Input power is available in working conditions of 16 MPa and 1500r/min.

◆双联泵 Double Pumps

泵系列号 Series	轴端泵排量 Displacement of shaft end pump	盖端泵排量 Displacement of cover end pump
PV2R11	4、6、8、10、12、14、17、19、23、25、28、31	4、6、8、10、12、14、17、19、23、25、28、31
PV2R21	17、26、33、41、47、53、59、65、70、75、85	4、6、8、10、12、14、17、19、23、25、28、31
PV2R31	52、60、66、76、94、116、125、136	4、6、8、10、12、14、17、19、23、25、28、31
PV2R32	52、60、66、76、94、116、125、136	17、26、33、41、47、53、59、65、70、75、85

安装联接尺寸 Install Connection Dimensions

◎单 泵 Single Pump

◆ PV2R1

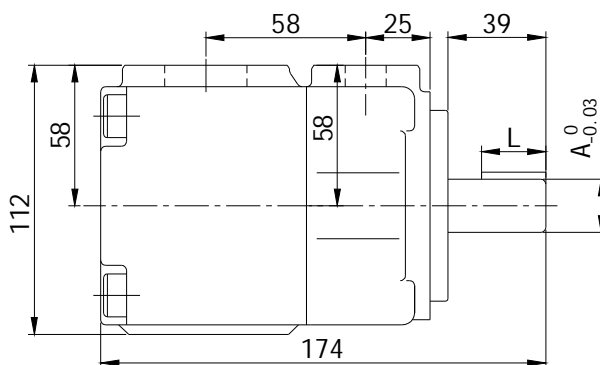
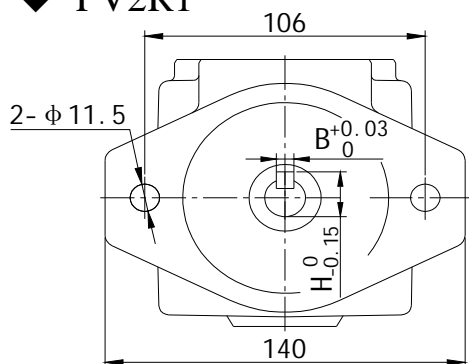

轴伸形式 shaft extension	A	B	H	L
F	φ 15.88	3.97	17.68	25(B型键)
F ₁	φ 19.05	4.75	21.24	28(A型键)

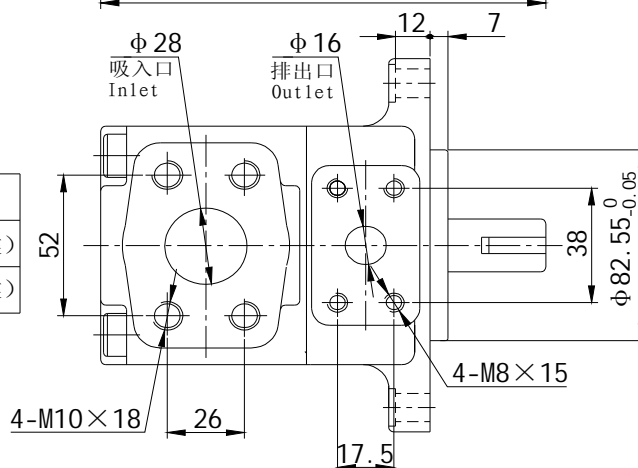

◆ PV2R2

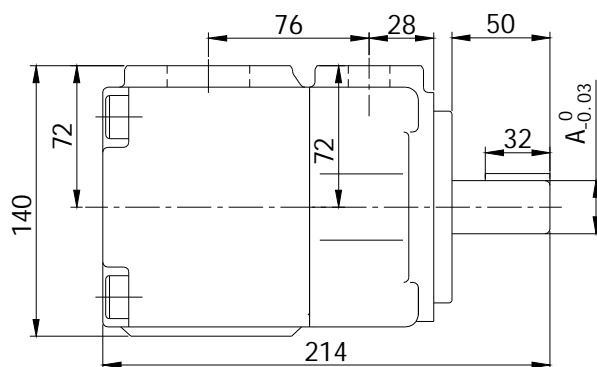
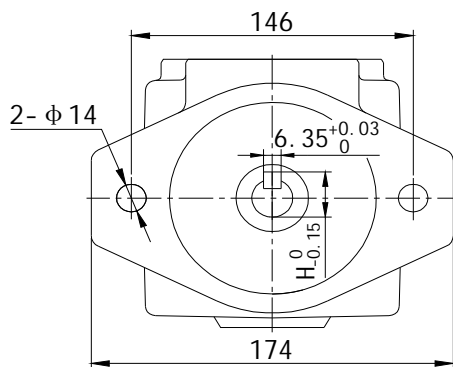

轴伸形式 shaft extension	A	H
F	φ 22.22	25
F ₁	φ 25.4	28.18

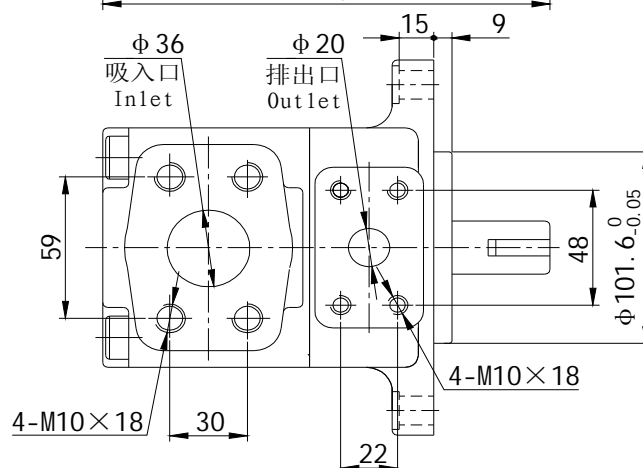

◆ PV2R3

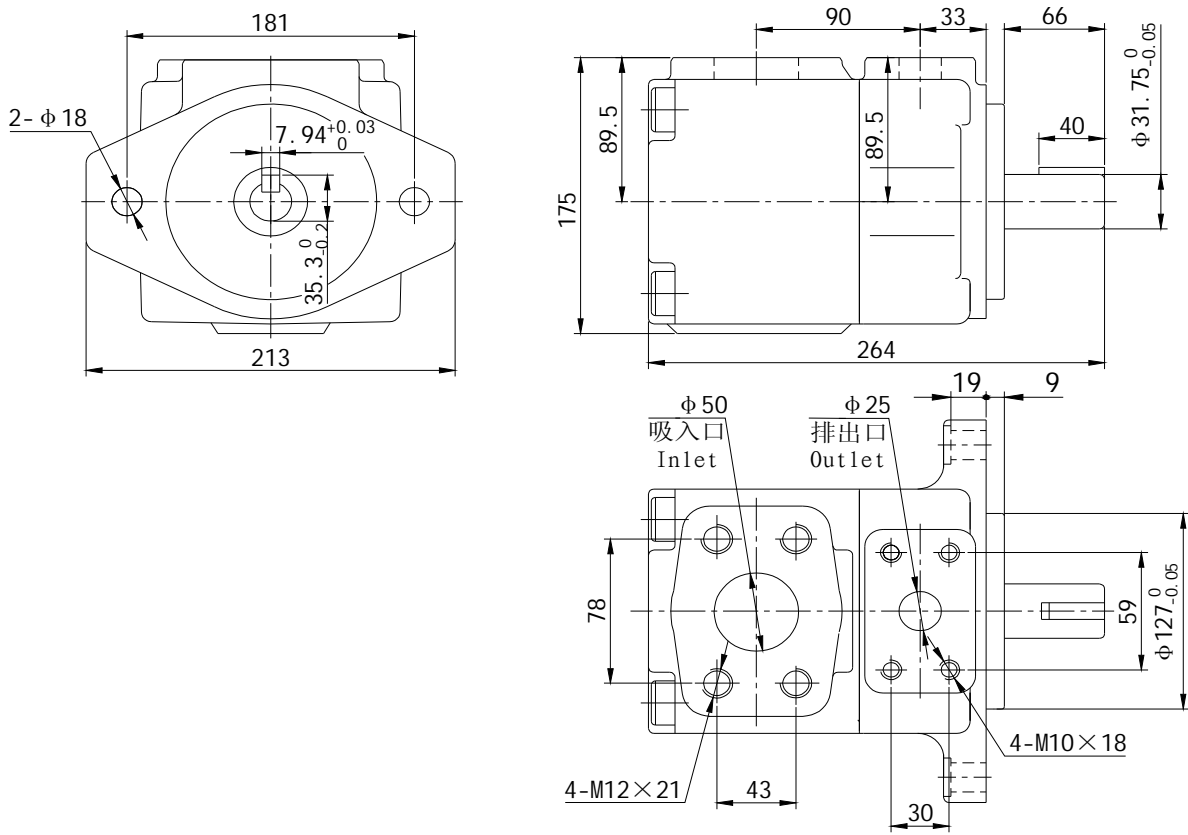

◎双联泵 Double Pumps

◆ PV2R11

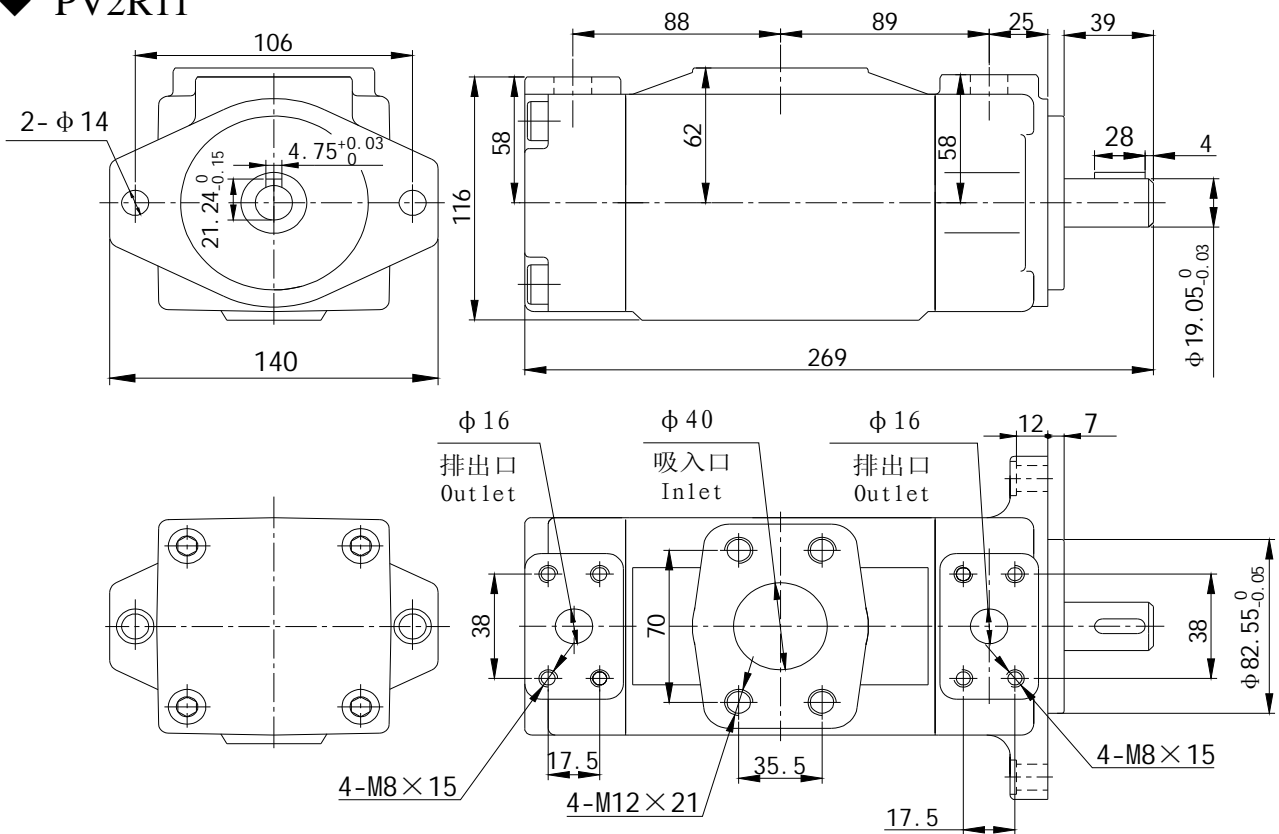

◆ PV2R21

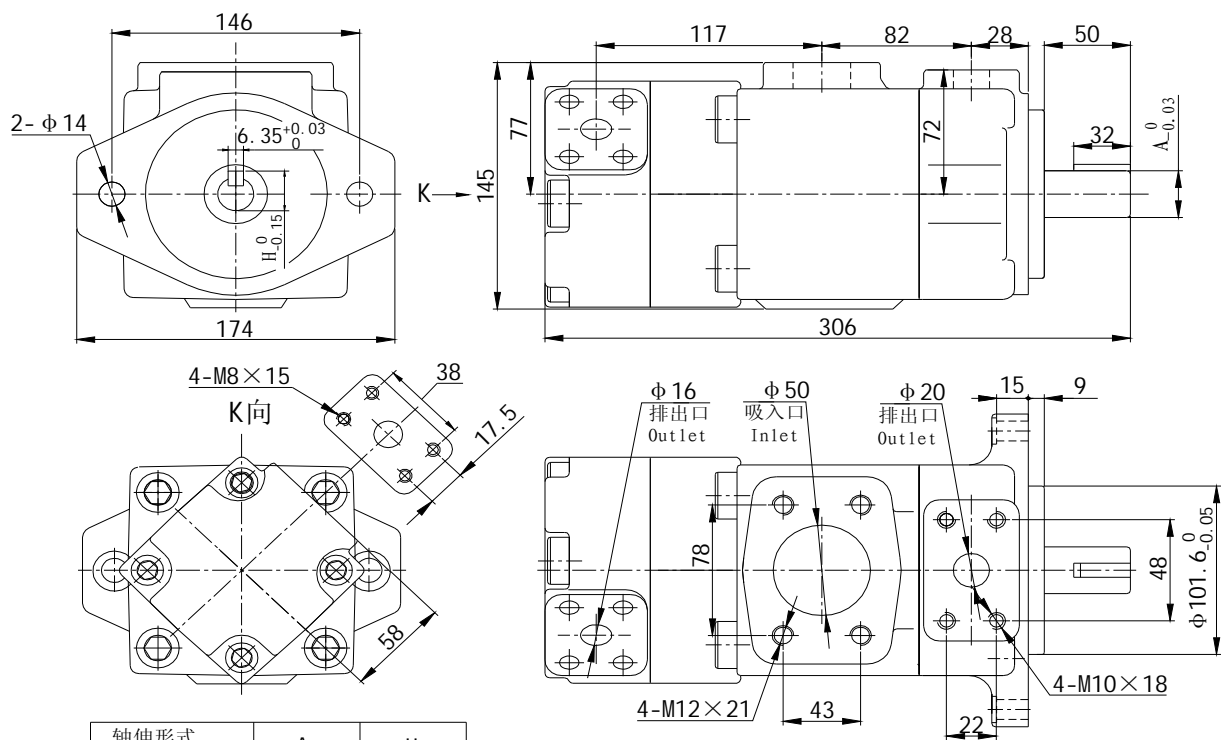

轴伸形式 shaft extension	A	H
F	$\phi 22.22$	25
F ₁	$\phi 25.4$	28.18

◆ PV2R31

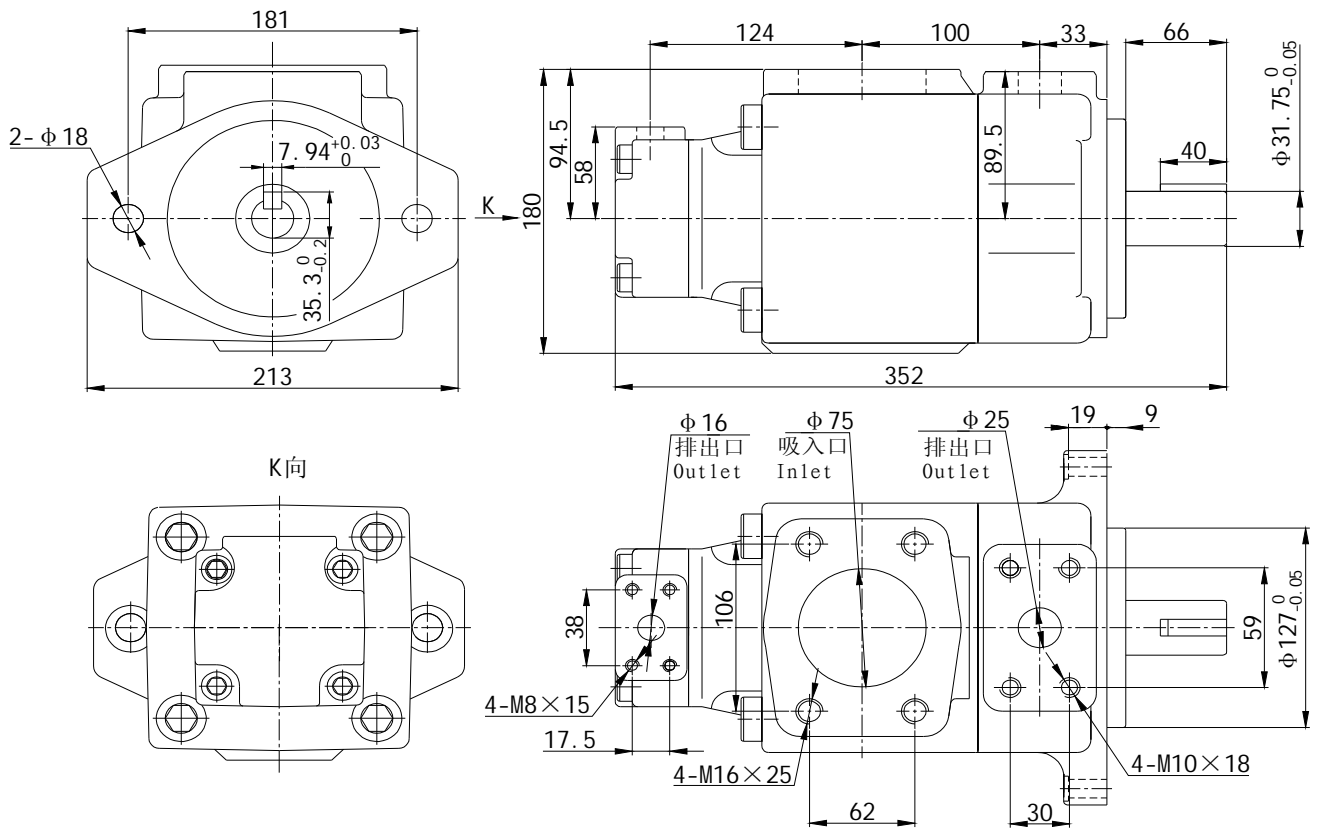

◆ PV2R32

