

## High voltage NPN Power transistor

### 8A, 1500V

**FEATURES**

- Stable performance vs. operating temperature variation
- High ruggedness
- Tight  $h_{FE}$  range at operating collector current
- TO-3P and TO-247AB package which can be installed to the heat sink with one screw

**APPLICATIONS**

- Switching mode power supplies and general purpose
- High frequency inverters

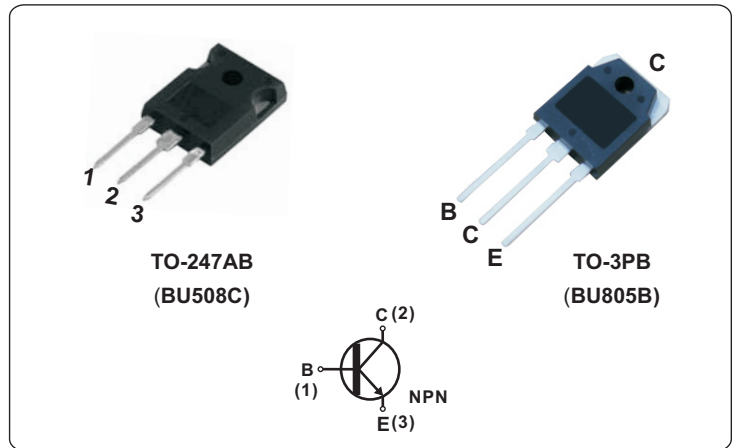

ABSOLUTE MAXIMUM RATINGS ( $T_C = 25^\circ\text{C}$ unless otherwise specified)				
SYMBOL	PARAMETER	TEST CONDITIONS	VALUE	UNIT
$V_{CES}$	Collector to emitter voltage	$V_{BE}=0$	1500	V
$V_{CEO}$	Collector to emitter voltage	$I_B=0$	700	
$V_{EBO}$	Emitter to base voltage	$I_C=0$	9	
$I_C$	Collector current-continuous		8	A
$I_{CM}$	Peak collector current	$t_p < 5 \text{ ms}$	15	
$I_B$	Base Current		4	
$P_D$	Collector power dissipation	$T_C=25^\circ\text{C}$	125	W
$T_J$	Junction temperature		150	$^\circ\text{C}$
$T_{STG}$	Storage temperature		-55 to 150	

THERMAL CHARACTERISTICS ( $T_C = 25^\circ\text{C}$ )			
SYMBOL	PARAMETER	VALUE	UNIT
$R_{th(j-c)}$	Thermal resistance, junction to case	1.0	$^\circ\text{C/W}$

ELECTRICAL CHARACTERISTICS ( $T_C = 25^\circ\text{C}$ unless otherwise specified)						
SYMBOL	PARAMETER	TEST CONDITIONS	Min.	Typ.	Max.	UNIT
$I_{CES}$	Collector cutoff current ( $V_{BE} = 0$ )	$V_{CEO}=1500\text{V}, I_E=0$			0.2	mA
					2	
$I_{EBO}$	Emitter cutoff current	$V_{EBO}=9\text{V}, I_C=0$			1.0	
$V_{CEO}$	Collector to emitter voltage	$I_B=0$	700			V
$V_{CEO(SUS)}^*$	Collector to emitter sustaining voltage	$I_C=100\text{mA}$	700			
$h_{FE}^*$	Forward current transfer ratio (DC current gain)	$I_C=0.1\text{A}, V_{CE}=5\text{V}$	10		30	
		$I_C=4.5\text{A}, V_{CE}=5\text{V}$	5			
$V_{CE(sat)}^*$	Collector to emitter saturation voltage	$I_C=4.5\text{A}, I_B=1.6\text{A}$			1.0	V
$V_{BE(sat)}^*$	Base to emitter saturation voltage	$I_C=4.5\text{A}, I_B=2\text{A}$			1.1	
$t_{stg}$	Storage time	$I_C=4.5\text{A}, I_{B(on)}=0.5\text{A}, V_{BE(off)}=-2.7\text{V}$ $f_h=16\text{KHz}, L_{BB(off)}=4.5\mu\text{H}$		2.5		$\mu\text{S}$
$t_f$	Fall time			0.2		

\*Pulsed: Pulse duration= 300 $\mu\text{s}$ , duty cycle= 1.5%.

**Fig.1 Power derating**

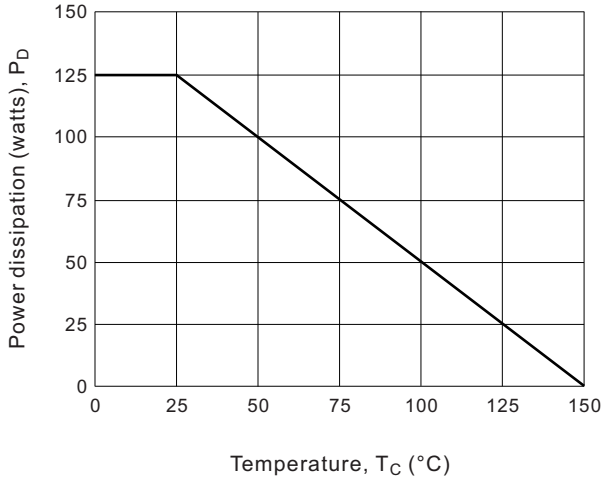

**Fig.2 Collector saturation region**

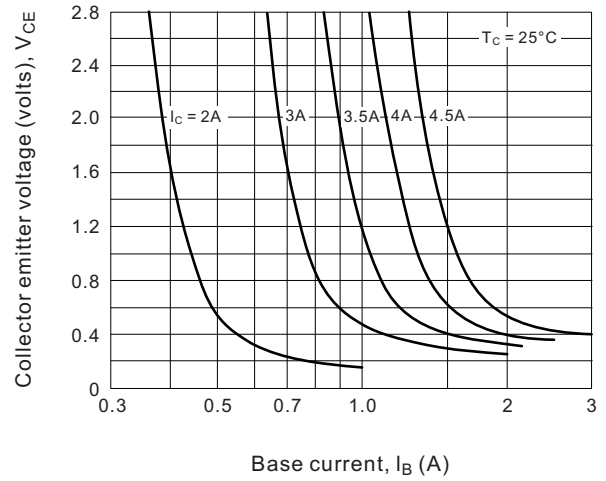

**Fig.3 DC current gain, hFE**

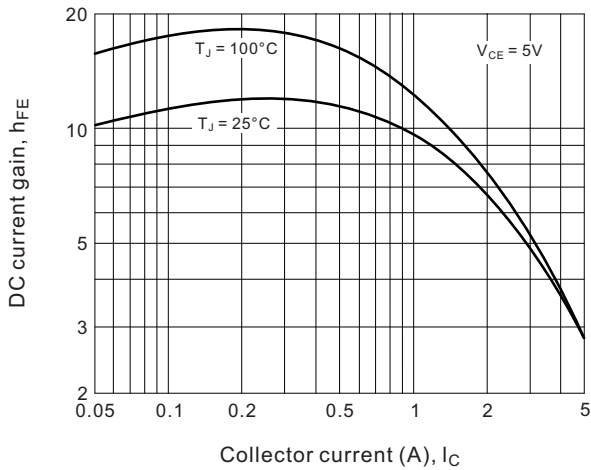

**Fig.4 "ON" voltages**

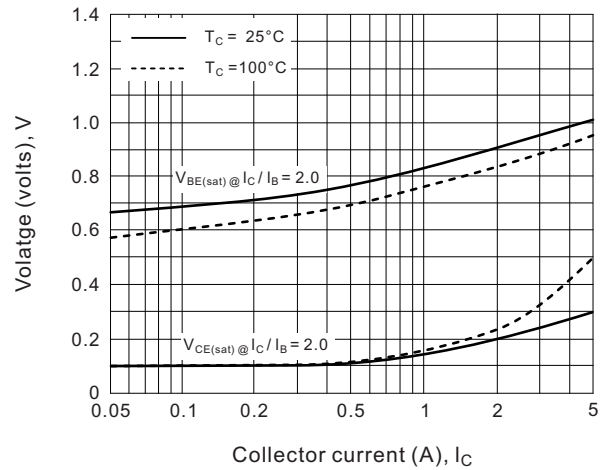

**Fig.5 Switching behavior vs.  $I_{CM}$**

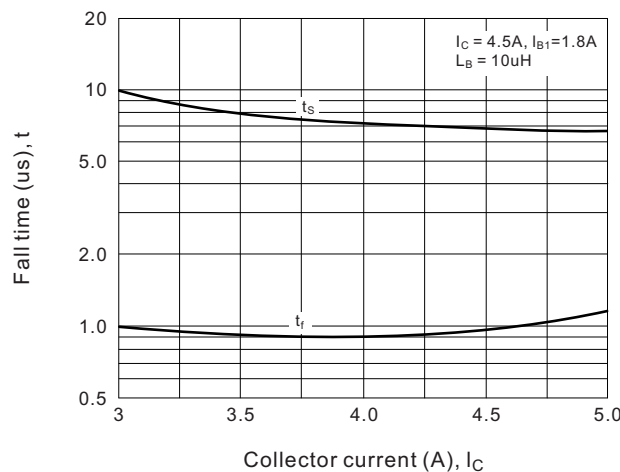

**Fig.6 Forward bias safe operating area**

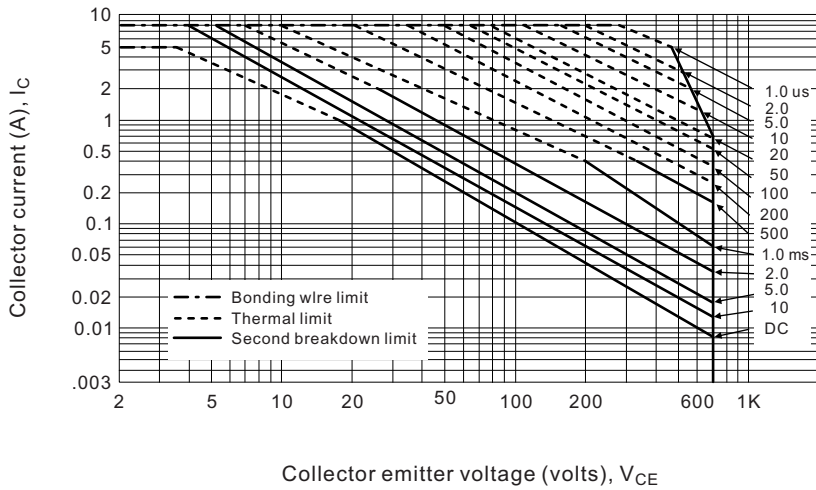

**TO-247AB**

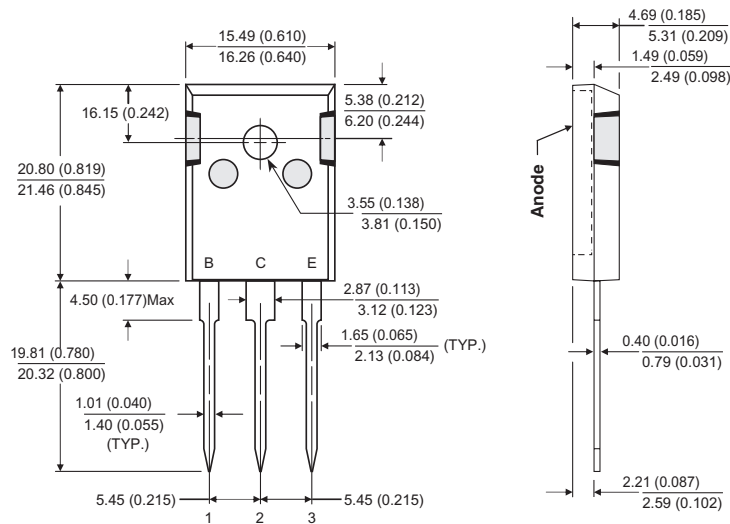

All dimensions in millimeters (inches)

